



CLASS B

OWNER'S MANUAL



For more information on model features and options, documentation, and the electronic version of this owner's manual, please visit the manufacturer's website or scan the QR code found on the decal just outside the front door of the recreational vehicle.



Hello, I'm Ken Walters, President and CEO of Jayco. I'd like to personally welcome you to the Jayco Family.

The Jayco Family of Companies is comprised of four brands - Jayco, Entegra Coach, Open Range RV and Heartland RV. These divisions have been manufacturing RVs for over 50 years on a tradition anchored in three pillars - Quality, Team and Family. If you are a first-time owner, thank you for choosing us. If you're a second, third or tenth owner, we are beyond pleased to have kept you in the family.

Our mission has remained unchanged since 1968 - design and build with innovation and safety at the forefront of all we do, and continue to be a leading manufacturer for both towable and motorized RVs. From the first pop-up camper built on the Bontrager family farm, to the technology-packed lineup we build today, we always strive for better.

Over the next few years, we hope the memories made in your new RV are ones to remember. Thank you for taking us along for the ride and for letting us be a part of your stories.

Sincerely,

Ken Walters
President and CEO of Jayco



Training, How-To and Walk Through Videos

Scan the QR Code to access an extensive video training series for owners of Jayco & Highland Ridge brands of RVs, produced in collaboration with the National RV Training Academy (NRVTA). The series provides an in-depth library of videos to provide new and existing owners with training, reference and how-to material for nearly all of the systems and components you will utilize in your RV.



VIDEO
LIBRARY



If you have passion for travel, love your RV and have an undeniably unique RV lifestyle, apply to become a Jayco Family of Companies' Pathfinder. As true pioneers and pathfinders of the authentic RV lifestyle, you are in the unique position to offer a genuine depiction of the different segments that come together to build an exclusive RV community. Through you, your stories and the compelling content you create, you'll elevate our brands while strengthening your own, increasing followers, inspiring RVers and establishing yourself as leaders and experts in the RV world.

GET SOCIAL WITH US!



PATHFINDER
COMMUNITY



FOLLOW
US



CHANGE OF
OWNERSHIP

ABOUT THIS MANUAL

This manual is a guide to operation of the features, equipment and controls in your recreational vehicle (RV). If you find components vary significantly from what is described, please contact your dealer to ensure you have the correct information. Nothing in this manual creates any warranty, either expressed or implied, nor does it cover every possible detail of equipment, standard or option, installed on or in your RV.

Information, illustrations and specifications in this manual reflect the most current available at the time of publication approval, are subject to change and not intended to indicate actual size.

This Owner's Manual and Customer Information Packet are to be considered permanent components of the RV. Keep them in your RV at all times for personal reference. If the RV is sold, they should remain with the RV for the next owner.

CUSTOMER INFORMATION PACKET

There are components that are excluded from the RV warranty, or are warranted separately by their own individual manufacturer's limited warranty. The Customer Information Packet contains the component manufacturer supplied manuals or information sheets, warranty cards and/or registrations. Consult this information for questions regarding operating, maintenance, servicing instructions and warranty coverage. It is important you complete and mail warranty cards and registrations within the prescribed time limits to avoid loss of warranty coverage.

NOTICE TO QUEBEC RESIDENTS UNDER THE QUEBEC CONSUMER PROTECTION ACT – NO GUARANTEE OF AVAILABILITY OF REPLACEMENT PARTS AND REPAIR SERVICES

Most RVs are covered by a 2-year Limited Warranty. ***Please see our full warranty terms and conditions here, which also include a list of the RVs and their components covered by that Limited Warranty.***

Beyond the terms of the Limited Warranty, Jayco does not warrant or guarantee the availability of, and hereby explicitly disclaims any implied, statutory or other warranty or guarantee of availability of, any spare or replacement parts, repair services or information necessary for the maintenance or repair of RVs, their components or any other product offered for sale by Jayco.

NOTICE TO CALIFORNIA CUSTOMERS ONLY: Jayco, Inc. has elected to follow the procedures described in Cal. Civ. Proc. Code § 871.20 et seq., regarding pre-litigation notice requirements for consumer claims brought pursuant to the Song Beverly Consumer Warranty Act.

WARNING: Read all instructions in this manual and component manufacturer supplied information before using your RV.

This manual has been provided by your recreational vehicle manufacturer for the sole purpose of providing instructions concerning the operation and maintenance of this recreational vehicle. Nothing in this manual creates any warranty, either expressed or implied.

The owner's failure to provide required service and/or maintenance could result in the loss of warranty. Please review the limited warranty and the limited warranties that apply to specific components offered with this vehicle.

Instructions are included in the manual for operating various components which are optional on some RV's or may not be available on your particular model. **"If equipped" does not indicate or imply that the component(s) or option(s) were at any time available, or can be retrofitted to your model.** In addition, the owner should refer to individual manufacturer's operating instructions contained in the customer information packet.

CHASSIS GUIDE

Throughout this manual, frequent reference is made to the vehicle's Chassis Guide. The Chassis Guide includes the owner's manual provided by the manufacturer of the chassis on which this motor home is built, warranty cards and/or registrations. It also includes pertinent information regarding the transmission, tires, etc. Consult the Chassis Guide for operating safety, maintenance, servicing instructions and warranty coverage. The Chassis Guide should be considered a permanent component of the vehicle and kept in the motorhome at all times for reference.

SAFETY ALERTS

Throughout this manual, certain items are labeled NOTE, NOTICE, CAUTION, WARNING, and DANGER. These signal words indicate precautions and potential situations, which if not avoided, may result in personal injury, property damage, or damage to your RV. These precautions are listed in the appropriate areas in this Owner's Manual, and in the information contained in the Warranty Packet, and on safety labels affixed to your RV. Read and follow them carefully.

National Safety Associations and organizations require many of the instructions listed. Always use the appropriate safety gear when servicing or maintaining your RV. Please call your dealer or our customer service representatives if you are unsure how to proceed.

WARNINGS AND OTHER LABELS

Informational labels will be attached at various locations on the interior and exterior of your RV. These labels are there for your guidance and protection, and should never be tampered with or removed.

NOTE

Gives helpful information.

NOTICE

Indicates a potential situation that, if not avoided, may result in property damage or damage to your RV.



This is the safety alert symbol. It is used to alert you to potential personal injury hazards. Obey all safety messages that follow this symbol to avoid possible injury or death.

CAUTION

Indicates a potentially hazardous situation that, if not avoided, may result in minor or moderate injury. It may also be used to alert against unsafe practices.

WARNING

Indicates a potentially hazardous situation that, if not avoided, may result in death or serious injury.

DANGER

Indicates an imminently hazardous situation that, if not avoided, will result in death or serious injury. This alert information is limited to the most extreme situations.



TABLE OF CONTENTS

INTRODUCTION

SECTION 2: OCCUPANT SAFETY

SECTION 3: PRE TRAVEL INFORMATION

SECTION 4: VEHICLE OPERATION

SECTION 5: ELECTRICAL

SECTION 6: FUEL & PROPANE SYSTEM

SECTION 7: PLUMBING SYSTEM

SECTION 8: HEATING & COOLING

SECTION 9: APPLIANCES

SECTION 10: ELECTRONICS

SECTION 11: INTERIOR

SECTION 12: EXTERIOR

SECTION 13: CHECKLISTS

SECTION 14: ADDITIONAL INFORMATION



TABLE OF CONTENTS

INTRODUCTION

ASCEND COMMUNITY	3
ABOUT THIS MANUAL	4
CUSTOMER INFORMATION PACKET	4
CHASSIS GUIDE	4
SAFETY ALERTS	4
WARNINGS AND OTHER LABELS	5

SECTION 2: OCCUPANT SAFETY

FIRE SAFETY	10
FIRE EXTINGUISHER	10
SMOKE ALARM	10
COMBINATION CARBON MONOXIDE /PROPANE ALARM (IF EQUIPPED)	11
CARBON MONOXIDE ALARM (IF EQUIPPED)	11
FORMALDEHYDE	11
EXTENDED OR FULL TIME USAGE	11
CONDENSATION	11
COLD WEATHER USAGE	12

SECTION 3: PRE TRAVEL INFORMATION

VEHICLE LABELS	14
LOADING YOUR MOTOR HOME	16
ROOF RACK (IF EQUIPPED)	16
TRAILER PLUG	16
WEIGHING YOUR MOTOR HOME	16

SECTION 4: VEHICLE OPERATION

VEHICLE OPERATION	18
TOWING BEHIND YOUR MOTOR HOME	18
RUNNING BOARDS/REAR BUMPER ENTRY ASSIST	19
DRIVER AND PASSENGER SEAT	19
SEAT BELTS	19
CHILD SAFETY RESTRAINT SYSTEMS (IF EQUIPPED)	20
VEHICLE DASH	20
OUTSIDE REARVIEW MIRRORS	20
REAR VISION CAMERA	20
CAMPSITE HOOK-UP	20
EMERGENCY STOPPING	21
EMERGENCY TOWING	21
FRONT AXLE TIRE ALIGNMENT	21
WHEEL LUG NUTS/WHEEL LINERS	21
TIRES	22
CHANGING A TIRE	22

AOWNINGS	22
----------------	----

SECTION 5: ELECTRICAL

THE ELECTRICAL SYSTEM	26
COMMAND CENTER (IF EQUIPPED)	27
FIREFLY MULTIPLEX SYSTEM (IF EQUIPPED)	27
GFCI CIRCUIT BREAKERS	27
TESTING THE CAMPSITE POWER CONNECTION	27
PROGRESSIVE DYNAMICS INVERTER (IF EQUIPPED)	28
12-VOLT DC SYSTEM	29
BATTERIES - LEAD ACID (IF EQUIPPED)	29
BATTERIES - LITHIUM (IF EQUIPPED)	30
LOAD CENTER	31
APPROXIMATE ELECTRICAL LOAD RATINGS	31
AUTOMATIC TRANSFER SWITCH (ATS)(IF EQUIPPED)	32
GENERATOR (IF EQUIPPED)	32
STARTING THE GENERATOR	32
SOLAR PREP (IF EQUIPPED)	33
SOLAR PANEL (IF EQUIPPED)	33
SOLAR ENERGY SYSTEM - LITHIUM (IF EQUIPPED)	34
POWER SHARE SWITCH	34
HIGH IDLE START STOP - SPRINTER CHASSIS (IF EQUIPPED)	34
HIGH IDLE START STOP - PROMASTER CHASSIS (IF EQUIPPED)	34
HIGH IDLE START STOP - TRANSIT CHASSIS (IF EQUIPPED)	36

SECTION 6: FUEL & PROPANE SYSTEM

EXHAUST GAS FUMES	39
FUEL SAFETY	39
PROPANE GAS SYSTEM (IF EQUIPPED)	39
PROPANE USE AND SAFETY (IF EQUIPPED)	41

SECTION 7: PLUMBING SYSTEM

PLUMBING SYSTEM	44
FRESH WATER SYSTEM	44
WATER PURIFICATION SYSTEM	45
DRAINING THE FRESH WATER SYSTEM	45
UTILITY CENTER	46
SANITIZING THE PLUMBING SYSTEM	48
WINTERIZING THE PLUMBING SYSTEM	49
TRUMA® COMBI DIESEL 2 in 1 SYSTEM (IF EQUIPPED)	54
AQUA-HOT® WATER HEATER (IF EQUIPPED)	54
TIMBERLINE FURNACE/WATER HEATER (IF EQUIPPED)	54
FAUCETS	55

TABLE OF CONTENTS

BATHROOM TUB / SHOWER.....	55
SHOWER MISER.....	55
BLACK/GREY WATER SYSTEM AND TANKS.....	56
BLACK AND GREY TANK DRAINS.....	56
TANK HEATERS (IF EQUIPPED).....	57

SECTION 8: HEATING & COOLING

AIR CONDITIONER.....	60
TRUMA® COMBI DIESEL 2 in 1 SYSTEM (IF EQUIPPED).....	61
FURNACE (IF EQUIPPED).....	61
POWER ROOF VENT.....	61

SECTION 9: APPLIANCES

COOKING SAFETY.....	63
COOKTOPS, RANGE AND OVEN (IF EQUIPPED).....	63
INDUCTION COOKTOP (IF EQUIPPED).....	64
MICROWAVE.....	64
REFRIGERATOR.....	64
LP GAS GRILL HOOKUP (IF EQUIPPED).....	65

SECTION 10: ELECTRONICS

WINEGARD CONNECT 2.0 (IF EQUIPPED).....	67
---	----

SECTION 11: INTERIOR

CLEANING THE INTERIOR.....	68
SOFA AND DINETTE (IF EQUIPPED).....	69
CEILING FABRIC.....	69
COUNTERTOPS.....	70
FLOORING.....	70
FLOORING TOP SEAL.....	70
THIRD SEAT AND TABLE(S).....	70
POWER BUNK BED (IF EQUIPPED).....	71
BUNK BEDS AND BUNK LADDERS (IF EQUIPPED).....	72

SECTION 12: EXTERIOR

CLEANING THE EXTERIOR.....	74
FRAME.....	75
FIXED EXTERIOR LADDER (IF EQUIPPED).....	75
EXTERIOR HOOKED LADDER (IF EQUIPPED).....	75
EXTERIOR ROOF AND SIDEWALL VENTS.....	75
WINDOWS.....	75
SEALANTS.....	76

SECTION 13: CHECKLISTS

MOTOR HOME STORAGE.....	78
TRAVEL CHECKLIST.....	79

SECTION 14: ADDITIONAL INFORMATION

HELPFUL LINKS.....	80
--------------------	----

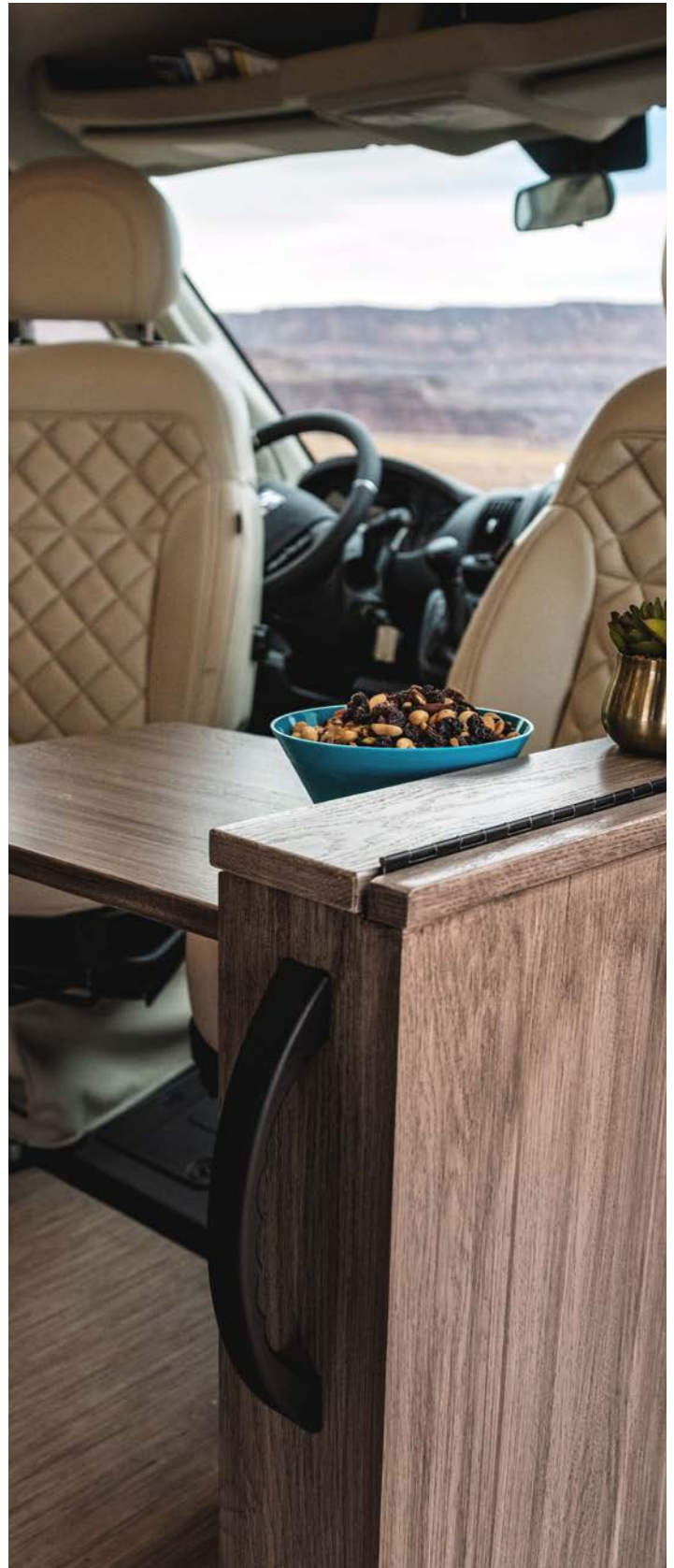

SECTION 2: OCCUPANT SAFETY



FIRE SAFETY

If a fire does start, follow these basic safety rules:

1. Evacuate the vehicle immediately and call 911.
2. After everyone is accounted for, check the fire to see if you can attempt to put it out.
3. If it is large, or the fire is fuel-fed, get clear of the vehicle and have the Fire Department handle the emergency.
4. Do not attempt to use water to put out the fire. Water can spread some types of fire, and electrocution is possible with an electrical fire.

Refer to the following sections for additional fire safety information.

- Electrical Systems, In case of an electrical fire.
- Appliances, In case of a grease fire.

FIRE EXTINGUISHER

⚠ DANGER ⚠ **⚠ WARNING ⚠** (See page 10) & (See page 12)

Fire extinguishers are classified and rated by fire type, A, B and C. These classifications identify the kinds of fires or burning materials they are designed to fight.

- **Class A** - Solid materials such as wood, paper, cloth, rubber and some plastics.
- **Class B** - Liquids such as grease, cooking oils, gasoline, kerosene or other flammable liquids.
- **Class C** - Electrical such as electrical wires or other live electrical equipment.

A dry chemical fire extinguisher has been installed by the entrance door. It is suitable for extinguishing small fires of the Class B or C type only.

We suggest you become thoroughly familiar with the operating instructions displayed on the side of the fire extinguisher.

NOTE

For information on how to use your fire extinguisher, refer to the fire extinguisher user's manual included in your warranty packet.

Inspection And Maintenance

Read and follow all instructions on the label and user's manual provided by the fire extinguisher manufacturer.

NOTE

Inspect the extinguisher at least once a week (more frequently if it is exposed to weather or possible tampering). This should also be done before beginning a vacation or during an extended trip.

SMOKE ALARM

⚠ WARNING ⚠ (See page 8)

Your recreation vehicle is equipped with a smoke alarm that is listed for use in recreation vehicles. The smoke alarm will only work if it is operational and maintained. **Refer to the manufacturer's user guide for detailed safety and operating information.**

Smoke Alarms have a limited life and will wear out over time. Immediately replace the detector if it is not working properly, if it displays any type of problem, or within five years of use.

Though the alarm horn in this detector meets or exceeds current UL standards, it may not be heard for reasons that include (but not limited to): a closed or partially closed door, other noise from electronics, appliances or traffic.

COMBINATION CARBON MONOXIDE /PROPANE ALARM (IF EQUIPPED)

⚠ DANGER ⚠ **⚠ WARNING ⚠** (See page 11) & (See page 13)

Your RV is equipped with a combination carbon monoxide (CO) / propane alarm specifically designed for RV use. This alarm is wired directly to the 12-volt electrical system, powered continuously by the RV batteries. If the battery cable is disconnected, the alarm will not function.



Carbon monoxide/ Propane alarm (alarm may vary)

It's essential to read, understand, and adhere to the owner's information provided by the manufacturer of the combination CO/propane alarm. This includes details regarding the limited life of the alarm.

Carbon monoxide (CO) is a silent and deadly gas. It's odorless, colorless, and tasteless, making it difficult to detect. Symptoms of CO poisoning should be discussed with all household members:

- Mild exposure: Slight headache, nausea, vomiting, fatigue (similar to flu-like symptoms).
- Medium exposure: Severe headaches, drowsiness, confusion, rapid heart rate.
- Extreme exposure: Unconsciousness, convulsions, cardiac and respiratory failure, death.

Your combination carbon monoxide/propane alarm is designed to detect toxic fumes resulting from incomplete combustion, such as those from appliances, furnaces, fireplaces, and auto exhaust.

Maintenance

- Vacuum the alarm cover annually. Clean it by hand using a damp cloth and dry with a soft cloth. Avoid spraying cleaning agents or waxes on the alarm's front panel, as this may damage the sensor.
- Do not paint the face of the alarm.
- Refer to the manufacturer's user manual for additional information on functions and alarm testing.
- Test the alarm after storage, before each trip, and at least once per week during use.

CARBON MONOXIDE ALARM (IF EQUIPPED)

⚠ WARNING ⚠ (See page 11)

Your recreational vehicle may come equipped with a carbon monoxide (CO) alarm specifically designed for RV use. It's essential to ensure the alarm is operational and maintained. For detailed safety and operating information, refer to the manufacturer's user guide.

The alarm is wired directly to the 12-volt electrical system, drawing power continuously from the RV batteries. There's no 9-volt battery backup. While the current draw is minimal, extended storage periods could potentially drain the batteries if the inverter cannot recharge them. Disconnecting the battery cable renders the alarm inactive.

The alarm detects toxic CO fumes from incomplete combustion, emitted by appliances, furnaces, fireplaces, and vehicle exhaust. While primarily for CO detection, the alarm may also detect other combustible fumes or vapors, including acetone, alcohol, butane, and gasoline, commonly found in household items. High temperatures can activate glue and adhesive vapors, which may persist in the RV for extended periods, particularly in hot weather. If the CO alarm sounds with a 4-chirp pattern:

1. Move to fresh air immediately, outdoors or by an open door or window. Account for all occupants.
2. Do not re-enter the RV until emergency services arrive, the premises are aired out, and the CO alarm returns to normal.
3. Call emergency services or 911.

If the CO alarm reactivates within 24 hours:

1. Repeat steps 1-2 and call a qualified appliance technician to inspect fuel-burning equipment and appliances for sources of CO and ensure proper operation.
2. Service identified equipment immediately. Ensure no motor vehicles operate in attached garages or adjacent areas.

FORMALDEHYDE

Some components in the recreation vehicle contain formaldehyde-based adhesives that may release formaldehyde fumes into the air for an unknown period of time. Individuals who are allergic to formaldehyde gas fumes may experience irritation to eyes, ears, nose and throat. Indoor air quality may also be affected by leaving your vehicle closed for a period of time.

To aid in dissipation, ventilate the recreation vehicle by opening all windows and circulate the air with a fan.

This label is located inside the vehicle near the entry door. **The label should be left permanently affixed to the recreation vehicle.**



EXTENDED OR FULL TIME USAGE

⚠ CAUTION ⚠ (See page 10)

Your new recreation vehicle has been built for enjoyment in a recreational manner. It is not intended for use as full-time quarters or a permanent residence. Continuous living in your vehicle could cause accelerated wear and damage to the various components.

CONDENSATION

⚠ WARNING ⚠ (See page 11)

Condensation is a natural phenomenon. The amount of condensation will vary with climate conditions, particularly the relative humidity.

Condensation occurs because there is water vapor present in the air. When the temperature reaches the "dew point" the water vapor in the air condenses and changes to a liquid form.

Proper ventilation or the use of a dehumidifier (customer supplied) will assist in controlling the condensation. Suggestions to eliminate warm moist air:

- Crack open windows and roof vents to allow warm moist air to escape.
- Open the bath roof vent (if so equipped) approximately 1/2" when showering.
- Use the range hood fan (if so equipped) when cooking or washing dishes.

OCCUPANT SAFETY

- Avoid hanging wet towels (or clothes) inside the recreation vehicle to dry.
- If found in cabinets or closets, open the doors slightly to provide ventilation.

COLD WEATHER USAGE

When used in freezing or below freezing temperatures, the precautions should be taken:

- Fresh water and drainage systems - preparations to avoid freeze-ups.
- Propane gas (if so equipped) and sufficient power is needed for protection from possible freeze-ups on the propane gas regulator. Keep in mind that more frequent furnace operation will substantially increase battery draw and propane gas use.
- During cool weather usage, ventilation or addition of a dehumidifier may be required to reduce condensation.
- Check outside extrusions on compartment doors, locks, slide outs, windows, vents, etc., for frozen moisture before operating to avoid damage to parts.



OCCUPANT SAFETY DANGER

FIRE EXTINGUISHER (See page 10)

Do not turn the electrical power back on or plug in any appliances after the use of a fire extinguisher. Please refer to the fire extinguisher's user manual for further instructions on maintenance and clean up.



OCCUPANT SAFETY WARNING

FIRE EXTINGUISHER (See page 10)

Do not check the pressure, test or practice using the fire extinguisher by squeezing the trigger, even briefly. The fire extinguisher is not rechargeable or refillable. Once used, it will gradually lose pressure and will not be fully charged for use in an emergency.

**COMBO CO2/PROPANE ALARM (See page 11)**

- Do not cover or obstruct the carbon monoxide/propane alarm with anything that could prevent gas from entering the alarm.
- This alarm is not designed to detect smoke, fire or gases other than carbon monoxide and propane.
- The carbon monoxide detector installed is intended for use in ordinary indoor locations of recreation vehicles. It is not designed to comply with Occupational Safety and Health Administration (OSHA) commercial or industrial standards.
- Do not disconnect the battery or the alarm.
- Individuals with medical problems may consider using warning devices that provide audible and visual signals for carbon monoxide concentrations under 30 PPM.
- This alarm will only indicate the presence of carbon monoxide gas at the sensor. Carbon monoxide gas may be present in other areas.
- The ultimate responsibility for protection against toxic carbon monoxide fumes rests solely on you. Installing a carbon monoxide/propane alarm is just the first step in protecting your family from toxic carbon monoxide poisoning. The following symptoms are related to carbon monoxide poisoning and should be discussed with all members of the household:
 - » Mild exposure: Slight headache, nausea, vomiting, fatigue (often described as “flu-like” symptoms).
 - » Medium exposure: Severe throbbing headaches, drowsiness, confusion, fast heart rate
 - » Extreme exposure: Unconsciousness, convulsions, cardio-respiratory failure, death
- Actuation of this detector indicates the presence of carbon monoxide which can kill you.
- Never turn the battery disconnect control to the off position and disconnect the battery cable to silence an alarm. The alarm will automatically sense when the level of carbon monoxide in the air reaches below dangerous levels. You should stay outside the vehicle in fresh air until the alarm is silenced. When the alarm sounds, do not stand too close to the alarm. The sound produced by the alarm is loud (85db) because it is designed to wake a person in an emergency. Prolonged exposure to the alarm at a close distance may be harmful to your hearing.

CONDENSATION (See page 11)

Condensation may cause dampness, mildew, mold, staining and, if allowed to continue, it may result in damage to the recreation vehicle (damage caused by condensation is not warrantable). It can also lead to mold or mildew issues, which could be a health hazard.

SMOKE ALARM (See page 10)

- **This smoke alarm will not alert hearing impaired residents.** Special alarms with flashing strobe lights are recommended for the hearing impaired
- Smoke Alarms cannot work without power. Battery operated units cannot work if the batteries are missing, disconnected or dead, if the wrong type of batteries are used, or if the batteries are not installed correctly.
- Only use the replacement battery recommended by the smoke detector manufacturer. The smoke detector alarm may not operate properly with other batteries. Never use a rechargeable battery as it may not provide a constant charge. Never disconnect the battery to silence the alarm.
- Smoke Alarms cannot detect fires if the smoke does not reach the Alarms. Anything preventing smoke from reaching the alarm may delay or prevent an alarm.
- Test the smoke alarm operation after the vehicle has been in storage, before each trip and at least once per week during use. Do not disconnect the battery or the alarm.
- Smoke Alarms are not foolproof and cannot prevent or extinguish fires.

**OCCUPANT SAFETY CAUTION****EXTENDED/FULL TIME USAGE (See page 11)**

Continuous or permanent living in your recreation vehicle may affect your warranty coverage and may void the “Limited Warranty” applicable to your vehicle.

SECTION 3: PRE TRAVEL INFORMATION



VEHICLE LABELS

⚠ WARNING ⚠ (See (See page 17))

Decals and data plates used throughout the motor home aid in its safe and efficient operation; others give service instructions. Read all decals, data and instruction plates before operating your recreation vehicle. Any decal, data or instruction plate painted over, damaged or removed should be replaced.

Keep a record of the 17-digit chassis vehicle identification number (VIN), the 8-digit serial number, and your license number in the event theft or vandalism requires you to supply this information to the authorities.

Weight Terms

GAWR - Gross Axle Weight Rating: The value specified by the vehicle manufacturer as the load-carrying capacity of a single axle system, as measured at the tire-to-ground interfaces. This is the total weight a given axle is capable of carrying.

GCWR - Gross Combined Weight Rating: The value specified by the motor home manufacturer as the maximum allowable loaded weight of the motor home in combination with its towed trailer or towed vehicle. The tongue weight of a towed vehicle/ trailer counts as part of the motor home cargo.

GVWR - Gross Vehicle Weight Rating: The value specified by the manufacturer as the maximum permissible weight of the fully loaded motor home.

OCCC - Occupant and Cargo Carrying Capacity: Is equal to the GVWR of the motor home minus the:

- weight of the motor home, as completed at the factory
- weight of all occupants, including the driver
- weight of all personal cargo
- weight of a full tank of chassis engine fuel
- weight of a full tank of propane (if applicable)

The full weight of potable water, including the water heater and the tongue weight of a towed vehicle/ trailer counts as cargo in or on the motor home. Additions to or other changes made to the motor home after it left the factory will affect (reduce) the OCCC.

UVW - Unloaded Vehicle Weight: The weight of this motor home as manufactured at the factory with fuel, engine oil and coolants and if applicable, the weight of a full tank of propane.

Weight and Capacity Labels

The following labels are located on the inward-facing surface of the main entry door of the motor home and on the lower sidewall left of the driver's seat.

PRE TRAVEL INFORMATION

OCCE Label (Occupant and Cargo Carrying Capacity): The upper portion of this yellow label is federally required and indicates the total combined weight value of occupants and cargo that may be placed in or on your motor home as it was manufactured and weighed before leaving the factory.

This label also indicates the number of safety seat belts that have been installed at the factory. Additions or other changes made to the motor home after it left the factory will affect (reduce) the OCCE.

The lower portion of the label is provided voluntarily and indicates the weight value of the motor home as it was manufactured and weighed before leaving the factory. This label also indicates the GCWR of the completed motor home.

The Federal Certification Label is required by the government to verify the RV complies with all motor vehicle standards for Canada and the United States. It includes the following information: Manufacturer name, VIN, GVWR, GAWR (front/rear), tire and rim sizes and cold tire inflation pressures.

MFG. BY: INC. VEHICLE MFG. BY/	XXXXXX XXXXXXXXXX		Date: XX/XX
V.I.N./N.I.V. XXXXXXXXXXXXXXXXXX		XXXXXXXXXX	
GVWR KG/LBS XXXX / XXXX	SIZE/DIMENSION		
GAWR KG/LBS	TIRE	RIMS	COLD INFL. KPA / PSI
XXXX / XXXX	FRONT INT	XXX/XXXXXX	XXX x XXX
XXXX / XXXX	REAR	XXX/XXXXXX	XXX x XXX
			SINGLE
			DUAL
TYPE OF VEHICLE: MPV, MOTORHOME			
THIS VEHICLE CONFORMS TO ALL APPLICABLE U.S. FEDERAL MOTOR VEHICLE SAFETY STANDARDS IN EFFECT ON THE DATE OF MANUFACTURE SHOWN ABOVE.			

Federal Certification Label

Vehicle Alterer's Label

Required by the government to verify the RV complies with all motor vehicle standards for Canada and the United States. It includes the following information: Manufacturer name, VIN and the date.

VIN / NIV: XXXXXXXXXXXXXXXXXXXX	(XXXXXXXXXXXXXXXXXX)
THIS VEHICLE WAS ALTERED BY XXXXXXXX IN XX/XX AND AS ALTERED IT CONFORMS TO ALL APPLICABLE FEDERAL MOTOR VEHICLE SAFETY, BUMPER AND THEFT PREVENTION STANDARDS AFFECTED BY THE ALTERATION AND IN EFFECT IN XX/XX	
TYPE: TYPE OF VEHICLE: MULTIPURPOSE PASSENGER VEHICLE / MOTORHOME	

Vehicle Alterer's Label

Tire and Loading Label

Provides information on the tire sizes, cold tire inflation pressures, the VIN and maximum cargo capacity. The maximum cargo capacity listed on the label does not include the weight of a full load of water.

 TIRE AND LOADING INFORMATION RENSEIGNEMENTS SUR LES PNEUS ET LE CHARGEMENT				
SEATING CAPACITY NOMBRE DE PLACES		TOTAL X	FRONT AVANT X	REAR ARRIÈRE X
The combined weight of occupants and cargo should never exceed: XXX kg, XXXX lbs. Le poids total des occupants et du chargement ne doit jamais dépasser : XXX kg, XXXX lbs.				
TIRE PNEU	SIZE DIMENSIONS	COLD TIRE PRESSURE PRESSION DES PNEUS À FROID		SEE OWNERS MANUAL FOR ADDITIONAL INFORMATION VOIR LE MANUEL DE L'USAGER POUR PLUS DE RENSEIGNEMENTS
FRONT AVANT	XXXXX/XXXXX X	XXX kPa, XX psi		
REAR ARRIÈRE	XXXXX/XXXXX X	XXX kPa, XX psi		
SPARE DE SECOURS				

Tire and Loading Label

MOTOR HOME OCCUPANT AND CARGO CARRYING CAPACITY

VIN: XXXXXXXXXXXXXXXXXXXX (XXXXXXXXXX)

THE COMBINED WEIGHT OF OCCUPANTS AND CARGO SHOULD NEVER EXCEED:

XXXX kg. OR (XXXX Lbs)

SAFETY BELT EQUIPPED SEATING CAPACITY: X

CAUTION:

A FULL LOAD OF WATER EQUALS XXX kg. or (XXX Lbs) OF CARGO @ 1 kg/L (8.3Lb/gal) AND THE TONGUE WEIGHT OF A TOWED TRAILER COUNTS AS CARGO

Upper Section Federal OCCE Weight Labels

THE WEIGHT OF THIS RECREATION VEHICLE MOTOR HOME AS COMPLETED AT THE FACTORY WITH FULL PROPANE CYLINDER(S) AND FULL GENERATOR FUEL IF APPLICABLE IS: XXXX kg. OR (XXXX Lbs.)

THE GCWR OF THIS RECREATION VEHICLE MOTOR HOME IS XXXX kg. OR (XXXX Lbs.) CONSULT YOUR DEALER AND SEE OWNER'S MANUAL FOR DEFINITIONS, ADDITIONAL WEIGHT LOADING, WEIGHING INFORMATION AND TOWING GUIDELINES INCLUDING AUXILIARY BRAKE REQUIREMENTS FOR ANY TOWED TRAILER OR VEHICLE

RECREATIONAL VEHICLE OVERALL LENGTH XXX M (XX FT. X IN.) EXCLUDING RV APPURTENANCES AS DEFINED BY THE RV MANUFACTURER.

Lower Section Federal OCCE Weight Labels

The motor home towing and braking label is located on the rear bumper above the hitch receiver. Be sure to read and follow the guidelines and information stated on this label. Refer to the Chassis Guide for additional information.

For more information: Consult a hitch specialist or your dealer for assistance when preparing your motor home for towing a vehicle or trailer.

WARNING

The braking capacity of your motor home is not necessarily as great as its towing capacity. Separate braking systems should be used for control of a towed vehicle, (auto, trailer, boat etc.), behind the motor home. Braking requirements will vary by chassis type, chassis manufacturer and state law. Contact your chassis dealer or independent RV dealer for assistance to determine if a separate braking system is recommended and what limit(s) may apply for your towing combination and traveling safety.

The use of a reducing sleeve and smaller diameter draw bar or a longer draw bar in and on the hitch receiver will reduce the hitch weight rating and towing capacity. Use of a draw bar longer than 18-inches (457mm) is prohibited.

Consult your vehicle owner's manual(s) and your independent RV dealer for specific weighing instructions and towing guidelines.

Improper use of towing equipment and towing setups can cause loss of control that may lead to an accident resulting in death or serious injury.

Motor Home Towing and Braking Label

PRE TRAVEL INFORMATION

LOADING YOUR MOTOR HOME

⚠ WARNING ⚠ (See page 17)

When loading heavy objects keep them as low as possible, preferably on the floor. Store and secure all loose items inside the motor home before traveling. Overlooked items can become dangerous projectiles during a sudden stop.

Distribute cargo side-to-side so the weight on each tire does not exceed one-half of the GAWR for either axle. Make sure any tie down straps (if so equipped) on appliances or furniture are secure. Load heavy objects on the floor, or as low as possible.

ROOF RACK (IF EQUIPPED)

⚠ WARNING ⚠ **⚠ CAUTION ⚠** (See page 17) & (See page 17)

Refer to the roof rack manufacturer's owner's manual for detailed safety and user information.

TRAILER PLUG

If you choose to tow behind your RV, a trailer plug (located at the hitch) is pre-wired into your motor home. Before hitching up to a trailer, please read Using the Rear Hitch, vehicle weight ratings, etc. Your motor home will have a 7-way trailer receptacle (combination 4-way / 7-way on some models). Wiring to operate your towed vehicle brakes must be the same size in both the towed vehicle and the motor home.

The connector plug may build up corrosion with extended use. It should be cleaned periodically to insure good electrical contact. Make sure the connector plug is kept clean and protected from road elements as you travel.

NOTE

A 12V circuit tester is recommended to verify trailer connections.

Refer to the manufacturer owner's manual for detailed operating instructions.

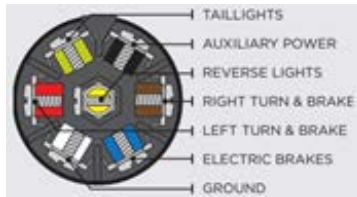

View from Trailer Wire Entry Side

WEIGHING YOUR MOTOR HOME

⚠ WARNING ⚠ **⚠ CAUTION ⚠** (See page 17) & (See page 17)

When your motor home is loaded you should have it weighed. The actual weight of the motor home, passengers, all options, liquids, the hitch weight of your towed vehicle and your personal cargo is important for you to know so you do not exceed the GVWR. There are two important factors when loading your motor home, total weight and balance.

It is imperative that you verify compliance within all applicable weight ratings. Overloading your motor home will void the **Limited Warranty** and the warranties of many component part manufacturers.

Periodically weigh your motor home at a public scale to determine proper load distribution. To obtain the side-to-side weights, there needs to be enough space on either side of the scale to accommodate the motor home being partially off the scale.

Different types or scales may require different procedures when weighting the motor home. The motor home must remain as level as possible on the scale (even if an axle is not physically on the scale). To obtain the side-to-side weights, make sure there is enough space on either side of the scale to accommodate the motor home being partially off the scale.

If a boat, trailer or other vehicle is being towed, it should be weighed separately. Combine this weight with the motor home's Gross Vehicle Weight (GVW) to ensure the total combined weight does not exceed the GCWR.

Once actual weights are obtained, compare them to the **Weight Information Label** weight ratings to ensure you are below the posted minimum ratings.

If there is a difference in the weights on one side of the vehicle as compared to weights on the other side, components (tires, wheels, brakes, springs, etc.) on the heavier side may be overloaded, although the total axle load is within the GAWR.



**VEHICLE LABELS** (See page 14)

The factory-installed weight labels are specific to the recreation vehicle for which they are supplied and are not interchangeable. Do not remove these labels from your vehicle. If labels are missing contact your dealer or Customer Service for replacements.

- **Do not exceed any applicable motor home weight ratings. Doing so could damage your motor home or affect handling and braking characteristics.**
- **Your motor home braking system is designed and rated for operation at GVWR not GCWR.**

ROOF RACK (See page 16)

Do not exceed the weight capacity listed in the manufacturer's owner's manual.

It is critical that you properly all items to the roof rack. You are responsible for securing items to your roof rack, checking the attachments prior to use, and periodically inspecting the products for adjustment, wear, and damage. You should read and understand all of the information supplied with your product prior to installation or use. The roof rack should only be used in accord with the manufacturer's guidelines and weight limits. Failure to properly attach and secure all items to the rack, or using the racks in any way other than specified, may result in property damage or serious injury.

WEIGHING YOUR MOTOR HOME (See page 16)

Dump the gray and black water holding tanks before traveling to avoid carrying unnecessary weight. Full tanks can affect your fuel consumption, and depending on tank location, can affect your vehicle handling characteristics. If you cannot immediately empty your holding tanks, reduce your vehicle speed until you reach a dumping station.

LOADING YOUR MOTOR HOME (See page 16)

- **Never load the motor home in excess of the GVWR or the GAWR for either axle. Overloading your motor home may result in adverse handling characteristics and damage to the chassis.**
- **DO NOT EXCEED YOUR GVWR!** This means you should weigh your vehicle as loaded for your normal travel to determine the actual weight. If you exceed the GVWR, you **MUST** remove items from the motor home, or drain liquids, then re-weigh the vehicle to ensure you have achieved a safe weight.
- The actual weight of the vehicle, passengers, all options, liquids, the hitch weight of your towed vehicle and your personal cargo is important for you to know so you do not exceed the Gross Vehicle Weight Rating (GVWR) of the motor home. The volume of space available for storage may exceed the amount of available cargo capacity. Large storage compartments have been designed to accommodate normal camping items, which are bulky, but not necessarily heavy.
- Your recreation vehicle's load capacity is designated by weight, not by volume, so you cannot necessarily use all available space when loading the vehicle. Do not exceed your GVWR and ensure you are loading the vehicle as evenly as you can for the best possible handling. Ensure heavy items are secured so they do not shift during travel.
- Store items in areas designated for storage. Do not store anything in the areas reserved for the converter, electrical panels, furnace or water heater, etc.
- For traveling safety, it is important to make sure the tie down straps are secured on all appliances such as the toaster, coffee maker, etc. Vibration during travel will move the appliances, creating the potential for them to fall out of their cabinets possibly causing injury.

**WEIGHING YOUR MOTOR HOME** (See page 16)

It is important to redistribute the load to avoid component failure as well as to improve the handling characteristics of the vehicle.

ROOF RACK (page 14)

- Know your recreation vehicles weight limitations prior to loading the roof rack. Items stowed on the roof rack, should be included in the weight calculation when determining the maximum cargo weight load of your motor home.
- When loading the roof rack, evenly distribute the items on the rack. Avoid loading all the heavy items in one spot. Weight of the items should be evenly distributed.
- Make sure all items are secured to the roof rack. Periodically re-check the load to make sure it is still securely fastened and has not shifted.

SECTION 4: VEHICLE OPERATION



VEHICLE OPERATION

⚠ WARNING ⚠ (See page 22)

Your motor home will travel safely and comfortably at highway speed limits. However, it will take longer than a passenger automobile to reach that speed. Allow more time to go around the vehicle you are passing. Avoid situations that might require sudden momentum changes as the length of the motor home affects your ability to quickly cut back into traffic. Swerves and sharp turns, especially at high speeds, could result in loss of control of the motor home.

The motor home has a longer turning radius. When turning, check the road clearance and be aware of others, especially if towing a vehicle behind your motor home.

Adverse weather conditions and extremes in terrain may affect the performance and handling of your vehicle. **Do not** operate the cruise control on icy or extremely wet roads, gravel roads, winding roads, in heavy traffic, or in any other traffic situation where a constant speed cannot be maintained. Use care when accelerating or decelerating on a slippery surface. Abrupt speed changes can cause skidding and loss of control.

NOTE

CALIFORNIA TIRE CHAIN NOTICE: YOUR MOTOR HOME MAY NOT BE OPERATED WITH TIRE CHAINS.

Braking and Stopping

Even though your motor home is equipped with brakes designed for its Gross Vehicle Weight Rating (GVWR) we suggest you practice stopping away from traffic until you become accustomed to your motor

home's stopping distance. Your motor home is equipped with a third brake light that activates when the brakes are engaged.

When descending a long hill, shift the transmission into a lower gear and engage the auxiliary engine braking. If your motor home is equipped with an auxiliary engine brake, engagement is activated by a switch on the driver's console. See the chassis owner's manual for additional information. The distance required to stop the motor home is greater than an automobile's.

Driving through water deep enough to wet the brakes may affect stopping distance or cause the vehicle to pull to one side. Check the motor home's brake operation in a safe area to be sure they have not been affected. **Never operate any vehicle if a difference in braking efficiency is noticeable.**

Parking Brake

The parking brake should be engaged when the motor home is parked. Never drive your motor home with the parking brake engaged as this will reduce braking effectiveness and cause excessive driveline wear. Refer to your Chassis guide for more information on the parking brake.

TOWING BEHIND YOUR MOTOR HOME

⚠ WARNING ⚠ **⚠ CAUTION ⚠** (See page 23) & (See page 25)

Towing will affect vehicle handling, durability and fuel economy. Exceeding any of the listed weight ratings will result in unacceptable overall vehicle performance. Your safety and satisfaction require proper use of correct equipment.

For maximum pulling load and vertical tongue weight, refer to the label located on the rear hitch. A hitch bar of appropriate strength and steel should be selected to meet the capacities of the towing receptor.

Always use safety chains between the motor home and the towed trailer or vehicle. Cross the chains under the tongue and allow for slack when turning corners. Connect the safety chains to the vehicle frame or hook retainers. Never attach the safety chains to the bumper.

Before descending a steep or long grade when towing a trailer or vehicle, reduce speed and shift the motor home into a lower gear to control vehicle speed. Avoid frequent or prolonged brake application, which can cause overheating or brake failure.

By definition the GCWR is “the maximum total weight rating allowed for a vehicle and any attachment, such as a trailer or towed vehicle. To determine the total allowable weight for a towed item, subtract the GVWR from the GCWR.

⚠WARNING:
YOUR MOTORHOME CHASSIS BRAKING SYSTEM IS RATED FOR OPERATION AT GVWR, NOT GCWR. CONSULT YOUR OWNER'S MANUAL(S) FOR SPECIFIC WEIGHING INSTRUCTIONS AND TOWING GUIDELINES. THE BRAKING CAPACITY OF YOUR MOTORHOME IS NOT NECESSARILY AS GREAT AS THE TOWING CAPACITY. SEPARATE BRAKING SYSTEMS MAY BE NECESSARY FOR CONTROL OF A TOWED VEHICLE. (AUTO, TRAILER, BOAT, ETC.) BEHIND THE MOTORHOME. IF THE TOWED VEHICLE MEETS OR EXCEEDS THE MINIMUM WEIGHT AS DETERMINED BY THE CHASSIS MANUFACTURER (THIS MINIMUM WEIGHT RATING WILL VARY BY CHASSIS AND CHASSIS MANUFACTURER), CONTACT YOUR CHASSIS DEALER OR MANUFACTURER FOR ASSISTANCE IN DETERMINING WHETHER A SEPARATE BRAKING SYSTEM IS RECOMMENDED AND WHAT LIMITS THERE ARE FOR YOUR TOWING COMBINATION AND TRAVELING SAFETY.

Towing and Braking Label

In addition, a separate supplemental braking system must be installed if the towed trailer or vehicle meets or exceeds the minimum weight determined by the chassis manufacturer (*this minimum weight rating will vary by chassis and chassis manufacturer*).

Contact your dealer for assistance in determining whether a separate braking system is recommended for your towing and traveling safety. Failure to follow these instructions will create a safety hazard and may result in an accident.

Maintenance

Keep the hitch clean along with your general frame maintenance.

- At the beginning of the season, and monthly or thereafter, clean the inside of the receiver tube with a wire brush and spray with a silicone spray.
- Always remove the utility mount from the receiver when it is not in use. This will help prevent the utility mount from rusting to the tube.
- Periodically check the bolts for tightness. They need to be torqued to the proper setting (refer to your Chassis Guide).

Refer to the chassis manual for detail on hitch specifications and towing guidelines.

RUNNING BOARDS/REAR BUMPER ENTRY ASSIST

⚠ CAUTION ⚠ (See page 25)

Running boards are located on both sides and serve as a step into and out of the vehicle. The rear bumper can be used for entry assist into the rear of the vehicle. When driving, snow, dirt, rocks and other debris can collect on the running boards and bumper. It is imperative to keep these areas clean when using them to enter or exit the vehicle.

DRIVER AND PASSENGER SEAT

⚠ WARNING ⚠ (See page 24)

NOTE

The driver's and front passenger seat must be locked in the forward facing position while the motor home is in motion.

Power Seat (if so equipped)

Use the controls to slide the power seat to the desired position.

Depending on your model, seat controls may be located on the seat or on the door. Release the control, and the seat will lock at that position. Features may include a 3-point adjustable seat belt, lumbar support, swivel, slide and reclining capabilities. (Not all of these features will be available in all motor home models).

To Rotate The Driver/Passenger Seat

Depending on your model, you may have the ability to rotate the driver/passenger seats towards the rear of the motor home. To face the driver or front passenger seat toward the rear of the vehicle, pull the seat swivel release lever up and rotate the seat. To return the seat to the original position, rotate seat back to the driving position until you hear a click and the seat locks into position.

SEAT BELTS

⚠ WARNING ⚠ (See page 24)

Always use seat belts. In an accident, injury to the driver and passengers may be reduced if seat belts are properly used. If your motor home is equipped with a booth dinette, hide-a-bed sofa, or easy bed sofa they will have two-point lap-seat belts installed. **Seat belts should be used in all seating positions.**

Maintenance and inspection of seat belts

The webbing used in seat belts may be cleaned with a mild soap or detergent solution. Allow the belts to dry in the shade and do not allow them to retract until fully dry.

Regularly check the seat belt buckles and release mechanisms for positive action and check automatic locking retractors for positive engagement.

If the seat belt webbing shows obvious cuts, protruding broken fibers or severe fading which indicates weakening by exposure to sunlight, the entire seat belt assembly should be replaced. Do not try to bleach or re-dye the belts. The resulting color may rub off and the webbing strength could be affected.

VEHICLE OPERATION

CHILD SAFETY RESTRAINT SYSTEMS (IF EQUIPPED)

⚠ DANGER ⚠ **⚠ WARNING ⚠** (See page 23)

When transporting infants or small children, an appropriate child safety restraint system should always be used.

NOTE

- All child safety restraint systems should always face the front or rear of the motor home. They should never be installed so the occupant is facing the side of the motor home.
- Children too large for a child safety seat (per government specifications) should always wear a seat belt.

Installing the Child Safety Seat

NOTE

Be sure to read, understand and apply all child seat information provided by the seat manufacturer. Make sure the tether strap is securely and correctly attached to the child safety seat.

Locate the child seat tether anchors (brackets). The anchors will be marked with a child seat symbol. Attach the snap on the strap of the child restraint seat to the corresponding anchor. Adjust the strap so the seat is securely in place. The seat must have both lower straps securely in place. Repeat the process on the upper straps of the child seat.



Child Seat Anchor Symbol



VEHICLE DASH

⚠ WARNING ⚠ (See page 24)

Maintenance:

To clean the vinyl/ABS dash, soak a soft cloth in a solution of mild detergent and water. Wipe off the dash. To rinse, dip a cloth in fresh water and wring it out well. Wipe off the detergent thoroughly.

OUTSIDE REARVIEW MIRRORS

⚠ CAUTION ⚠ (See page 25)

After adjusting the front driver's seat, adjust the outside rearview mirrors to your driving preference. Have someone help you adjust the mirrors in the desired direction for maximum rear visibility before driving. During travel, vibration may loosen the fitting holding the mirror(s), causing them to change position. As part of your regular motor home maintenance, check and adjust the mirrors to the desired position.

Power Remote Mirrors (if so equipped)

You can adjust the power remote mirrors when the ignition key is in the ON position.

1. Move the control knob to the side you want to adjust.
2. Press the control arrows in the direction you want the mirror to move.
3. Return the control knob to the center to lock the mirror(s) into place.



Remote Mirror Control/Mirror Heat Control
(appearance may vary by model)

The power remote mirrors also contain heating elements to defog or de-ice the mirrored glass if needed. To activate this feature, use the "Mirror Heat" control located on the driver's side console next to the mirror control joystick.

NOTE

Depending on models, the mirror control joystick and the Mirror Defrost toggle switch may be separated from each other. The Mirror Defrost switch may be renamed Mirror Heat.

REAR VISION CAMERA

⚠ WARNING ⚠ (See page 24)

The rear vision monitor gives a limited televised view of what is behind your motor home. The rear vision camera will aid you in backing up the motor home, and can be used for a greater field of vision when driving in heavy traffic. The monitor is operational whenever the engine is running.

For detailed operating and safety information, refer to the manufacturer's user guide.

CAMPSITE HOOK-UP

- Refer to Electrical Systems section before connecting the shore line power cord (when using full hook-up) OR before starting the generator (if equipped) or operating the vehicle on 12-volt power when dry camping.
- Refer to Fuel & Propane System section before using the LP system. Open the LP gas tank valve (if so equipped) slowly. There may be air in the lines and five to thirty seconds of time is needed to bleed air before LP vapor fills the lines.
- Refer to Plumbing Systems section before connecting the fresh water supply or turning ON the water pump or water heater.
- When using full hook-up, connect the sewer hose to the campsite sewer hook-up.
- If applicable, start the refrigerator and the cooling or heating system.

NOTE

For extended dry camping, management of all your resources is essential. Check your battery levels and conserve battery power, use it sparingly.

EMERGENCY STOPPING

⚠ WARNING ⚠ (See page 23)

Always carry road flares or reflective warning signs. Pull off the roadway as far as possible for emergency stopping. Turn ON your vehicle hazard warning flashers. If traveling at night, use three red warning indicators such as flares, reflectors or lanterns as required by the Uniform Vehicle Code and Model Traffic Ordinance as follows:

1. Place the first warning indicator on the traffic side of the recreation vehicle, directed at the nearest approaching traffic.
2. Place the second warning indicator 100 feet behind the recreation vehicle in the center of the lane and toward approaching traffic.
3. Place the third warning indicator 100 feet in front of the recreation vehicle in the center of the lane and away from the traffic approaching from behind.

NOTE

Curves and/or hills may affect the safe placement of warning indicators.

EMERGENCY TOWING

⚠ WARNING ⚠ (See page 23)

If your motor home ever needs to be towed, refer to the instructions in your Chassis Guide. Please contact an emergency road service provider or a qualified service facility for assistance.

Make sure the road service technician reads and is familiar with the information contained in your Chassis Guide regarding emergency towing.

FRONT AXLE TIRE ALIGNMENT

The term alignment refers to both the adjustment angles on the steering axle and suspension and tracking of the rear axle. Steering components, suspension, wheel bearings and even proper loading will affect the alignment.

We recommend you have the front suspension and steering alignment checked and adjusted after you have fully loaded the vehicle as part of the vehicle maintenance. Thereafter, it is your responsibility to have the alignment inspected periodically to maintain vehicle steering performance and prevent uneven tire wear as part of your normal maintenance.

After this road test has been completed, front-end alignment and/or vibrations will not be covered as part of the new vehicle limited warranty.

Follow the Chassis Guide maintenance instructions for the front and rear axle for wheel and suspension maintenance, including the brakes and wheel bearings. Contact your Chassis manufacturer for assistance.

NOTE

Always have the alignment checked and adjusted by a qualified shop with the proper equipment to handle heavy vehicles.

A road test by the dealer should be included as part of the pre-delivery inspection. The dealer can check for and correct any steering problems before you take delivery.

WHEEL LUG NUTS/WHEEL LINERS

⚠ WARNING ⚠ (See page 23)

Torque is the amount of rotating force applied to a lug nut, and can only be achieved by using a properly calibrated torque wrench and socket. Do not use a 4-way socket or any other type of wrench that does not measure the actual pressure applied to the lug nut.

NOTE

The proper method of tightening wheel lug nuts is with a torque wrench, not with an impact wrench or by hand. Because of the importance of having proper torque on the wheel lug nuts, you should always have the wheels mounted and properly torqued by a qualified technician using the proper tools.

After your first trip, check the wheel lug torque periodically for safety according to your Chassis Guide. If you suspect the wheel lug nuts have loosened at any time, have them checked and torqued to the proper limits immediately.

Lugs should be checked:

- After winter storage
- After a wheel removal
- Before starting a trip
- Following extensive braking.
- **Check and re-torque after the first 10, 25 and 50 miles (16, 40 and 80 kilometers). Thereafter, check and maintain the torque according to the listed torque values.**

Refer to the Chassis Guide for torque guidelines.

Wheel Lugs

If you suspect or notice the wheel stud bolts are cracked or broken, they must be replaced, along with adjacent bolts that have probably also been weakened due to the additional stress placed on them.

Aluminum Wheels (if so equipped)

Clean the aluminum wheels with a cleaner that is designed for use on aluminum and apply an appropriate protection agent. Do not use abrasive cleaners. Wheels exposed to sea water or road chemicals should be cleaned as soon as possible. Be sure to use a sponge or chamois leather (brushes may damage the aluminum wheel surface).

NOTE

If your motor home is equipped with aluminum wheels, only the outer dual wheels are aluminum, the inner duals are steel wheels.

VEHICLE OPERATION

TIRES

⚠ CAUTION ⚠ (See page 25)

Read and understand the following before taking your first trip in your RV.

Routine maintenance on your RV is important. **To ensure your tires are operating safely, regular inspection of the tires and checking tire pressures is absolutely mandatory.**

Alignment, balance and bearing wear will affect tire wear. Make sure to look for cracking, bulging, uneven tread wear, etc.

Tire Wear Diagnostic Chart

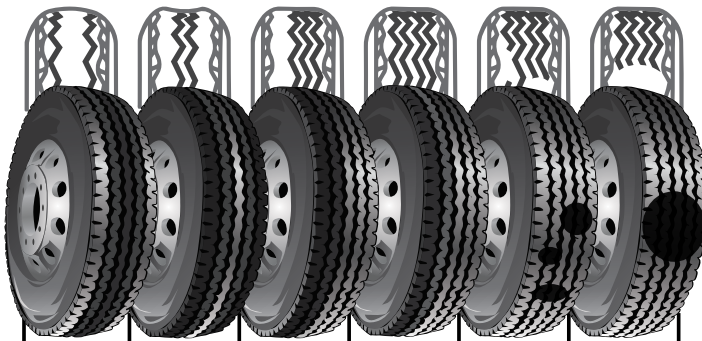

Center Wear	Edge Wear	Side Wear	Toe Wear	Cupping	Flat Spots
Cause					
Over inflation	Under inflation	Loss of camber or overloading	Incorrect toe-in	Out of balance	Wheel lock-up & tire skidding
Action					
Adjust tire pressure to particular load, per tire catalog.	Adjust tire pressure to particular load, per tire catalog.	Insure load does not exceed axle rating. Align at alignment shop.	Align at alignment shop.	Check bearing adjustment & balance tires.	Avoid sudden stops when possible and adjust brakes.

Tire Pressure

⚠ DANGER ⚠ **⚠ WARNING ⚠** ((See page 23) & (See page 24))

You must follow the manufacturer's inflation guidelines for maximum load capacity; under-inflation is just as dangerous as over-inflation.

Proper inflation should be monitored closely. Failure to do so could result in the overheating of a tire causing a blowout. Inflation pressure should be as recommended by the tire manufacturer or as the federal label for the recreation vehicle indicates.

When you are using your Recreation Vehicle, check inflation pressure weekly. Pressure should be checked when the tires are cold. During travel, tires heat up and pressure increases. **Do not bleed air from hot tires or your tires may then be under-inflated.**

NOTE

Cold tire inflation pressure is defined as a tire that has not been used for three or more hours, or has been driven less than one mile. Tire inflation pressure of a hot tire may show an increase of as much as 6 psi over a cold tire.

CHANGING A TIRE

⚠ WARNING ⚠ (See page 24)

If you experience a flat tire on your motor home while driving, gradually decrease your vehicle speed (if possible), and move the motor home to a safe place on the side of the road. Contact your road service provider (if applicable) or a qualified service facility for assistance. **Do not attempt to change the tire or jack the motor home up yourself.**

Make sure the road service technician reads and is familiar with the Chassis Guide information regarding changing the tires. Make sure the wheel lug nuts have been tightened to the proper torque as outlined in your Chassis Guide.

AWNINGS

⚠ WARNING ⚠ **⚠ CAUTION ⚠** (See page 23) & (See page 25)

The following is an overview on awning care. **Refer to the manufacturers user guide for additional details on set up and use.**

Awning Care

Keep your awnings clean and in good condition to prevent costly repairs.

- Keep the awning fabric clean. For detailed cleaning information, refer to the manufacturer's owner information.
- Do **not** use insecticides or other sprays near the awning fabric. These can cause stains, and could adversely affect the fabric's ability to repel water.
- Do **not** expose the awning to adverse environmental conditions, corrosive agents, or other harmful conditions.
- **Never** close the awning (for storage) when wet. The combination of moisture and dirt could result in mildew, discoloration, and stains. If it is necessary to roll up awning (temporarily) while it is wet, make sure you roll it out and let it dry (as soon as conditions allow) before rolling it up again.
- Do **not** allow dirt, leaves, or other debris to accumulate on the awning, which could cause abrasion and stains. Mildew could grow on dirt and organic debris, causing permanent discoloration, stains, and odors to the awning fabric.
- Do **not** use strong chemicals or abrasives to clean parts, as their protective surfaces will be damaged. Do not use abrasive or corrosive cleaners, mildew removers, or hard bristle brushes.

To Clean The Fabric:

- Open the awning.
 - Vinyl Fabric-use a soft brush, warm water with soap.
 - Acrylic Fabric-use a stiff brush, warm water with soap.
- Always use a natural soap, not a detergent.
- The water should be cold to lukewarm, never more the 100° F.
- Air-dry only.
- Never apply heat to the fabric.
- Make sure the fabric is dry before closing the awning.



CHILD SAFETY RESTRAINT SYSTEMS (See page 20)

- Never allow a passenger to hold a child on their lap while the motor home is moving. The use of safety seats for children are required when transporting a child in your motor home. All child age and weight guidelines as specified by law should be strictly adhered to.
- Rear facing child seats or infant carriers, or child booster seats should never be placed in the front seats of the motor home.

Failure to follow these guidelines can result in serious injury or death.

TIRE PRESSURE (See page 22)

Failure to follow proper inflation guidelines may result in tire failure, which, under certain circumstances can cause loss of vehicle control or accidents that may result in property damage, bodily injury and/or death.



TOWING BEHIND YOUR MOTOR HOME (See page 18)

- **Total weight of your motor home and any trailer or vehicle towed by it must not exceed the GCWR.** Do not assume that you can tow a vehicle that happens to be within the capacity of the hitch. By doing so, you may exceed the total GCWR of the motor home.
- **The total weight of your motor home (including cargo, passengers, fluids, etc.) in addition to the vertical (tongue) weight must not exceed the GVWR and/or any GAWR.** Once again, do not assume that you can tow a trailer or vehicle that happens to be within the vertical (tongue) weight capacity of the hitch. By doing so, you may exceed the GVWR and/or GAWR of the motor home.
- **Your motor home chassis braking system is rated for operation at GVWR, NOT GCWR.** Any trailer or vehicle being towed by your motor home must have adequate brakes as required by all state (or province) and local regulations for towing with your motor home, including areas you may be traveling through. **Failure to follow the towing guidelines may result in property damage or injury.**

EMERGENCY STOPPING (See page 21)

For personal safety, always stand off the road and out of the way of traffic.

CHILD SAFETY RESTRAINT SYSTEMS (See page 20)

- Improper installation or failure to properly secure a child restraint may result in failure of the restraint.
- Follow the child restraint manufacturer's directions exactly when installing an infant or child restraint. Be aware of all warnings and safety information included with any infant or child safety restraint system.
- Never place a front or rear facing child restraint in the front seat of a vehicle. A deploying passenger front air bag can cause death or serious injury to a child 12 years or younger, including a child in a child restraint. A child restraint should only be installed in a rear seat.
- To ensure proper safety belt fit, always use booster seats for children who are size and age appropriate. Refer to the governmental safety regulations for child sizing charts.

Failure to follow these guidelines can result in serious injury or death.

EMERGENCY TOWING (See page 21)

- Never allow anyone to go under the motor home while it is being lifted by towing equipment.
- Be aware of the strap locations. Misplaced straps could result in damage to the exterior of your unit. Damage resulting from misplaced straps is the responsibility of the towing company, and is not covered by the unit warranty.

AWNINGS (page 20)

- Awnings must be closed (and secured) while the RV is in transit.
- Keep clear of arm assemblies while opening, adjusting or closing the awning. Failure to obey this caution could result in injury and/or property damage.
- Always operate the awning according to the instructions.
- Periodically check that the fasteners are tight (tighten if necessary).
- Keep the awning fabric and arms clean.

WHEEL LUG NUTS (See page 21)

- Check and tighten the wheel lug nuts regularly to ensure they did not loosen during travel. Refer to your Chassis Guide for torque recommendations.
- Failure to tighten and maintain wheel lug nuts to the proper torque specification, could allow the wheels to come off while driving, resulting in serious injury or property damage in the event of a collision or loss of vehicle control.



VEHICLE OPERATION (page 16)

Your motor home chassis braking system is rated for operation at GVWR not GCWR

SEAT BELTS (See page 19)

Seat belts should always be worn by anyone who drives or rides in this vehicle.

- Never use one seat belt for more than one occupant. Never carry more people in the motor home than there are seat belts.
- Only seats equipped with seat belts are to be occupied while the vehicle is in motion. While traveling, do not occupy beds or any seats that do not have seat belts.
- Be sure to lock all doors before driving. Locking the doors and using the provided seat belts will minimize the risk of injury or ejection in an accident.
- If you are pregnant, consult your health care professional for advice on seat belt use.

REAR VISION CAMERA (See page 20)

- Camera/monitor system aids in the use of, but does not replace vehicle side/rear-view mirrors.
- Objects in camera/monitor view are closer than they appear. When backing up, proceed cautiously and be prepared to stop.

DRIVER AND PASSENGER SEAT (See page 19)

- Do not adjust the seat while driving. After adjusting the seat, make sure that it is locked in position. To ensure that the seat is locked securely, try to move the seat forward or backward without using the adjusting lever or button. Do not put packages, pets or other objects between the driver's and front passenger co-captain's seat.
- **If equipped with reclining seats:** to minimize the risk of personal injury in the event of a collision or sudden stop, always keep both the driver's captain and passenger co-captain seat backs in a nearly upright position while the motor home is moving. The protection provided by the seat belts may be reduced significantly when the seat back is reclined. Reclining the seats while the motor home is moving may result in serious injury.
- **If equipped with power seats:** keep hands and feet clear of the power seat while in operating the power feature.

CHANGING A TIRE (See page 22)

- The motor home is very heavy. Raising the motor home to replace the spare tire should only be done with extreme caution by a qualified technician. The vehicle could slip, causing personal injury or death. **DO NOT ATTEMPT TO DO THIS YOURSELF.**
- When replacing a tire, Replace it with a tire of the same size and specifications (refer to your Chassis Guide for assistance).

TIRE PRESSURE ((See page 22)

It is recommended that the tire pressure be checked at the beginning of each trip to obtain the maximum life of the tire. Follow the instructions listed on the Federal Certification label, to determine the correct tire pressure. Under-inflation may cause tire failures and swaying resulting in loss of control, injury, death or property damage.

VEHICLE DASH (See page 20)

Do not set anything on, or attach anything to, the instrument panel or dash. Do not attach anything to the steering wheel cover. Failure to follow these warnings may restrict the driver's visibility or cause an object to strike and injure an occupant in the case of a collision or sudden stop.



AWNINGS (page 20)

The effects of wind and rain on an awning are unpredictable and can cause severe damage to the awning and/or the recreation vehicle. **Retract the awning if:**

- If wind or extended periods of rain are expected.
- If you leave the RV unattended for a length of time, to avoid unexpected climate conditions.

RUNNING BOARD (page 17)

Care should be taken when using the running boards and bumper as an entry assist if the surfaces are wet.

TOWING BEHIND YOUR MOTOR HOME (See page 18)

Do not install a frame equalizing type hitch on your motor home.

OUTSIDE REARVIEW MIRRORS (See page 20)

Adjust the outside rearview mirrors before driving.

TIRES (See page 22)

Tire wear should be checked frequently. Once a wear pattern becomes firmly established in a tire it is difficult to stop, even if the underlying cause is corrected.



SECTION 5: ELECTRICAL



THE ELECTRICAL SYSTEM

⚠ WARNING ⚠ (See page 38)

The RV electrical system is comprised of two independent electrical systems. One operates off of 12-volt DC power and the other off of 120-volt 60hz AC power. All installations have been made in compliance with industry standards applicable on the date of manufacture. Because the electrical equipment and associated circuitry are engineered into a dedicated system specific to your RV, do not make unauthorized changes or add fixed appliances to it. **Changes or additions made after delivery may result in a hazardous condition.**

Service and/or modification of the electrical system should only be performed by qualified electrical technicians using approved materials, components, and methods meeting current safety and code requirements. Consult your dealer's service department for assistance.

To read more about the various components incorporated into the RV electrical system, please refer to the information contained in your Warranty Packet.

Consult the Chassis Guide for information pertaining to the chassis drivetrain electrical system.

Electrical System Maintenance

Before working on the electrical system:

- Make sure the inverter/charger (if so equipped) is turned "off" before disconnecting batteries.
- Disconnect the shore power cord.
- If equipped with a generator, turn off the generator and disable the automatic generator start functionality.
- Turn off the battery disconnect switch (if so equipped).
- Turn off the 120V main circuit breaker.

Disconnect the negative 12VDC battery terminal from the battery.

Lithium Battery Systems (If Factory Equipped)

An RV with a factory installed lithium battery system has an electrical system that is comprised of the following:

- 12-volt DC power
- 48-volt DC power – Air Conditioner and Inverter/Charger
- 120-volt 60hz AC power – Heat/Water Heater and GFCI Receptacles

Maintenance for an Electrical System with Lithium Batteries

Before working on the electrical system:

- There are two (2) DC disconnect switches installed for the rooftop solar array. One is located on top of the roof and one is located on the interior of the unit. Although the one located on the roof is designated for emergency use, a secondary has been added to the interior for customer convenience. Turning the switch off will disconnect power from the solar array.
- Using Inverter Remote Switch, turn off the inverter.
- Disconnect the shore power cord.
- Turn off the battery disconnect switch.
- Turn off the 120V main circuit breaker.
- Turn off lithium battery. The Battery Self-Lock Switch is located under an access panel in the passenger sofa/bed base.

COMMAND CENTER (IF EQUIPPED)

Command Center Overview:

The command center, located near the entrance or in the living area, features various switches and controls tailored to different RV models.

Panel Features:

- Fuel gauge and hour meter with fuel pump and station switches (if available)
- Red-lighted switches for water heater, generator, tank heaters, and cargo bed
- Light switches for various interior and exterior lights
- Controls for slideouts, awnings, auto-leveling, and power bunk bed lift
- Systems monitor displaying tank levels and battery charge status
- Inverter panel with power switch and display
- Speaker selector switch
- Touch dimmer switch for ceiling lights



Command Center Panel
w/ Switch Modules

Dimmer Functionality:

- Tap to turn ceiling lights ON/OFF
- Press to adjust brightness gradually
- Memory function retains last brightness setting when turned ON again.

NOTE

If your RV model includes the 5 way/8 way remote control, the LIGHT button on the remote only controls the awning LED lights.

FIREFLY MULTIPLEX SYSTEM (IF EQUIPPED)

The Firefly multiplex system controls numerous components in your motor home. Some of these include the air conditioner, generator (if equipped), tank heaters, water pump, awning and lighting.

The MAIN POWER switch located at the mid-ship door area must be turned ON to enable the multiplex system.

The multiplex switch panels are backlit and when a switch is selected, it will light up indicating it is ON. Pressing the switch a second time turns it OFF.

- Refer to the Firefly manual detailed operating instructions.

NOTE

The touchscreen system may require periodic updates and/or downloads. The age of your device or hardware configuration changes may prevent your device from accepting or installing a new system update. If you receive notification that an upgrade is available, please contact Fire Fly Integrations for further information (<http://www.fireflyint.com>). Version number information for your touchscreen is found on the Settings screen of your touchscreen.

GFCI CIRCUIT BREAKERS

⚠ WARNING ⚠ (See page 36)

Ground fault current interrupter breakers have been engineered into the electrical system, and are designed to reduce the possible injury caused by electric shock. The breakers will protect against short circuits or circuit overloads.

TESTING THE CAMPSITE POWER CONNECTION

⚠ WARNING ⚠ (See page 37)

The campsite 120-volt power receptacle(s) should always be tested for proper functionality prior to plugging the recreation vehicle shore power cord into it.

Campsite 120-volt power receptacles can be tested using a digital multimeter or a dedicated circuit analyzer. Dedicated circuit analyzers plug directly into the campsite power receptacle and minimally test for open neutral, open ground, and correct polarity.

Connecting The Power Cord

Always test the external power source (i.e., the campsite power receptacle or electrical box) with a ground monitor before connecting your power cord to it. If the ground monitor indicates 'reverse polarity' or an 'open ground' **DO NOT** connect the power cord.

To help prevent power surges from damaging the connected loads, please follow these instructions when hooking up to the external power source:

1. Turn off the load center main 120-volt circuit breaker.
2. Carefully extend the entire length of the power cord (approximately 25'-35') from the electric cable hatch to the external power source.
3. Plug the power cord into the receptacle. Be sure all the power cord prongs are properly plugged into the receptacle.
4. Return to your RV and turn on the load center main circuit breaker.

The shore power cord should be unplugged when the recreation vehicle is left unattended.

When you are ready to leave, reverse the power cord connection process. Use care to prevent damaging the power cord electrical connection pins when connecting or disconnecting the shore power cord. Grasp the plug to remove the power cord from the outlet; do not unplug it by pulling on the cord.

Maintenance

Inspect the power cord for cuts, cracks and worn insulation. Have the power cord replaced immediately if these symptoms are noticed.

PROGRESSIVE DYNAMICS INVERTER (IF EQUIPPED)

A factory installed inverter converts 12-volts DC to useable 120-volts AC and supplies AC power to the appliance plugged into it. It is important that you familiarize yourself with the inverter function and operation. The inverter should be “off” when not in use.

NOTE

The inverter is not intended for use, nor should be used, with any medical device(s). The inverter may, however, be used with some CPAP machines, depending on the CPAP model. Consult your CPAP machine’s instruction manual before use to ensure proper operation.

The inverter has a remote display panel which provide many features:

- Power Button: Press to turn on; hold to turn off
- Select Button: Cycles between display states: Input Voltage, Output Voltage, Output Power, Sleep, Error Code (if applicable)
- Power Indicator: Lights up green when the inverter is on
- Fault Indicator: Flashes red when an error has occurred
- Shore Indicator: Lights up yellow when AC input is detected
- Low Battery Warning Indicator: Lights up red when the battery is nearing the end of its charge
- Sleep: Lights automatically dim after 30 seconds



NOTE

Remote display operates exactly the same as the display mounted to the inverter.

Maintenance

There are no customer serviceable parts inside the inverter case and the manufacturer’s warranty will be void if the case has been removed. The inverter cooling fins and the cooling fan should be kept clear of any obstructions.

Refer to the Inverter manufacturers’ manual in your warranty packet for further operating instructions, error codes, changing inverter settings and safety information.



12-VOLT DC SYSTEM

Your motor home lighting is powered by 12-volt electricity. The 12-volt DC system is composed of components that will operate when the following conditions are met:

- The house batteries power all interior and exterior 12-volt components including the lighting fixtures, water pump, 12-volt motors, 12-volt appliances, etc., when the motor home is not connected to a 120-volt power source.
- 12-volt DC power is supplied when the main power switch is 'on'.
- 12-volt power is supplied by the chassis alternator when the chassis engine is running.
- Batteries will be charged as needed when the shore power cord is plugged into an external 120v/240v power source.

12-Volt Fuse Panel

⚠ WARNING ⚠ (See page 38)

The 12-volt fuse panel is labeled to indicate fuse sizes, positions and the components powered. Fuses are located in the load center.

Replacing a Fuse

Before replacing a fuse, always turn off the electrical components protected by it.

1. Disconnect the shore power cord.
2. Inverter should be OFF.
3. Remove the fuse panel cover to check fuses.
4. Pull the fuse straight out of the fuse block.
5. Insert a new fuse of the same specified voltage, amperage rating and type in the original location.

The fuse panel label should be kept permanently affixed to your recreation vehicle. Fuses will not offer complete protection of the electrical system in the event of a power surge or spike.

12-Volt DC Outlet

⚠ WARNING ⚠ (See page 38)

There may be one or more 12-volt DC power outlets in your recreation vehicle. When the 12-volt DC outlet is used as a power source for an electric appliance, make sure the appliance operates on 12-volt DC power and that it consumes less than 60 watts (5 amps) of power.

BATTERIES - LEAD ACID (IF EQUIPPED)

⚠ WARNING ⚠ (See page 38)

House Batteries

Unless a battery has been fully discharged, house auxiliary batteries are normally charged in one of two ways:

- When the power cord is plugged into 120-volt shore power or when the generator is operational, the converter located in the load center will automatically charge the battery with the converter breaker is turned "ON".
- In certain models, the chassis alternator charging system supplies power to the house auxiliary batteries when the engine is running and the chassis batteries are sufficiently charged.

See the Chassis Guide for information on the chassis batteries and the drivetrain electrical system.

The battery voltage for house and auxiliary batteries is typically monitored on one of the selectable touch screens.

A fully charged battery will read 12.65 volts DC with a specific gravity of 1.265 at 80°F (32°C). A battery is considered discharged at 11.89 volts DC or when it has a specific gravity of 1.120 or less. When voltage drops to 11.89 volts, irreversible battery damage can occur.

Dry Camping

House auxiliary and chassis batteries should be fully charged prior to dry camping. When disconnected from 120-volt shore or generator power (i.e., while dry camping or tailgating) all electrically operated appliances and accessories must be used sparingly. During this period these appliances and accessories are being powered by the house auxiliary batteries directly, and/or indirectly through the inverter/charger.

If excessive amounts of power are drawn from the house auxiliary batteries, either as small applied loads over an extended period of time or as high applied loads for a short period of time, they will become deeply discharged. Permanent battery damage will occur after repeated deep discharge cycles.

General Usage Information (Using Estimated Ratings)

12-volt loads drawn from the battery bank(s) while operating 120-volt appliances through the inverter/charger can approach 300 amps on a single inverter/charger equipped motor home, and 700 amps on a dual inverter/charger equipped motor home. Complete battery discharge will occur quickly when inverter/charger loads are applied.

Batteries discharge at a faster rate the deeper they become discharged. To minimize battery discharge:

- When disconnected from 120-volt shore or generator power and not requiring the operation of 120-volt appliances or equipment, turn the inverter OFF.
- Custom configure your inverter's control panel (see the inverter owner's manual) to best meet your power usage profile.

Battery Inspection and Care

Batteries are all sealed AGM types, maintenance free. Check the external condition of the batteries periodically. Look for cracks in the cover and case.

Battery Storage Instructions

To prevent house auxiliary battery discharge when your motor home will not be connected to shore power for extended periods of time, it is recommended you turn “off” the 12-volt battery disconnect switch, or (main power switch in the stepwell), and disconnect each battery bank at the negative battery cable running to the chassis frame.

During storage, it is important to check the voltage of your batteries at least monthly using the inverter/charger remote control panel if the negative battery cables remain connected. Check with a multi-meter when the battery negative cables aren't connected. Re-charge all batteries to 12.65 volts as needed. If you remove the batteries from the motor home, store them in a dry, cool area.

Battery Replacement

If house batteries need to be replaced, only deep cycle batteries of the same size and type should be installed. Refer to the Chassis Guide for information on chassis battery replacement.

Battery Disconnect Solenoid Switch (House Battery Disconnect)

The battery disconnect solenoid switch, or “main power switch,” is located near the entrance door on the front of the passenger’s console. The indicator light will illuminate Red when turned on.



Battery Disconnect Switch

BATTERIES - LITHIUM (IF EQUIPPED)

House Battery

Your motor home is equipped with a nominal 51.2V smart lithium iron phosphate battery. This battery is also equipped with a nominal 12V output.

Unless a battery has been fully discharged, the house battery is normally charged in one of three ways:

- The chassis alternator charging system supplies power to the house battery when the engine is running and the alternator regulator allows a charge (depending on SOC of the battery, temperature, etc.).
- When the power cord is plugged into 120-volt shore power, the converter/charger functions as a battery charger and will automatically charge the house battery when required.
- Power from the solar panels also run through the converter/charger to function as a battery charger/maintainer when required.

Dry Camping

House auxiliary and chassis batteries should be fully charged prior to dry camping. When disconnected from 120-volt shore or generator power (i.e., while dry camping or tailgating) all electrically operated appliances and accessories must be used sparingly. The smart lithium iron phosphate battery capacity is 210AH.

During this period these appliances and accessories are being powered by the house battery directly, and/or indirectly through the inverter/charger. If excessive amounts of power are drawn from the house battery, they will become deeply discharged. Permanent battery damage will occur after repeated deep discharge cycles.

Battery Switches

The Lithium battery is equipped with a Self-Resetting Switch and Self-Locking Switch.

For Long Periods Of Storage

Prior to long periods of storage, it is recommended to turn “off” the Self-Locking Switch and minimize the self-discharge rate when your motor home will not be connected to shore power.

During storage, it is important to check battery voltage at least every two weeks and to recharge them as needed.

- Charge the battery to 50%-70% and turn off the battery with the Self-Locking Switch.

To restart the battery, long press the Self-Resetting Switch for 3-5 seconds. After restarting, the battery will automatically run the self-check program and release the protection mode if the recovery conditions have been reached.

Battery Replacement

NOTE

Battery replacement and maintenance should only be done by a qualified Service Technician.

Do not reverse the positive and negative battery cables. Doing so will blow the reverse polarity fuses that protect the power converter.

For More Information

Contact the battery manufacturer for more information on the house battery. Refer to your Chassis Guide for information pertaining to the chassis batteries.

12-Volt Battery Disconnect

The 12-volt battery disconnect switch is typically located on the cabinet base inside the side sliding door. This momentary switch controls a solenoid which connects or disconnects the 12V output from the house battery. The switch lights up red when turned on. When engaged, the battery disconnect solenoid supplies battery power to all accessories connected to the house 12-volt fuse panel. The solenoid must be engaged for the 12-volt house electrical system to operate.



The battery disconnect feature should be used to disconnect the motor home from 12V house battery power. During periods of storage or during maintenance, turn off the battery with the self-locking switch.

ELECTRICAL

LOAD CENTER

The Load Center contains 12VDC fuses and 120VAC circuit breakers for almost all of the electrical appliances and circuits in the RV. The 120V main breaker may be located in this panel and will turn off all 120-volt power to the RV. Load center location, appearance and configuration may vary by model. Refer to the diagram inside the load center for specific fuse assignments.

Motor homes may have separate small panels for breakers and fuses. They are normally located in close proximity to each other typically in the bed platform. The converter is mounted separately, typically under the bed platform.

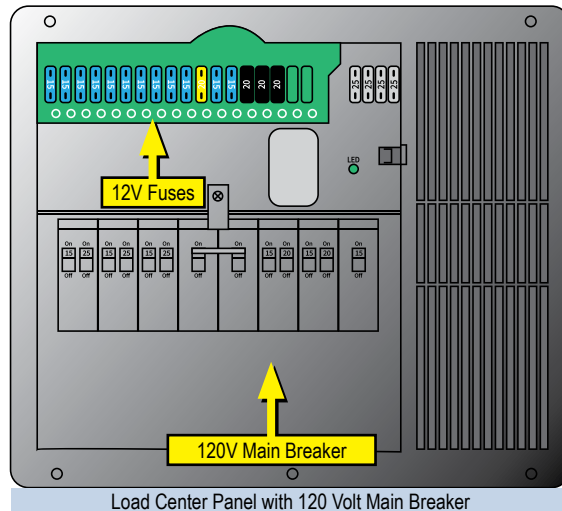
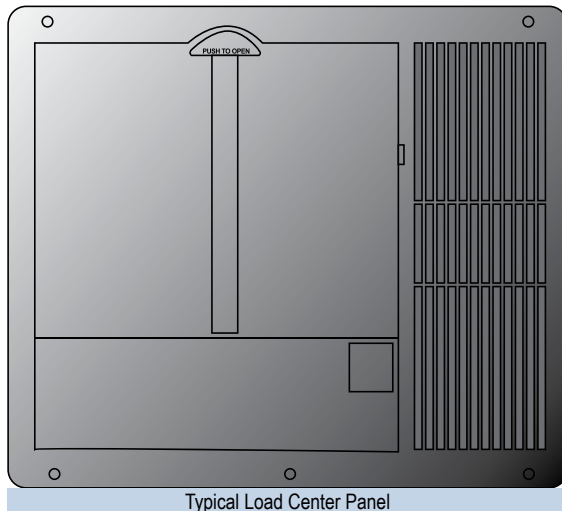

APPROXIMATE ELECTRICAL LOAD RATINGS

12 VOLT SYSTEM	
Exterior Entertainment Center	5-7 AMPS
Fan	1.5 AMPS
Furnace	12.0 AMPS
Generator Start	95.0 AMPS*
Illuminated Switch	.125 AMP
Inverter	variable
Leveling System	95.0 AMPS*
LP Detector	.125 AMP
Light; LED	1.7 AMPS
Light; Vanity	4.2 AMPS
Lights; Aisle	1.0 AMP
Lights; Baggage Compartment / Shower	1.4 AMPS
Lights; Decorative Wall / Map / Porch	1.5 AMPS
Lights; Double -12"	2.0 AMPS
Lights; Double -18"	2.5 AMPS
Power Awning	10.0 AMPS*
Power Vent	5.0 AMPS
Refrigerator (if 12V Refrigerator is equipped)	3.0 AMPS
Step Cover	10.0 AMPS*
TV Plate/Antenna Booster	1.0 AMP
Water Heater	6.0 AMPS
Water Pump	7.0 AMPS

*Momentary Load

12 Volts: Labeled watts divided by 12 = Power consumed in AMPS

120 VOLT SYSTEM	
Air Conditioner	18 AMPS
Coffee Maker	6-12 AMPS
Converter (each)	8 AMPS
DVD System	3 AMPS
Fireplace	15 AMPS
Hair Dryer or Curling Iron	10-14 AMPS
Microwave	15 AMPS
Refrigerator	6 AMPS
Satellite Receiver	2 AMPS
TV	2-4 AMPS
Vacuum Cleaner	8 AMPS
Washer/Dryer	12 AMPS
Water Heater	12 AMPS

*Momentary Load

120 Volts: Labeled watts divided by 120 = Power consumed in AMPS

AUTOMATIC TRANSFER SWITCH (ATS)(IF EQUIPPED)

Your motor home is equipped with an Automatic Transfer Switch with built in reverse polarity protection. The ATS is microprocessor controlled and will automatically detect which power source is being used (generator or shore power) and allow power from that connection only. You will not have to plug and unplug power to the coach if you decide to run the generator.

If you plug into shore power, the ATS will pass power to the motor home. If the generator is started, it will override the shore power input (called generator dominant) and supply the RV with electrical power from the generator. When the generator is shut down, shore power is restored.

If the RV has 120-volt lights and appliances, there may be a slight flicker of the lights when the ATS changes over from one to the other.

The ATS will disconnect from shore power completely if the power coming in is not high enough quality (i.e. either low/high voltage, or low/high frequency).

When the generator is operating, it powers the inverter/charger which in turn functions as a multi-stage battery charger to charge the house auxiliary and chassis batteries.

NOTE

The generator requires 12-volt power from the house auxiliary batteries to start, and draws fuel to operate from the chassis fuel tank. If the fuel level in the chassis fuel tank drops to or below $\frac{1}{4}$ full, the generator will shut "off" and cannot be re-started until the fuel tank is filled to above $\frac{1}{4}$ full. Use the prime function to clear air from the fuel lines.

Refer to and follow safety information found in the manufacturer's troubleshooting guide found in your warranty packet.

GENERATOR (IF EQUIPPED)

⚠ WARNING ⚠ **⚠ CAUTION ⚠** (See page 38) & (See page 38)

Your motor home is equipped with an LP or a fuel powered generator. The generator produces 120/240-volt power compatible with the motor home electrical system. It can power the entire motor home when 120/240-volt shore power is not available.

Before Starting the Generator

1. Make sure the carbon monoxide detector is working.
2. Turn off air conditioners and all other 120-volt appliances.
3. Check for fuel, exhaust and coolant leaks.

STOP the generator immediately if there is a fuel, exhaust or coolant leak. Have all leaks repaired prior to placing the generator back in service.

Transfer Switch

For more information, see the Automatic Transfer Switch (ATS) section.

NOTE

The diesel (or gas) generator requires 12-volt power from the house auxiliary batteries to start, and draws diesel fuel (or gas) to operate from the chassis fuel tank. If the fuel level in the chassis fuel tank drops to or below $\frac{1}{4}$ full, the generator will shut off and cannot be re-started until the fuel tank is filled to above $\frac{1}{4}$ full.

Maintenance

During periods of extended storage:

1. Add a diesel fuel additive to the chassis fuel tank to prevent algae growth (only with a diesel fueled generator).
2. Completely fill the chassis diesel fuel tank to prevent water condensation and rust in the tank (only with a diesel fueled generator).
3. Cover the end of the generator exhaust pipe with screen to prevent bug and rodent intrusion.

With the exception of simple items, such as normal maintenance (i.e., oil changes, etc.), all service work should be done by an authorized repair facility. Improper adjustments can damage the generator and electrical appliances and can result in a safety hazard. **Follow the generator owner's manual for maintenance intervals and recommendations.**

Exercising Your Generator – When storing the generator for extended periods of time, it is important to run the generator regularly to keep it in good working order. Lack of exercise can cause moisture build-up in the fuel system resulting in poor performance.

For more information on generator operation and maintenance, refer to the generator owner's manual.

STARTING THE GENERATOR

Your motor home has a touchscreen to control the generator and Your motor home has a manual switches located either in the door area, the Command Center panel, on the dash, or in an overhead cabinet. The generator may also be controlled via the touch screen (if equipped). There is a secondary switch located on the generator itself. An hour meter that keeps track of generator hours used is located on the touchscreen and a separate hour meter on the generator.

To Manually Start the Generator

1. At either "START/STOP" switch, press and hold the start portion of the switch to start the generator. Depending on the outside temperature the start process can take up to 15 seconds. Once the generator starts running, release the switch.
2. An LED above the start switch will light when the generator is running.
3. For better performance and engine life, especially in colder weather, let the generator engine warm up for two minutes before turning "ON" 120-volt appliances.

For more information on generator operation and maintenance, refer to the manufacturer's owner's manual.

Touchscreen - Automatic Generator Start (AGS)

Your motor home model may be equipped with an Automatic Generator Start system (AGS). The controls are built into the touchscreen system. When enabled, the Automatic Generator Start system will automatically start and stop the generator according to operator or factory pre-selected parameters.

Refer to the AGS Start section or the Touch Screen User Guide (in your warranty packet) will give detailed instructions on the Automatic Generator Start.



SOLAR PREP (IF EQUIPPED)

CAUTION (See page 38)

Your motor home may be equipped with a roof mount solar panel quick connection. This allows a (customer purchased) solar panel to be installed permanently on the roof. Installation will consist of the solar panel(s), regulator and wiring/fusing between the regulator and batteries. There are no other solar plugs for portable solar panels on the vehicle.

The (black ABS) solar prep box is located in a basement compartment of the RV and is marked with a solar prep label (indicating wire colors and polarity). There is also an additional label indicating the RV is wired for solar.

When connected, the solar panel will supply power to the battery and the battery will supply power to all the 12V systems as needed.



Roof Mount

SOLAR PANEL (IF EQUIPPED)

Solar panels produce 12-volt DC electricity when exposed to sunlight. Energy produced by the solar panels is used to charge the house auxiliary and chassis batteries.

Controller

The controller is capable of charging two battery banks – house and chassis. A status LED indicates connectivity of batteries.

Refer to the manufacturer's operation manual in your warranty packet for more detailed information.

Maintenance

Clean the solar panel upper surface regularly using a soft cloth or sponge with water and a mild detergent. Do not use harsh chemicals or abrasive brushes that might damage the panels' upper translucent surface.



ELECTRICAL

SOLAR ENERGY SYSTEM - LITHIUM (IF EQUIPPED)

⚠ DANGER ⚠ ⚠ WARNING ⚠ ⚠ CAUTION ⚠

(See page 37) & (See page 38) & (See page 38)

Your RV may be equipped with a Solar Energy System consisting of Solar Panels, an Inverter and Lithium Battery. In the event of a system issue, there is a high voltage/solar panel disconnect on the roof for emergency usage and a secondary disconnect located near the lithium battery for easier customer access.

Refer to the manufacturer's guide (for each component) for important safety and user information.

The following warning labels have been added to the motor home. These labels should not be removed (appearance may vary slightly).

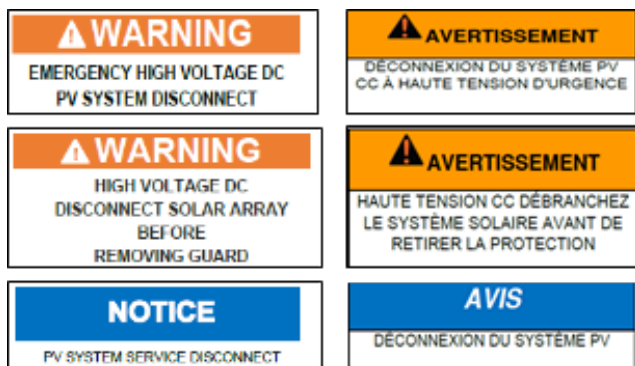

Solar Panels

The energy system should be turned off (using the disconnect switch) before cleaning the solar panels.

Cleaning

Although the Solar Energy System is generally maintenance free, significant performance gains can be made with clean solar panels

- Clean the solar panels monthly. Use water and a soft sponge or cloth. A mild non-abrasive cleanser can be used for more stubborn residue. Rinse well.
- Clean solar panels more frequently during drier months, as they may become covered in dust more quickly. A pressure washer is not recommended.
- Visual inspection – check the exterior for cracks, missing or broken hardware or other potential problems. Check all roof penetrations and replace sealant areas as required

Any maintenance or repairs should only be performed by a Qualified Technician.

NOTE

If your solar panel(s) are covered by snow they will not produce power and can not be depended upon to keep the batteries topped up. In mild climate storage you can depend upon your solar system to top up your batteries when they are exposed to sunlight. Make sure that all parasitic draws are removed from the batteries i.e. clock radio, etc. to make sure the solar panel(s) can keep the batteries topped up even with reduced sun exposure.

POWER SHARE SWITCH

In order to assist with power management, the Power Share Switch will complete the following dependent on floor plan:

- A/C turns OFF when Microwave is turned ON.
- Heater/Water Heater turns OFF when the Microwave is turned ON.
- Heater/Water Heater turns OFF when Induction Cooktop is turned ON.

The Primary appliance never losses power. The Secondary appliance is allowed to run as long as the Primary is not drawing current. Power to the Secondary appliance is turned off whenever the Primary Appliance is drawing current. The decals for the circuit breakers will have the combination clearly labeled.

HIGH IDLE START STOP - SPRINTER CHASSIS (IF EQUIPPED)

Your unit is pre-wired for a future High Idle Start Stop System shall you choose to install an aftermarket system. The Pre-wire includes a Red Wire (start signal) and Green wire (stop signal). These wires will connect to the aftermarket system to the Firefly System.

The Firefly Touchscreen has an Auto Engine Start (AES) option which will provide a set of triggers and the engine can be manually started or stopped with the High Idle Start Stop System activated. Your Firefly Manual will have a complete overview of the AES Settings and how to turn on the AES option.

It is the responsibility for the owner to complete the installation of the aftermarket High Idle Start Stop system and following the aftermarket suggested requirements for operation. When leaving the vehicle, it is the user's responsibility to ensure that the vehicle is in a safe location to start remotely. If the vehicle is indoors or any other location where it should not be running, it is the user's responsibility to ensure that the system is not activated.

As the owner, you will assume all responsibility against Mercedes Sprinter OEM Warranty.

HIGH IDLE START STOP - PROMASTER CHASSIS (IF EQUIPPED)

Your unit is built with an engine start/stop system designed for the Dodge Promaster chassis. It will automatically start and stop the vehicle's engine (when enabled) to charge OEM 12V battery and/or the lithium battery.

The system is connected to the Firefly touchscreen which has an Auto Engine Start (AES) page. It will provide a set of triggers and the engine can be manually started or stopped with the High Idle Start Stop System enabled. Your Firefly Manual will have a complete overview of the AES Settings.

In order for the system to operate, it must first be in "Monitor Mode". If preconditions (below) are met, this mode can be entered by pushing and holding the Monitor Mode control. The preconditions for entering Monitor Mode are:

- Vehicle in Park
- Parking Brake applied
- Hood Closed
- Fuel Level above 1/4 tank

ELECTRICAL

- Key Fob near steering wheel and unit in the RUN position
- Engine coolant temperature is within acceptable range (not too hot or cold)

If preconditions are met and Monitor Mode is entered, the control button LED turns ON as a visual indication. As long as Monitor Mode is active, the LED remains ON continuously. The ignition can be set to off after entering Monitor Mode.

While in Monitor Mode, the system will continue to review the system. System parameters include:

- Primary OEM 12V battery (System starts a 12.0V and go back to Monitor Mode at 13.5V)
- Engine Coolant Temperature (System shutdown at 230°F)
- High Idle Engine Speed will idle at 1500 RPM
- Maximum engine run time is set at 2 hours.
- Monitor Mode Lockdown Time is set at 5 minutes.

NOTE

When in Monitor Mode, a temporary lockout occurs if service brake is applied, disabling auto start/stop.

- Engine Coolant Temperature

Exiting Monitor Mode is accomplished by pushing the Monitor Mode control button.

It is the responsibility of the vehicle operator to ensure their vehicle is parked in a safe and responsible manner.

- When leaving the vehicle, it is the user's responsibility to ensure that the vehicle is in a safe location to start remotely. If the vehicle is indoors or any other location where it should not be running, it is the user's responsibility to ensure that the system is disabled (remote start off) before leaving the vehicle.
- It is the user's responsibility to ensure that the remote starter is disabled before servicing.

Current operation setup would require the user to be present while enabled or engine running in order to secure the vehicle. If you should decide that you want to leave your vehicle unintended with the system is activated. It will require modifying one of your key fobs or purchasing an additional key fob to be left in the vehicle. There is a key fob box installed behind the center console for future usage.

A spare key fob pre-programmed for the vehicle will need to be modified and inserted into the provided enclosure which has been mounted behind the center console. It will allow the system to work with the key fob outside of the vehicle.

Steps For Modifying The Key Fob:

1. Remove the physical key from the key fob.
2. Separate the key fob using a small flat head screwdriver.
3. Remove the battery from the key fob.
4. Remove the RAM sticker from the back of the key fob.



5. Place the bottom half of the key fob in the key fob jig.
6. Flip the key fob and jig upside down and drill a hole through the back of the key fob using a 0.5" drill bit.



7. Place the battery PCB board in the key fob as shown.
8. Snap both halves of the key fob back together. Ensure that the connector on the opposite side of the battery board is centered in the middle of the hole.



Steps For Inserting Into The Key Fob Box:

1. Remove the cup holder from the center panel console below the shifter.
2. Locate the key fob mounted with Velcro.
3. Disconnect the harness and remove.



4. Place the key fob in the bottom half of the key box installed on the center console removed.
5. Plug the 2-pin White connector into the battery board and route the harness toward the hole in the side of the box. Place the rubber grommet in the hole as shown.
6. Place the top portion of the box on top and secure it with the 4 included screws.
7. Re-connect the 3 pin connector into the mating connector on the main harness.



ELECTRICAL

HIGH IDLE START STOP - TRANSIT CHASSIS (IF EQUIPPED)

Your unit is built with an engine start/stop system designed for the Ford Transit chassis. It will automatically start and stop the vehicle's engine (when enabled) to charge OEM 12V battery and/or the lithium battery.

The system is connected to the Firefly touchscreen which has an Auto Engine Start (AES) page. It will provide a set of triggers and the engine can be manually started or stopped with the High Idle Start Stop System enabled. Your Firefly Manual will have a complete overview of the AES Settings.

In order for the system to operate, it must first be in "Monitor Mode". If preconditions (below) are met, this mode can be entered by pushing and holding the Monitor Mode control. The preconditions for entering Monitor Mode are:

- Vehicle in Park
- Parking Brake applied
- Hood Closed
- Fuel Level above 1/4 tank
- Key in the ignition and unit in the RUN position
- Engine coolant temperature is within acceptable range (not too hot or cold)

If preconditions are met and Monitor Mode is entered, the control button LED turns ON as a visual indication. As long as Monitor Mode is active, the LED remains ON continuously. The ignition can be set to off after entering Monitor Mode.

While in Monitor Mode, the system will continue to review the system. System parameters include:

- Primary OEM 12V battery (System starts a 12.0V and go back to Monitor Mode at 13.5V)
- Engine Coolant Temperature (System shutdown at 230°F)
- High Idle Engine Speed will idle at 1500 RPM
- Maximum engine run time is set at 2 hours.
- Monitor Mode Lockdown Time is set at 5 minutes.

NOTE

When in Monitor Mode, a temporary lockout occurs if service brake is applied, disabling auto start/stop.

- Engine Coolant Temperature

Exiting Monitor Mode is accomplished by pushing the Monitor Mode control button.

It is the responsibility of the vehicle operator to ensure their vehicle is parked in a safe and responsible manner.

- When leaving the vehicle, it is the user's responsibility to ensure that the vehicle is in a safe location to start remotely. If the vehicle is indoors or any other location where it should not be running, it is the user's responsibility to ensure that the system is disabled (remote start off) before leaving the vehicle.

- It is the user's responsibility to ensure that the remote starter is disabled before servicing.

Current operation setup would require the user to be present while enabled or engine running in order to secure the vehicle. If you should decide that you want to leave your vehicle unintended with the system is activated. It will require modifying one of your key fobs or purchasing an additional key fob to be left in the vehicle. There is a key fob box installed on the lower driver kick panel behind the hood latch for future usage.

A spare key fob pre-programmed for the vehicle will need to be modified and inserted into the provided enclosure which has been mounted behind the center console. It will allow the system to work with the key fob outside of the vehicle.

Steps For Modifying The Key Fob:

1. Push the silver button so that the key is flipped out.
2. Rotate the Fob so that the Ford logo faces up. Stick a flat head screwdriver into the slots and use the leverage of the screwdriver to pop off the back cover (as shown below).
3. Remove the star screw highlighted in the picture below using a T6 Torx (star) screwdriver.



4. Gently pry apart the two halves of the Fob. We found this is most accomplished by inserting a pair of needle nose pliers into the Fob and slowly open up the pliers.
5. Remove the silver loop from the back, the switchblade key, and the battery.
6. Reassemble the key Fob.

Steps For Inserting Into The Key Fob Box:

1. Remove the key fob box from behind the hood release latch



on the lower left kick panel.

2. Remove the cover on the back side of the key fob box and insert the key fob into the key fob ring.
3. Insert the key fob into the bottom of the key fob box and route the harness toward the hole in the side of the box. Place the rubber grommet into the hole.
4. Replace the cover plate and secure it with the (4) fasteners previously removed.



**SOLAR ENERGY SYSTEM (See page 34)**

- Danger of electric shock! Make sure that all power supplies on solar inverter disconnected and that all capacitive power is released before checking or operating accordingly!
- **The Solar Energy System is a HIGH VOLTAGE SYSTEM and should only be serviced by a Qualified Technician.**

Failure to follow these guidelines may result in serious injury or death.

**TESTING CAMPSITE POWER (See page 27)**

Do not hook the power cord to any receptacle until you have verified proper polarity and grounding.

DO NOT plug the shore power cord into a campsite receptacle(s):

- That has reverse polarity
- That has non-functioning ground circuits
- That shows outward signs of heat damage.

Doing so may result in property damage or serious injury. Plugging the shore power cord into an incorrectly wired power source could damage the recreation vehicle electrical system and result in severe or fatal injury. Damage or injury resulting from connection to malfunctioning or improperly wired power sources is not covered by your recreation vehicle warranty.

DO NOT

- Do not use any cheater plug, adapter or extension cord to reconfigure incoming AC power or break the continuity of the circuit connected to the grounding pin.
- Do not connect the power cord into an outlet that is not grounded, or adapt the power cord plug to connect it to a receptacle for which it is not designed.
- Do not remove the grounding pin to connect to a non-grounded receptacle. Removal of the ground pin disables an important safety feature designed to prevent shock and electrocution hazards.
- Do not connect the power cord to an extension cord. Use of an improper extension cord will cause overheating of the cord as well as potentially causing premature failure of the AC equipment.
- The power cord must be fully extended when in use and not left coiled in the electrical compartment or on the ground. A power cord left coiled may potentially create enough heat to melt its protective casing.

It is the responsibility of the owner of the electrical receptacle to ensure that the receptacle is properly wired and grounded. **Reverse polarity and/or improper grounding of your RV can cause property damage or serious personal injury.**

BATTERIES (page 27)

- **Do not store anything inside the battery compartment(s)** or near the batteries that could touch the battery or battery cable terminals. Contact with the battery or battery cable terminals could cause an electrical short circuit, discharge the batteries, or start an electrical fire.
- **Keep sparks, cigarettes and flames away from the batteries as the hydrogen gas they create may explode.** Do not connect a booster battery or other power source that outputs more than 14.2-volts DC to the RV batteries. Use adequate ventilation when charging or using batteries in an enclosed space.
- Remove metal jewelry and always wear eye protection when working around batteries.
- **Do not allow battery electrolyte (acid) to come into contact with skin, eyes, fabric or painted surfaces.** Electrolyte is a sulfuric acid solution that could cause serious personal injury or property damage. If your hands, eyes, clothes or the painted surface of your RV are exposed to electrolyte, flush the exposed area thoroughly with water. If electrolyte gets in your eyes, immediately flush them thoroughly with water and get prompt medical attention.
- **Make sure the inverter/charger is turned “off” before disconnecting the negative battery cable from the battery bank.** Keep the batteries out of the reach of children.

REPLACEMENT - CIRCUIT BREAKER (page 25)

Replacement circuit breakers must be of the same voltage, amperage rating and type. Never use a higher rated replacement circuit breaker; doing so may cause a fire by overheating the RV wiring.

**GENERATOR (See page 32)**

CARBON MONOXIDE IS DEADLY! Do not run the generator when your motor home is indoors or in a confined space.

DO NOT use the AGS AUTO ON or QUIET ON modes (if so equipped) when your motor home is indoors or in a confined space.

Asphyxiation or carbon monoxide poisoning hazards exist whenever generator exhaust gasses can accumulate.

MOVING PARTS AND ELECTRICITY can cause severe personal injury or death. To reduce exposure to these hazards, **always disable AGS (if so equipped) before:**

- Sleeping in vehicle, unless vehicle has a working CARBON MONOXIDE detector.
- Parking vehicle in garage or confined space.
- Parking vehicle for storage.
- Servicing vehicle for storage.
- Servicing generator.
- Servicing batteries.
- Servicing appliances or electrical systems.
- Fueling the vehicle.

12-VOLT DC OUTLET (See page 29)

Keep the protective dust cap on the 12-volt DC outlet when not in use to prevent intrusion of foreign material and potential short circuit conditions.

12-VOLT FUSE PANEL (See page 29)

Replacement fuses must be of the same voltage, amperage rating and type. **Never use a higher rated replacement fuse;** doing so may cause a fire by overheating the RV wiring.

ELECTRICAL SYSTEM ((See page 26)

Use caution when using metal tools. If a tool contacts a battery terminal or metal connected to it, a short circuit could occur which could cause personal injury, explosion or fire.

SOLAR ENERGY SYSTEM (page 42)

You should not attempt to remove the battery yourself. **The Solar Energy System is a HIGH VOLTAGE SYSTEM and should only be serviced by a Qualified Technician.**

Failure to follow these guidelines may result in serious injury or death.

- The components are not serviceable and the system should only be inspected or repaired by a Qualified Service Technician.
- The energy system should be turned off (using the disconnect switch) before checking any component.

Failure to follow these guidelines may result in serious injury or death.

**GENERATOR (See page 32)**

Excessive usage can overheat and damage the generator starter motor. Do not engage the starter motor for more than 20 seconds at a time. If the generator does not start after the first attempt, wait at least two minutes before beginning another start sequence. If the generator does not start after a third attempt, refer to the generator owner's manual for additional information.

SOLAR PREP (See page 33)

Adding additional solar panels or equipment will affect the carrying capacity of the motor home. Vehicle weight ratings should be considered before adding these components.

SOLAR ENERGY SYSTEM (See page 34)

Adding additional solar panels or equipment will affect the carrying capacity of the motor home. Vehicle weight ratings should be considered before adding these components.

SECTION 6: FUEL & PROPANE SYSTEM



EXHAUST GAS FUMES

⚠ WARNING ⚠ (See page 43)

To avoid breathing exhaust gases, follow these precautions:

- Do not run the engine in confined areas, such as a closed garage, any longer than needed to move your motor home in or out of the area.
- Windows should be closed while driving or running the generator (if so equipped) to avoid drawing dangerous exhaust gases into the motor home.
- If you suspect that exhaust fumes are entering the passenger compartment, have the cause determined and corrected as soon as possible.

If you must drive under these circumstances, close all the windows, and adjust the heating or cooling system to force outside air into the motor home (set the blower on high speed).

The best protection against carbon monoxide entry into the motor home is a properly maintained ventilation system and an active carbon monoxide detector. To allow for proper operation of the motor home ventilation system, keep the ventilation inlet grill(s) clear of snow, leaves or other obstructions at all times.

Maintenance

It is recommended that the exhaust system and vehicle body be inspected by a qualified motor home service center:

- Each time the engine is ready for an oil change.
- Whenever a change in the sound of the exhaust is noticed.
- Whenever the exhaust system, underbody or rear of the vehicle is damaged.

For more information refer to your Chassis Guide.

FUEL SAFETY

⚠ DANGER ⚠ (See page 42)

Fuel Selection

Some generators (if equipped) are fueled by the same system used to fuel the chassis engine. Check the generator manufacturer and the chassis manufacturer information to help determine the type of fuel best suited for this dual application.

Fuel Fill Cap

⚠ WARNING ⚠ (See page 43)

Remove the fuel fill cap by slowly turning it counterclockwise, waiting for any “hiss” noise to stop, and then unscrew the cap all the way. To close the fuel fill cap, securely turn the cap clockwise until you hear clicking sounds.

Filling The Fuel Tank

⚠ DANGER ⚠ (See page 43)

Use care when fueling your motor home. If you spill fuel on the motor home, clean it up immediately. Fuel can dull or soften paint and damage other surfaces.

PROPANE GAS SYSTEM (IF EQUIPPED)

⚠ WARNING ⚠ (See page 43)

Propane or LP (liquefied petroleum) gas is an efficient form of energy when proper handling and safety precautions are observed. The propane system in your motor home furnishes the fuel for cooking, heating, hot water and can be an alternative energy source for refrigeration. Propane is heavier than air and tends to flow to lower areas and will sometimes pocket in these low areas, such as the floor. Your motor home is equipped with a propane alarm (refer to *Safety Precautions, Combination Carbon Monoxide (CO)/Propane Alarm*).

FUEL & PROPANE SYSTEM

The propane fuel system is comprised of numerous components such as the propane container, hoses, propane gas regulator, piping and copper tubing to each appliance.

Your motor home has been carefully tested at the factory and by your selling dealer for leakage. Travel vibrations can loosen fittings. Have the vehicle propane system checked at all connections soon after the purchase of your vehicle, and after the initial filling of the propane tanks.

Continued periodic checks of the propane system at 5,000 miles of travel (or at least once a year) by a qualified propane service representative as part of your normal maintenance is recommended. Hand tighten the LP gas system valves only, do not use a wrench or pliers as over tightening may damage the valve seals and cause them to leak.

NOTE

All propane lines have been checked with air pressure at the time of manufacture. Dealers are required to recheck and adjust pressure before retail delivery.

The following label should be kept permanently affixed to the motor home:

! DANGER

ALL PILOT LIGHTS, APPLIANCES, AND THEIR IGNITORS (SEE OPERATING INSTRUCTIONS) SHALL BE TURNED OFF BEFORE REFUELING OF MOTOR FUEL TANKS AND/ OR PROPANE CONTAINERS.
FAILURE TO COMPLY COULD RESULT IN DEATH OR SERIOUS INJURY.

! WARNING

DO NOT FILL PROPANE CONTAINER(S) TO MORE THAN 80 PERCENT OF CAPACITY.
FAILURE TO COMPLY COULD RESULT IN DEATH OR SERIOUS INJURY.

! CAUTION

THIS PIPING SYSTEM IS DESIGNED FOR USE WITH PROPANE ONLY. DO NOT CONNECT NATURAL GAS TO THIS SYSTEM.

Securely cap this inlet when not connected for use. After turning on propane, except after normal cylinder replacement, test propane piping and connection to appliances for leakage with soapy water or bubble solution. Do not use products that contain ammonia or chorine. DD-37

Propane Label

Propane Gas Container

Propane is a true gas compressed into a liquid form. As the fuel is released from the container, it changes to vapor which is then used for the operation of the appliances. Propane will not run through the appliances in the liquid state.

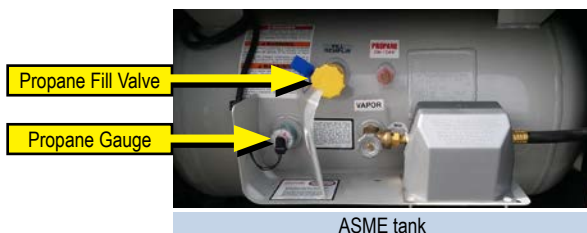

ASME tank

A permanently mounted A.S.M.E. approved propane container is located under the floor of the motor home.

NOTE

Tanks are to be installed, fueled and maintained in accordance to State and Local codes, rules, regulations or laws.

Propane expands 1½ percent for every ten degrees of increase in temperature. It is imperative to leave sufficient space inside the container to allow for natural expansion of gas during warmer weather.

Servicing or Filling

! WARNING ! (See page 43)

Because the container is not removable, the motor home will need to be driven to a qualified propane facility for servicing or filling.

Only the authorized gas service technician(s) should be near the motor home while the propane tank is being filled. The new propane container must be carefully purged for proper appliance performance and operation. The propane tank must NEVER BE OVERFILLED.

Replace all protective covers and caps on the propane system and/or container after filling. Make sure the valve is closed and the compartment door is securely latched.

LP Gas Container Overfill

Never allow your propane tank to be filled above the maximum safe level as indicated by the fixed liquid level gauge.

Do not allow the visible gauge to be used for filling. Overfilling the propane container above the liquid capacity indicated on the container, could allow liquid propane to enter the system that is designed for vapor only creating a hazardous condition.

The following warning label has been placed by the propane container.

! WARNING

DO NOT FILL CONTAINER(S) TO MORE THAN 80 PERCENT OF CAPACITY.
FAILURE TO COMPLY COULD RESULT IN DEATH OR SERIOUS INJURY.
OVERFILLING THE PROPANE CONTAINER CAN RESULT IN UNCONTROLLED PROPANE FLOW, WHICH CAN CAUSE FIRE OR EXPLOSION.
A PROPERLY FILLED CONTAINER CONTAINS APPROXIMATELY 80 PERCENT OF ITS VOLUME AS LIQUID PROPANE.

Propane System Label

Refer to your Warranty Packet for more information on the LP gas system components.

Propane Regulator

NOTE

Regulator appearance and type may vary by model.

Single stage regulator

Some models are equipped with a single stage regulator.

Two stage regulator

The two-stage regulator has the only moving components in the propane system. Its sole function is to reduce the pressure from the propane containers to a safe and consistent low operating pressure. The first stage reduces the container pressure to 10-13 lbs. The second stage reduces the 10-13 lbs. of pressure further to an

operating pressure of 11" W.C. (water column) or 6.35 oz. of outlet pressure to your appliances.

The second stage is adjustable and will need to be adjusted by your dealer or qualified propane service technician for optimum performance (this adjustment should always be made with a properly calibrated manometer).

If the pressure is too high, it affects performance and safety; if the pressure is too low, your appliances will not operate correctly.

If your recreation vehicle is equipped with the "automatic" two-stage regulator, with both cylinders full of propane, turn the lever on the regulator towards the cylinder you wish to use first. This will be the "supply" cylinder and the other the "reserve". Slowly open both cylinder valves. The indicator on top of the regulator will turn bright green. When the cylinder becomes empty, the indicator will change to bright orange. Turn the regulator lever to the side of the "reserve" cylinder and the green signal should return. You may now remove the empty cylinder to have it refilled without interrupting the flow from the full bottle. After filling the cylinder, connect the pigtail hose and slowly open the bottle valve.

Refer to the manufacturer's pamphlet included in your warranty packet and follow all safety instructions and warnings listed.

Propane Gas Container (If Equipped)

⚠️ WARNING ⚠️ (See page 43)

DOT propane cylinders used on RVs must be removed for filling and filled by weight at a qualified propane facility. Equipped with an overfill protection device (OPD), they must be oriented correctly, with markings indicating the top position. After filling, securely reinstall the cylinders, close the service valve, and use a dust cap or plug for transportation or storage.

Propane, compressed into a liquid, vaporizes when released for appliance use. It expands with temperature increase, requiring space inside the container for expansion during warmer weather. Keep the main shut-off valve closed except during system use or cylinder filling. Hand-tighten the valve to avoid damaging the interior seals. Leaks should be checked after initial filling and periodically thereafter. When filling a new cylinder, ensure it's purged of trapped air to enable proper appliance ignition.



PROPANE USE AND SAFETY (IF EQUIPPED)

Propane is a colorless and odorless gas that, in the liquefied state, resembles water. An odorant (usually a sulfur compound) is added as a warning agent. If you smell propane within the vehicle, quickly and carefully perform the procedure listed on the propane system label. This label has been placed in the vehicle near the range for models equipped with a propane system.

When a propane container is low, there may be a concentration of an onion or garlic-like odor, which can be mistaken for a propane gas leak. After the propane container has been refueled, the odor will usually disappear. If not, turn off the valve(s) and have the propane system inspected by your dealer or qualified propane service representative.

Propane Leak Test

⚠️ DANGER ⚠️ (See page 43)

Leaks may be found easily with a soapy water solution. Do not use a solution containing ammonia or chlorine when locating leaks. These products are corrosive to copper gas lines and brass fittings, which could result in deterioration of the copper and brass components. Apply the soapy solution to the outside of the gas piping fittings. If a leak is present, the soapy solution will "bubble" at the leak point. If a leak is indicated, shut off the propane system valve(s) and contact your dealer or qualified propane service representative immediately.

Using the Propane System

Use the following steps for propane operation:

1. Close ALL burner valves, controls and pilot light valves.
2. Open the main valve in the propane tank slowly to avoid a rush of propane vapor through the excess flow valve, causing propane "freeze-up." Should you experience propane "freeze-up", close the main valve and wait 15 minutes before trying again.
3. Listen carefully as propane begins to flow. If a hissing noise is heard for more than one or two seconds, close the main valve and contact your dealer to have the propane system tested.
4. Light the appliances as needed and directed in the appliance manufacturer's owner manual located in the Warranty Packet.

Keep the propane container valves closed at all times unless you are using the propane gas system or are having the propane container filled.

Make sure that you read and fully understand ALL safety requirements for handling and operation of the propane system.

The propane system must be handled with care. If you have any questions or concerns, consult with your dealer and/or the specific appliance manufacturer.

If you have double cylinders on your recreation vehicle, use only one at a time. Otherwise, the propane supply will be drawn equally from both cylinders until the supply has been totally exhausted. Using one

⚠️ DANGER

IF YOU SMELL PROPANE

1. Extinguish any open flames, pilot lights and all smoking materials.
2. Shut off the propane supply at the container valve(s) or propane supply connection.
3. Do not touch electrical switches.
4. Open doors and other ventilating openings.
5. Leave the area until odor clears.
6. Have the propane system checked and leakage source corrected before using again.

Ignition of flammable vapors could lead to a fire or explosion and result death of serious injury.

Propane System Label

FUEL & PROPANE SYSTEM

cylinder until it is empty and then using the second cylinder will allow you to fill the empty cylinder at your convenience without running out of propane.

Cooking With Propane Gas

⚠ WARNING ⚠ (See page 43)

Unlike homes, the amount of oxygen supply is limited due to the size of the recreation vehicle. Proper ventilation when using the cooking appliance(s) will help avoid the danger of asphyxiation.

It is especially important that cooking appliances not be used for comfort heating, as the danger of asphyxiation is greater when the appliance is used for long periods of time. **FAILURE TO COMPLY MAY RESULT IN DEATH OR SERIOUS INJURY.**

These warning labels are located in the cooking area to remind the user to provide an adequate supply of fresh air for combustion.

⚠ DANGER

Do not use gas cooking appliances for comfort heating. Can lead to carbon monoxide poisoning, which can lead to death or serious injury.

⚠ WARNING

Gas cooking appliances need fresh air for safe operation. Before operating: Open vents or windows slightly or turn on exhaust fans prior to using cooking appliance. Gas flames consume oxygen, which should be replaced to ensure proper combustion. Improper use can result in death or serious injury.

Cooking / Comfort Heating Label

TO ENSURE A SUPPLY OF FRESH AIR TO OCCUPANTS, OPEN VENTILATORS WHEN FUEL BURNING RANGE, FUEL BURNING CARRY-ON APPLIANCE, AND/OR FUEL BURNING LIGHTS ARE IN OPERATION. COOKING APPLIANCES SHOULD NOT BE USED FOR SPACE HEATING PURPOSES.

DE MANIÈRE À ASSURER UNE ALIMENTATION EN AIR FRAIS AUX OCCUPANTS, OUVRIR LES VENTILATEURS LORSQUE LA CUISINIÈRE, LES APPAREILS DE CHAUFFAGE PORTABLES ET/OU LES LAMPES DE COMBUSTION D'HUILE SONT EN FONCTIONNEMENT. LES APPAREILS DE CUISSON NE DOIVENT PAS SERVIR AU CHAUFFAGE DES LOCAUX.

JA-110

Ensure a Supply of Fresh Air Label (Canada Units Only)

Calculating Propane Gas Usage

Most RV gas appliances are operated intermittently, and each has a different BTU rating. You will need to consider this when planning your propane supply and consumption. Unless there is heavy use of hot water, the water heater consumption of propane is minimal. During cool temperature or high wind conditions, furnace consumption can be extremely high.

To calculate your propane supply, take the BTU ratings for your propane appliances and divide that into the BTU availability. Each gallon of propane gas (3.785 liters) produces about 91,500 BTU's (96,528 kilojoules) of heat energy.

Propane Consumption Chart

The following chart provides average propane consumption information.

Appliance	Average BTU Consumption per Hour	Kilojoules/Hour
Water Heater	8,800	9,280
Refrigerator	1,200 – 1,500	1,270 – 1,580
Furnace	35,000 – 40,000	36,930 – 42,200
Range/oven	7,100	7,490
Range, rear burner	6,500	6,860
Range, front burner	9,000	9,490
Outside Grill	10,000	10,550

Traveling with Propane

⚠ DANGER ⚠ (See page 43)

NOTE

Some states prohibit propane appliance operation during travel, especially in underground tunnels. Know the laws for the areas where you travel.

Use care when fueling your motor fuel tanks and/or propane containers. Ensure your propane tank is properly fastened in place.



FUEL & PROPANE SYSTEM DANGER

FUEL SAFETY (See page 39)

Automotive fuels can cause serious injury or death if misused or mishandled. If you have further questions, consult your dealer or Customer Service for assistance.

- Always shut OFF the vehicle engine while refueling.
- Do not bring or store fuel or other flammable liquids inside the motor home as a fire or explosion may result.
- Before refueling, extinguish all smoking materials and any open flames.
- Before refueling, always turn OFF all spark producing appliances (i.e., water heaters, furnaces, etc.).
- Do not overfill the fuel tank(s). The pressure in an overfilled fuel tank may cause leakage and lead to fuel spray and/or fire.
- Fuel spills represent a serious fire hazard, and should be cleaned up immediately.
- Never restart an engine or re-light any pilot lights while raw fuel is present.

FAILURE TO COMPLY COULD RESULT IN FIRE, DEATH OR SERIOUS INJURY.



FILLING THE FUEL TANK (See page 39)

TRAVELING WITH PROPANE (See page 42)

- All pilot lights, appliances and their igniters (see operating instructions) should be turned off before refueling of motor fuel tanks.
- These can cause ignition of flammable vapors, which can lead to a fire or explosion.
- **FAILURE TO COMPLY COULD RESULT IN FIRE, DEATH OR SERIOUS INJURY.**

PROPANE LEAK TEST (See page 41)

Never use an open flame to test for a propane leak. Do not check for leaks using products that contain ammonia or chlorine as these products can cause cracks to form on the metal tubing and brass fittings.



FUEL & PROPANE SYSTEM WARNING

EXHAUST GAS FUMES (See page 39)

- Avoid inhaling exhaust gases as they contain carbon monoxide, which is a potentially toxic gas that is colorless and odorless.
- If you are in a parked motor home with either the engine running or a generator running there is a potential for exhaust fumes to filter back into the motor home.

FUEL FILL CAP (See page 39)

Do not replace the fuel fill cap with one of a different type. Only use a cap specified for your motor home. Use of a substitute cap may create excessive fuel system pressure, resulting in fuel station damage and improper operation in a collision.

PROPANE GAS SYSTEM (See page 39)

Propane cylinders should not be placed or stored inside the vehicle. LP-gas cylinders are equipped with safety devices that relieve pressure by discharging gas into the atmosphere.

SERVICING OR FILLING (See page 40)

- **Always shut OFF the engine while refueling.** Do not smoke and do not operate other ignition sources while refueling.
- **When the propane container is disconnected from the main supply hose and the P.O.L. connection, install the P.O.L. plastic cap that is attached to the container.**
- **If you suspect your propane container has been overfilled, contact your dealer or a qualified propane technician for assistance immediately.** Do not attempt to service a propane container overfill yourself.

COOKING WITH PROPANE GAS (See page 42)

- Do not turn gas range burner controls to ON and allow gas to escape before lighting.
- Do not use portable fuel burning equipment (i.e., wood and charcoal grills or stoves) inside the recreation vehicle.

PROPANE GAS CONTAINER ((See page 43)

Transport and store DOT propane cylinders upright to ensure proper functioning of the pressure relief device; laying them on their side can be dangerous. Install the pigtail hose to prevent tension or pulling stress, and keep it away from sharp edges and compartment structures. Before entering a propane or fuel service station, extinguish all pilot lights, shut off gas to all appliances, and turn off any engines. Refrain from smoking or operating ignition sources while refueling. If you suspect overfilling of your propane container, seek assistance from your dealer or a qualified propane technician immediately; do not attempt to address it yourself.

SECTION 7: PLUMBING SYSTEM



PLUMBING SYSTEM

There are two different water systems in your recreation vehicle:

- The fresh water system consists of the fresh water holding tank, faucets and connections, water pump, water heater, tub/shower. On some models, it may also include the water purification system or outside shower assembly (if equipped).
- Depending on your model, the waste water system consists of the wastewater and sewage holding tank(s), drains and toilet. Models with a cassette toilet will only have the wastewater system.

Plumbing System Maintenance

- Check all fittings, pressure and waste, for leaks before each trip or before vehicle storage as part of your normal maintenance:
- Inspect all faucets, the water purification system (if equipped) and sink connections (including drain baskets or filters).
- Inspect connections at the water pump and water heater (if equipped).
- At the end of every trip, you should drain any unused water from the fresh water system.

Typically, there are labels affixed to the exterior of the recreation vehicle sidewall that indicate the locations of the water system drains and fills. Be aware some drain valves may be located inside the vehicle (once the exterior label is found, go inside to find the drain corresponding location).

Refer to the manufacturer's operating manual included in your warranty packet for the detailed operating, sanitizing, and winterizing information for each water system component.

FRESH WATER SYSTEM

⚠ WARNING ⚠ (See page 59)

All water contains contaminant and mineral particles that can cause fresh water system odors. Untreated well water is a major source of water system odors. The fresh water (potable water) system needs periodic sanitization to take care of all the components in the plumbing system to discourage the growth of bacteria and other organisms that can contaminate the water supply.

Do not remove the potable water label from your recreation vehicle.

You should use a non-toxic drinking water hose dedicated only to supplying the recreation vehicle with fresh water. To reduce the chance of contamination, prevent the non-toxic drinking water hose from coming into contact with the ground.

⚠ WARNING

POTABLE WATER ONLY. SANITIZE, FLUSH AND DRAIN BEFORE USING. SEE INSTRUCTION MANUAL. FAILURE TO COMPLY COULD RESULT IN DEATH OR SERIOUS INJURY.

AD-04

Potable Water Label

NOTE

If needed, sanitize the water system prior to travel.

Water Pressure Regulator (customer supplied)

⚠ CAUTION ⚠ (See page 57)

Excessive pressure from the water supply source may be encountered in some parks, especially in mountain regions when using the fresh water inlet or black tank flush. Water pressure regulators are available to protect your recreational vehicles plumbing system against such high pressure.

Fresh Water Holding Tank

CAUTION (See page 57)

There may be several ways to fill the fresh water tank depending on the model. For details of each method, refer to the *Utility Center or Water Connection* section. There are plastic overflow tubes in the fresh water holding tank which allow water to flow out of the water tank. Occasionally, you may see water coming from the overflow tubes when the fresh water holding tank is filled. This is normal and can be a result of the recreation vehicle being parked on an incline, or the motion caused by starting or stopping during travel.

12-Volt Water Pump

There must be sufficient 12-volt DC power to run the water pump when your recreation vehicle is not hooked up to city water. Once activated, the water pump (also known as the demand pump) will self-prime, and provide water. The water pump continues to run until maximum pressure is achieved and shut off. The water pump will automatically re-start when it senses a drop in the water pressure. The pump is designed for **intermittent use only**. Using the pump continuously or with high pressure will shorten the life of the pump and is not covered in your warranty.

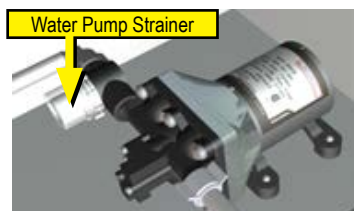

Some cycling may occur, depending on the volume of water being released. The water pump is engineered with a check valve to prevent water from back flowing into the fresh water supply tank.

NOTE

The water pump switches should be in the OFF position when the recreation vehicle is left unattended for any amount of time.

Maintenance

Periodically check the in-line water pump strainer for accumulated debris. To clean, shut off the water pump, unscrew the clear cap, remove the re-useable metal strainer, clear any debris, then reinstall.

Normal pump maintenance consists of checking and cleaning of the strainer, normal sanitizing and winterizing and occasionally checking all plumbing hardware and fittings for tightness. Lack of sanitizing can lead to premature pump failure and poor performance over time. Scale build-up on the diaphragm and valves, can cause low flow and leak back (occasional pump cycling with no faucets open or tank filling up when hooked up to city water).

For additional information on the care and operation of the pump, read the safety and operating information in the pump manufacturer's owner's manual.

Water Pump Switch

Most water pump switches illuminate when the water pump is activated. Typical switch locations are in the back of the unit or on the monitor panel, or the switch may be part of a touchscreen system (if equipped). When the water pump switch is ON the pump runs until 45 lbs. of pressure has been achieved. The red light will stay on.

WATER PURIFICATION SYSTEM

CAUTION (See page 57)

The canister filter is the primary filter used for the complete water system. If the water supply has not been used for some time, allow the water to flow for several minutes to flush the system.

Filters should be replaced at the beginning of each camping season or if they have come into contact with contaminated water. When not in use, the water filter cartridge should be stored out of freezing temperatures. RV antifreeze will damage the water filter cartridge. Filter locations will vary by model. They are typically located in a compartment behind the utility center (if equipped).

To Replace Canister Filter Cartridge

1. Turn off water supply using two valves located on the water lines on each side of the canister. Water pump should be OFF.
2. Place drip pan below filter housing to catch any spillage.

DRAINING THE FRESH WATER SYSTEM

WARNING (See page 59)

Water tanks may be drained through a valve located near the tank. A recreational vehicle with a demand pressure pump system will have low-point drains attached to the water lines. These low-point drains will release water in the supply lines by opening the valves and all faucets. To drain the permanent fresh water supply lines:

1. Turn the water heater power OFF.
2. Drain the hot water tank (if equipped). It has its own pressure relief valve.

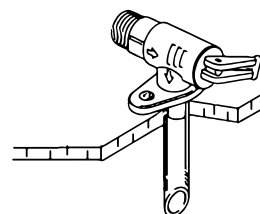

Pressure Relief / Drain Valve

NOTE

See the hot water tank manual for important safety and operating detail.

3. If the water heater has bypass valves, set them to the bypass configuration (See the *Water Heater Bypass Section*)
4. Open all faucets, including the outside shower faucet (if equipped).
5. Open the "fresh tank drain" valve. Methods to drain the fresh water tank may vary by model. Fresh water tanks can be drained by one of the following methods:
 - A white plastic drain attached to the exterior wall
 - A valve located inside the RV adjacent to the water tank (turn 45° to open or close)
 - Pull the white "T" handle on the fresh water holding tank to drain the water
6. Open the low-point drains. Low-point drains are installed at the lowest point of the water lines. A label is placed on the outside of the RV to indicate where the drains are located. The type of drain may vary by model. You will have either an interior or exterior drain.

PLUMBING SYSTEM

- **Interior drains:** the drains will need to be operated from inside the RV. Once the label is found on the exterior sidewall, the drains will be found at a corresponding location in the interior.
- **Exterior drains:** Open the “low point drains” by removing the black screw-on caps on the water lines (coming out from the underbelly). The drains will typically need to be opened from outside the RV.

7. Drain the sink by removing the drain cap.
8. Turn ON the water pump and allow it to run as needed.
9. Operate the toilet flush lever until water stops flowing.

Some water may remain in the lines. If the recreation vehicle will be exposed to cold temperatures, it must be winterized to protect the plumbing system and components. Damage to the water lines and components due to freezing is not covered by warranty. Refer to the *Sanitizing/Winterizing the Plumbing System* for details.

NOTE

To empty the fresh water tank, locate the drain valve under the vehicle chassis close to the tank location. This will empty the tank only.



Low Point Drain Example



Fresh Water Drain Valve

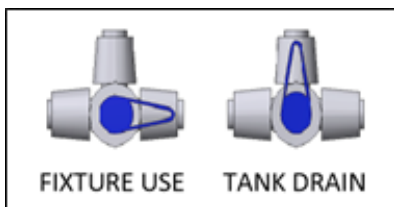

Fresh Water Tank 3 Way Valve Example (If Equipped)



Water Heater Bypass Access

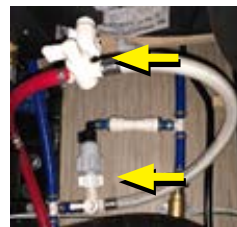

Bypass Access (Normal)

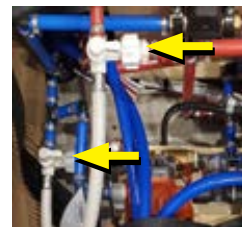

Aqua-Hot Bypass Valves

Normal Mode operation allows water to flow into the water heater. Both hot and cold bypass valve handles should be pointed toward the water heater connections.

Bypass Mode operation diverts the flow of water around the water heater, keeping water out of the water heater. Hot water bypass valve handle should point inline with the (red) hot water outlet line. Cold water bypass valve handle should point inline with the (blue) cold water inlet line.

UTILITY CENTER

⚠ CAUTION ⚠ (See page 57)

Your motor home is equipped with a utility center to assist you in using the fresh water system more effectively. The location of the utility center and type vary by model and/or floor plan.

Fresh Water Holding Tank

Direct access to fill the fresh water tank is typically located in the sofa base, if equipped. The exact location of the fill may vary depending on the model. Remove the cap for direct filling of the water tank. The fresh water tank can also be filled using the city tank fill setting on the utility center.



Water Tank Direct Fill

PLUMBING SYSTEM

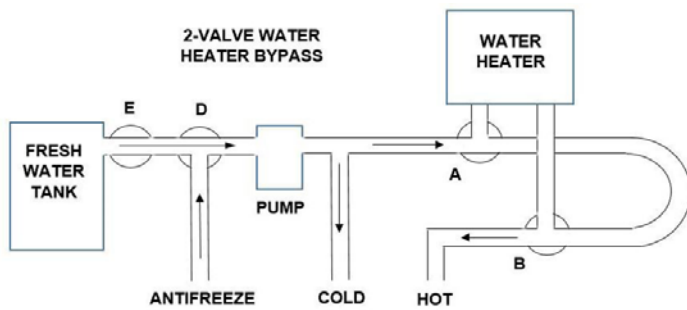

NORMAL - VALVE HANDLES A & B POINT TOWARD THE WATER HEATER.

BYPASS - VALVE HANDLE "A" POINTS IN LINE WITH THE COLD WATER SUPPLY LINE

VALVE HANDLE "B" POINTS IN LINE WITH THE HOT WATER OUTPUT LINE

WATER VALVE (IF EQUIPPED)

Water valve settings indicated on the utility center label:

City Fixtures - Allows you to access water from all faucets using a pressurized water source (referred to from here on as "city water").

- Install the city water connection inlet cap when the city water connection is not being used. The city water connection should be unplugged (i.e., the non-toxic drinking water hose disconnected) when the motor home is unattended for any amount of time.

City Fill Tank - Allows you to fill your fresh water tank using city water.

Country Fill - Allows you to siphon fill your fresh water tank (using the 12-volt water pump) when you do not have access to city water.

Normal - If the RV is not connected to city water, allows you to pump water from the fresh water tank to all faucets using the 12-volt water pump.

Sanitize/Winterize Lines - Allows you to sanitize or winterize the water lines.

Sanitize Tank - Allows you to sanitize the fresh water tank.

NOTE

A short hose is supplied for use in sanitizing or winterizing the water lines in your RV. It can also be used to siphon fill the fresh water tank when no city water is available. One end of this hose has a fitting that will screw onto the city water connection inlet allowing the other end to be put into a container of fresh water, sanitizer or RV antifreeze (refer to Sanitizing/Winterizing the Plumbing System).

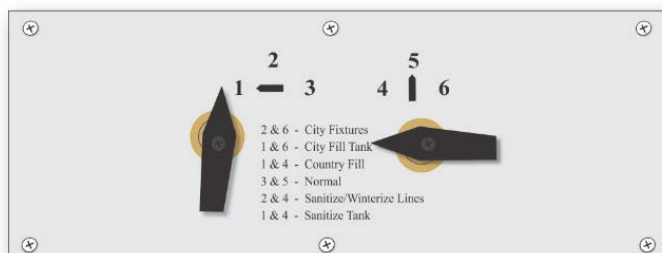

Water Control Valve Operation

City Fixtures: Use this setting if the motor home can be hooked up to an external pressurized water source (referred to as "city water"). If needed, sanitize the water system prior to travel.

- Move the water heater bypass valves (if equipped) to the NORMAL position (supply line valves ON).
- Remove the city water connection inlet cap and attach a non-toxic drinking water hose to the city water connection inlet and the other end to a pressurized water source (such as a faucet or spigot).
- Place the utility center valves in the "CITY FIXTURES" position.
- Turn ON the water at the external water source.
- Enter the motor home and open the cold water supply faucets to bleed air from the water lines. When the water lines are nearly full, you may experience some "air pockets". Allow these to escape before closing the cold water supply faucets.
- Turn the water heater power switch ON. The water will be heated on demand.



City Water Fill w/Connection Label

NOTE

The fresh water connection should be disconnected (i.e., the non-toxic drinking water hose disconnected) when the recreation vehicle is left unattended for any amount of time. If something would happen to the water system, this may help limit water damage to a smaller area.

- The City Water Fill inlet when connected to a pressurized fresh water source sends water through the water lines and fixtures without the use of the pump.

To Disconnect:

- Shut OFF the water at the external water source and disconnect the hose.
- Disconnect the non-toxic drinking water hose from the city water connection inlet and reinstall the city water connection inlet cap.

City Fill Tank: Use this setting to fill the water tank from a pressurized water source. If needed, sanitize the water system prior to travel.

- Set the bypass valves to the NORMAL position (supply line valves ON)
- Remove the city water connection inlet cap. Attach a non-toxic water hose to the city water connection and the other end to a pressurized water source.
- Place the utility center valves in the "CITY FILL TANK" position.
- Turn ON the water at the external source. Water will flow into the fresh water tank.

PLUMBING SYSTEM

During the filling process, periodically check the fresh water tank level using the monitor panel located in the command center. DO NOT OVERFILL THE WATER TANK. When the fresh water tank is full, it is normal to see water running from the fresh water overflow tubes onto the ground.

To Disconnect:

1. Shut OFF the water at the external water source.
2. Disconnect the non-toxic drinking water hose and reinstall the city water inlet cap.

Country Fill: This setting is used to siphon fill the water tank from a water container when dry camping and a pressurized water source is unavailable. If needed, sanitize the water system prior to travel.

1. Set the bypass valves to the NORMAL position (supply line valves ON).
2. Remove the city water connection inlet cap and attach one end of the short hose supplied with the motor home to the city water connection inlet, and the other end into a container of fresh water.
3. Place the utility center valves in the "COUNTRY FILL" position.
4. Turn water pump ON. Water should begin to be drawn out of the container and into the fresh water tank. To aid siphoning place the container on a flat surface approximately 2 feet off the ground. All low point drains must be off in order to create a siphon.

During the filling process, periodically check the fresh water tank level using the monitor panel located in the command center. When the fresh water tank is full, it is normal to see water running from the fresh water overflow tubes onto the ground.

NOTE

The fresh water tank can also be directly filled using the tank fill (located inside of the motor home). See Fresh Water Holding Tank in this section.

To Disconnect:

1. Shut OFF the water pump.
2. Disconnect the short water hose and reinstall the city water connection inlet cap.

Normal Setting: Allows you to use the water system when dry camping. The water pump circulates water from the fresh water tank to all the fixtures. If needed, sanitize the water system prior to travel.

1. Set the bypass valves to the NORMAL position (supply line valves ON).
2. Place the utility center valves in the "NORMAL" position.
3. Turn the water pump ON (make sure you have sufficient 12-volt power).
4. Water will be pumped from the fresh water tank to all faucets.
5. Enter the motor home and open the cold water supply faucets to bleed air from the water lines. When the water lines are nearly full, you may experience some "air pockets". Allow these to escape before closing the cold water supply faucets.

6. Turn the appropriate (12-volt GAS or 120-volt ELECTRIC) storage water heater power switch ON. Turn the water heater power switch. Water will be heated on demand.

Sanitize / Winterize Lines:

This setting is used for drawing RV antifreeze into the water lines of the motor home. When the fresh water tank drain and the low point drains are closed, a siphon is created in the water lines allowing antifreeze to be pulled into the water lines. This setting will not allow antifreeze into the fresh water tank.

Sanitize Tank: This setting is used to sanitize the fresh water tank. When the fresh water tank drain and the low point drains are closed, a siphon is created in the water lines allowing sanitizer to be pulled into the fresh water tank from an external container.

SANITIZING THE PLUMBING SYSTEM

Before sanitizing the plumbing system:

- The Water Heater must be bypassed.
- The Water Purifier must have the filter removed.

Failure to do so could result to damage to the water heater and/or water filter.

When To Sanitize:

- When your recreation vehicle is new.
- At the beginning and end of each season.
- When the water system becomes contaminated or every three months of use.

How to Sanitize

1. Use the main switch or pump switch to turn off the power to the water-pump assembly.
2. Set the water heater bypass valves to the BYPASS position
3. When possible, park the RV on level ground and drain the fresh water system and fresh water tank (see Draining the Fresh Water System).
4. Close the low point drain valves and the fresh water tank drain valve.
5. If the RV has a cartridge type water purifier, the filter must be removed.

Preparing To Sanitize

Prepare a chlorine solution using 1/4 cup of household bleach (sodium hypochlorite solution) to one gallon (3.785 liters) of water in a container. Prepare one gallon of solution for every 15 gallons of tank capacity. This will result in a residual chlorine concentration of 50 ppm in the water system and should remain in system for at least 4 hours.

NOTE

Fresh water tank sizes vary by model. Contact your dealer or customer service for your specific tank size.

1. Place the utility center valves in the SANITIZE TANK position.
2. Attach the short hose supplied with your motor home to the fresh water connection inlet on the exterior of your motor home. Place the other end of the hose in a container holding the sanitized solution. To assist the siphoning process set

PLUMBING SYSTEM

the container on a flat surface approximately (2) feet above ground level.

3. Remove the hose (or funnel) and container used to pour the chlorine solution
4. Attach a hose (can be your drinking water hose) to the fresh water connection inlet and attach the other end of the hose to a potable pressurized water source.
5. Turn on the pressurized water source and finish filling the fresh water tank.
6. After the recommended amount of sanitizing solution is in the tank, the water tank is full, and water filter has been removed from the canister, turn the water pump ON which sends sanitizer into the water lines.
7. Open all hot water faucets one by one until water begins to flow continuously and a chlorine smell is noticeable. Include the shower faucet.
8. Close the hot water faucets and repeat opening all cold water faucets one by one until you smell chlorine. Include shower faucet and toilet.
9. Turn OFF the water pump.
10. Let the solution remain in the tank and lines for at least four hours when disinfecting with 50-PPM residual chlorine, and for at least one hour if using a 100-PPM chlorine concentration.

NOTE

To thoroughly sanitize the fresh water tank, the unit should be driven around for a period of time allowing the solution to splash the sides and top of the tank.

11. After the required period, drain the chlorine solution from the fresh water system and the fresh water tank. See Draining the Fresh Water System.

Rinse The System With Fresh Water:

1. Using a hose or funnel in the tank fill, fill the fresh water tank full of clean (potable) water.
2. Power to water heater should be OFF
3. When the fresh water tank is full, turn the pump ON to send water through the lines. Water heater bypass valves should still be set to BYPASS.
4. Run water through all faucets (hot and cold, including the shower) until chlorine smell is gone. Turn faucets off, turn pump OFF.
5. Drain the fresh water system again (see Draining the Fresh Water System).
6. Set water heater bypass to NORMAL: Allows water into the water heater.
7. Refill the fresh water tank with fresh water again, turn the water heater power ON.

If a chlorine taste lingers in the water, flush the water system with a solution consisting of one-quart vinegar to five gallons of clean water. Re-flush as necessary. The vinegar solution may damage the water heater or the water filter, so both must be bypassed again before performing this operation.

Follow the steps outlined in Draining the Fresh Water System with one exception: do not drain the water heater.

- Water heater bypass valves set to BYPASS.
- Remove the cartridge water filter.

After Draining The System:

1. Water heater power should be OFF. Water heater bypass valves should be set to BYPASS.
2. Put the vinegar solution into the fresh water tank. Pour the vinegar solution into the tank fill using a hose (or funnel).
3. Continue filling the fresh water tank with of clean (potable) water.
4. Run water through all faucets (hot and cold, including the shower) until chlorine smell is gone. Turn the pump ON to send water through the lines.
5. Close all faucets. Turn pump OFF.
6. Drain the system again, but do not drain the water heater.
7. Close low point drains and fresh water tank drain.
8. Refill the fresh water tank with clean potable water.
9. Open faucets and check that the chlorine taste is gone.
10. Drain the system one more time (See Draining the Fresh Water System).
11. Remove water filter canister, insert the filter, and reattach canister to the mount. Water heater bypass valves set to NORMAL.
12. Refill the fresh water system with clean water. When the water heater is full of water, turn the water heater power ON.
13. To verify water heater is full of water, turn on hot water faucets, turn pump ON. When you get a steady stream of water through the hot water faucets, it should be full. Turn off the pump and faucets.

WINTERIZING THE PLUMBING SYSTEM

⚠ CAUTION ⚠ (See page 57)

Preparing your recreation vehicle for colder weather or storage is very important for most states and Canada. Failure to prepare your RV may cause water supply lines and the water heater to freeze. The RV should be winterized at the end of the camping season or when it will be exposed to temperatures that will fall at or below 32°F (0°C). Repairs due to freezing are not covered by warranty. The winterization process may vary slightly due to different plumbing configurations between models.

PLUMBING SYSTEM

Appliances must be winterized. Refer to the manufacturer's manual for possible additional information or contact Customer Service for assistance.

NOTE

The water heater must be drained to prevent damage from freezing. The water heater should be drained and bypassed during the winterization process particularly if introducing RV antifreeze into the plumbing system. Do not drain the water heater while it is hot or under pressure! Antifreeze should be kept out of the water heater.

If you chose to perform the winterization process yourself, read and understand the following information before starting. Contact customer service or your dealer for questions about this process. It may be easier to winterize the RV with another person to assist you.

The preferred method to winterize your recreation vehicle is by using RV antifreeze in the plumbing system.

Winterizing with Antifreeze

⚠ WARNING ⚠ (See page 59)

Requires non-toxic RV antifreeze in the water lines and does not require any special tools. Use ONLY RV ANTIFREEZE in your fresh water system for freeze protection. No other product or commodity should be used.

NOTE

Antifreeze should never enter the water heater, RV water filter, refrigerator, refrigerator water filter, or fresh water tank.

1. Turn water heater power OFF. Turn water heater gas valve (if equipped) OFF (outside of the RV).
2. When possible, park the RV on level ground and drain the fresh water plumbing system. See Draining the Fresh Water System
3. Water heater should be empty after performing Step 2. Water heater bypass valves set to BYPASS. Refer to Water Heater Bypass Section. Water is prevented from entering the water heater
4. Cartridge water purifier filter should be removed.
5. Make sure the "fresh water tank drain" and "low point drains" are closed.
6. Close the fresh water tank shutoff valve.
7. Move the valves to the "Sanitize/Winterize Lines" position. The low point drains must be closed for the antifreeze to siphon through the lines.
8. Attach the short hose supplied with the motor home to the fresh water connection inlet and insert the other end of the hose into a gallon container of RV antifreeze. To assist the siphoning process, put the container on a surface approximately two feet above ground level.

9. Turn the water pump ON. If the water pump fails to self-prime, temporarily open the low point drains. Close the low point drains as soon as the water pump primes (RV antifreeze will begin draining out) and before continuing to the next step.
10. Open the hot water line on all the faucets (kitchen, lavatory, shower and outside shower) until RV antifreeze begins to flow continuously.
11. Appliances should also be winterized.
12. Close the faucet hot water lines and repeat with the cold water lines on all the faucets.
13. Flush the toilet until you see antifreeze in the bowl.

When You Are Done Adding RV Antifreeze

1. Turn the water pump OFF. Turn siphon valve OFF. Remove the clear hose from the container of RV antifreeze. Leave the water tank shutoff valve closed to keep antifreeze out of the fresh water tank. See Water Heater Bypass Diagram.
2. Pour 1 cup of RV antifreeze into the sink drain P-trap.
3. To prevent staining, wipe RV antifreeze out of the sinks, shower (or tub) and toilet using a soft, dry cloth.

NOTE

In the spring when flushing antifreeze out of the water lines, make sure to turn the water tank shutoff valve back ON. After flushing out water lines the water filter should be re-installed.

Air Pressure Method

⚠ WARNING ⚠ (See page 59)

This method uses compressed air to blow out any remaining water in the system after initially draining water using drain valves. Tools required would be an air compressor and a blowout plug.

1. Turn off the water heater gas valve typically located outside the RV. Water heater power should be OFF.
2. When possible, park the RV on level ground and drain the fresh water plumbing system. See Draining the Fresh Water System.
3. Water heater bypass should be set to NORMAL. This allows air to flow through the water heater.

NOTE

Filters should be replaced at the beginning of the camping season or if they have come into contact with contaminated water or antifreeze.

4. RV water filter cartridge should be removed for winterizing. Refer to Water Purification System section.
5. Open the fresh water tank drain valve to avoid pressure build up in the fresh water tank.
6. Run the pump until it is dry (approximately 15 to 20 seconds). Operating the pump longer than that with no water can damage the pump.
7. Open the fresh water tank drain valve to avoid pressure build up in the fresh water tank.

8. Open all faucets in the RV Including the shower.
9. Attach a blowout plug to the city water inlet on the outside of the RV. Refer to Fresh Water Connections.
10. Attach the air hose to the blowout plug. Set compressor to 30 PSI.
11. Blow air into the water lines through the blowout plug and the City Water Inlet to evacuate all water from the lines.
12. Continue blowing out the water lines for approximately 5 to 10 minutes.
13. Pour one cup of RV antifreeze in all the drain P-traps (sinks and shower).
14. After RV water lines have been blown out, remove the air hose and the blowout plug from the City Water Inlet.

Winterize the Black Tank Flush (if equipped)

- Connect the blowout plug to the black tank flush inlet on the outside of the RV.
- Connect the air hose to the blowout plug. Set the compressor to 30 PSI maximum.
- Make sure the black tank has been emptied. Open the black tank drain valve.
- Blow air into the flush inlet for 30 to 60 seconds.
- Disconnect the compressor and blowout plug.
- Close the black tank drain.

UTILITY CENTER (P2 OR P4 NAUTILUS)

The Utility Center allows you to perform the following functions:

- Power fill the fresh water tank for remote or dry camping
- Use the pump to supply water to fixtures from the fresh water tank
- Use the pump to siphon fill or sanitize the fresh water tank from a bucket
- Connect to city water at the camp site to supply water to RV fixtures
- Winterize the plumbing lines and fixtures
- Rinse off items outside the unit with a hot/cold faucet



P2 Example



P4 Example

City Water Connection Inlet

CAUTION (See page 59)

Use a non-toxic drinking water hose dedicated only to supplying fresh water. To prevent contamination, keep the non-toxic drinking water hose from coming into contact with the ground. Install the city water connection inlet cap when the fresh water connection is not being used. The fresh water connection should be disconnected (i.e., the non-toxic drinking hose disconnected) when the recreation vehicle is unattended for any amount of time.

NOTE

If the utility center is used for a continual water source, the back door of the motor home will need to remain open.

City Water (Pressurized Fresh Water Source)

The City Water connection allows you to power fill your fresh water tank. It can also be used as a fresh water supply using your non-toxic drinking hose.

1. Connect the fresh water hose to the CITY WATER inlet.
2. Set the color-coded valves to the CITY WATER setting (refer to the Utility Center label for valve configuration).
3. Connect other end of the hose to the pressurized fresh water source.
4. Turn ON the pressurized water source.
5. Water should now be available to all fixtures in the RV.

To disconnect from city water, turn off water at the pressurized source first. Disconnect the hose from the water source, (to release pressure off the system) then disconnect the hose at the city water connection on utility center last.

Filling The Fresh Water Tank (Pressurized Fresh Water Source)

1. Connect the fresh water hose to the CITY WATER inlet on the utility center.
2. Set the color-coded valves to the POWER FILL TANK position (refer to the Utility Center label for valve configuration).
3. Connect the other end of the hose to a pressurized fresh water source (faucet or spigot).
4. Turn the pressurized water source ON, the tank should begin filling.
5. When water has reached the desired level, turn the pressurized water source OFF. DO NOT OVERFILL (tank level can be viewed on the monitor panel on the touch screen).
6. Disconnect water source from the spigot/faucet first, then disconnect from the city water fill inlet on the utility center.

Dry Camping (Pump Supplies Water From The Fresh Water Tank)

1. Make sure the fresh water tank has an adequate supply of water.
2. Set the color-coded valves to the DRY CAMPING setting position (refer to the Utility Center label for valve configuration).
3. Turn the pump switch ON. The LED indicator light below the pump switch will be lit if the pump has power.
4. Water should be available to all fixtures. Pump runs when a fixture is opened.
5. Turn pump OFF when water is not being used.

NOTE

To fill the fresh water tank without a pressurized water source, refer to SANITIZE (Siphon Fill) section, and use a container holding fresh potable water and your fresh water hose. Water will be drawn into the tank by the pump. There is no gravity fill inlet on the recreation vehicle.

Handheld Shower

A handheld shower assembly with both hot and cold water is included for use outside of your recreational vehicle.

- Be sure the water heater is ON and had sufficient time to heat the water.
- If dry camping, be sure the 12-volt water pump is ON.
- Remove the handheld shower from its holder.
- Turn ON the hot and cold faucet knobs, and adjust the water temperature as desired.
- To activate the handheld shower turn ON the sprayer head attachment (some models).

To turn off the water, always close the hot/cold control (faucet) knobs. The lever on the showerhead will not completely stop the flow of water; this is intentional to allow for draining. After the water has been allowed to drain from the showerhead, return it to the outside shower storage. Any remaining water in the shower hose will drip or run out; this is not a leak but performs as intended. If you are dry camping, turn the water pump OFF.

Turning off the water with the showerhead lever can also create a condition where the hot and cold water will mix through the outside shower faucet, thereby reducing the temperature of the hot water. It can appear as though the hot water heater is not working properly.

NOTE

The showerhead may be removed from the hose so that it will drain faster. If you remove the showerhead, be sure to reassemble it prior to storage. When putting the shower assembly back into the storage compartment, make sure the hose is not pinched or the showerhead is positioned in a way it can be damaged.

SANITIZING THE PLUMBING SYSTEM

- When your RV is new.
- At the beginning and end of each season.
- When the water system becomes contaminated or every three months of use.

Preparing To Sanitize

Prepare a chlorine solution using 1/4 cup of household bleach (sodium hypochlorite solution) to one gallon (3.785 liters) of water in a container. Prepare one gallon of solution for every 15 gallons of tank capacity. This will result in a residual chlorine concentration of 50 ppm in the water system and should remain in system for at least 4 hours.

NOTE

Fresh water tank sizes vary by model. Contact your dealer or customer service for your specific tank size.

How to Sanitize

1. Set the colored valves to SANITIZE setting (refer to the Utility Center label for valve configuration).
2. Level the recreation vehicle and drain the fresh water system (see Draining the Fresh Water System).
3. Close the low point drain valves and the fresh water tank drain valve.
4. If the RV has a cartridge type water purifier, the filter must be removed.
5. Attach a short section of garden hose to the SANITIZING/WINTERIZING inlet at the utility center. DO NOT use your fresh water hose for sanitizing.
6. Insert the other end of the short hose into a container holding the chlorine solution.
7. Turn the pump switch ON (red LED will light). The solution will be drawn into the fresh water tank. Turn the pump OFF when solution has been drawn into the tank. To aid in siphoning, set the container on a surface approximately (2) feet off the ground. The drain valves must be turned OFF.
8. Disconnect the short hose from the SANITIZING/WINTERIZING inlet. Leave the colored valves in the SANITIZE position.

Power Fill Water Tank

9. Attach your fresh water hose to the SANITIZING/WINTERIZING inlet at the utility center. Connect the other end of the hose to a pressurized water source. Turn the water on and finish filling the water tank with fresh water. DO NOT OVERFILL THE TANK!

Siphon Fill Water Tank

If there is no pressurized water source available, fresh water can be siphoned into the water tank from an external container (bucket). Fresh water hose should be connected to the SANITIZING/WINTERIZING inlet, other end of the hose placed in the bucket of water. Colored valves should still be in SANITIZE position. Turn the pump ON and water will be siphoned into the tank. DO NOT OVERFILL THE TANK

10. When the tank is full, turn off the water source. Disconnect the hose from the faucet/spigot first. Then disconnect the hose from the utility center panel.

At this point the following conditions should be met:

- Water filter has been bypassed or removed (depends on model).
 - Sanitizer has been put into the tank.
 - Water tank is full having been topped off with fresh water.
11. Set the valves to the DRY CAMPING setting.
 12. Turn the water pump ON and sanitized water will flow into the water lines from the water tank when a fixture is opened.
 13. Open hot water faucets one by one until water begins to flow continuously and a chlorine smell is noticeable. Close hot water faucets. Repeat this process with the cold water faucets. Include outside shower faucets.

14. Turn OFF the water pump.
15. Let the solution remain in the tank and lines for at least twelve hours when disinfecting.

NOTE

To thoroughly sanitize the fresh water tank, the unit should be driven around for a period of time allowing the solution to splash the sides and top of the tank.

16. After the required period, drain the chlorine solution from the fresh water system.

Rinse The System With Fresh Water

17. Fill the fresh water tank full of clean (potable) water. Use water either from a pressurized source, or from a container (as detailed below).
18. When the fresh water tank is full, set the valves to the DRY CAMPING setting. Turn the pump ON to send water through the lines.
19. Run water through all faucets (hot and cold, including outside shower) until chlorine smell is gone. Turn all faucets and outside shower off, turn pump OFF.
20. Drain the fresh water system again. The bypass hose can be removed from the water filter canister and the filter re-installed.
21. Refill the fresh water tank with fresh water again.

If a chlorine taste lingers in the water, flush the water system with a solution consisting of one-quart vinegar to five gallons of clean water. Re-flush as necessary. Remove the canister water filter as the vinegar solution may damage the water filter.

Follow the steps outlined in Draining the Fresh Water System Remove or bypass the water filter.

After Draining The System:

1. Put the vinegar solution into the fresh water tank.
2. Set the colored valves to the SANITIZE setting.
3. Attach a short hose to the CITY WATER inlet. Put the other end of the hose in a container with the vinegar solution. Do NOT use your fresh water hose. Turn the water pump ON. The solution will be drawn into the fresh water tank When the container is empty, turn pump OFF, and disconnect hose from utility panel.
4. To aid in siphoning, place the container approximately (2) feet off the ground. The drain valves must be closed.
5. Fill the fresh water tank full of clean (potable) water. Use water either from a pressurized source, or from a container.
6. Set the valves to the DRY CAMPING setting. Run water through all faucets (hot and cold, including outside shower and outside kitchen if applicable) until chlorine smell is gone.
7. Close all faucets including outside shower. Turn pump OFF.
8. Drain the system again.
9. Close low point drains and fresh water tank drain.

10. Refill the fresh water tank with clean potable water. Use the CITY WATER CONNECTION inlet.
11. Open faucets and check that the chlorine smell is gone.
12. Drain the system one more time.
13. Replace the water filter.
14. Refill the water tank. All drain valves should be turned OFF.
15. After filling the water tank, set the valves to either DRY CAMPING (which uses the water pump) or CITY WATER (which uses pressurized water) to send water through the plumbing system.

WINTERIZING THE PLUMBING SYSTEM

Preparing your recreation vehicle for colder weather or storage is very important for most states and Canada. Failure to prepare your RV may cause water supply lines and the water heater to freeze. The RV should be winterized at the end of the camping season or when it will be exposed to temperatures that will fall at or below 32°F (0°C). Repairs due to freezing are not covered by warranty.

If you choose to perform the winterization process yourself, read and understand the following information before starting. It may be easier to winterize the RV with the aid of a second person. The winterization process may vary slightly due to different plumbing configurations between models.

NOTE

Appliances (refrigerator) must be winterized. Refer to the appliance owner's manual for additional information or contact your Dealer or Customer Service for assistance. The preferred method to winterize your recreation vehicle is by using RV antifreeze in the plumbing system.

Winterize with Antifreeze Method

⚠ WARNING ⚠ (See page 59)

Requires non-toxic RV antifreeze in the water lines and does not require any special tools. Use ONLY RV ANTIFREEZE in your fresh water system for freeze protection.

No other product or commodity should be used. Antifreeze should never enter the water heater, RV water filter, refrigerator, refrigerator water filter, or fresh water tank.

1. Drain the fresh water plumbing system. Refer to Draining the Fresh Water System. Parking the RV on level ground will aid in draining the plumbing system.
2. Remove water filter:

Cartridge Style: Replace filter with the bypass tube supplied with the RV.

NOTE

Filters should be replaced at the beginning of the camping season or if they have come into contact with contaminated water or antifreeze.

3. Make sure the "fresh water tank drain" and "low point drains" are closed. This includes the refrigerator low point drains (if equipped).

PLUMBING SYSTEM

- Set the colored valves to WINTERIZE setting (refer to the Utility Center label for valve configuration).
- Attach a short hose to the CITY WATER inlet. Place the other end of the hose in a container of antifreeze. Do NOT use your fresh water hose for winterizing.
- Turn the water pump ON with the pump switch on the utility center panel (LED indicator light will be lit if the pump has power). Antifreeze will be drawn into the water lines when a fixture in the RV is opened. To aid in siphoning, place the container approximately (2) feet off the ground. The drain valves must be closed.
- Open the hot water faucets one at a time (kitchen/bath sinks, shower, outside shower and outside kitchen (if equipped) until RV antifreeze begins to flow continuously. Then close each faucet.
- Repeat with all the cold water line faucets (kitchen/bath sinks, shower, outside shower).

When You Are Finished Adding RV Antifreeze:

- Turn the water pump OFF with the switch on the utility center panel.
- Remove hose and container from the WINTERIZE inlet. Put the cap back on the inlet. Leave the colored valves in WINTERIZE position.
- Wipe any RV antifreeze out of the sinks, with a soft, dry cloth.

Contact your dealer if you require further assistance.

Winterize with Air Pressure

 **WARNING** (See page 59)

This method uses compressed air to blow out any remaining water in the system after initially draining water lines using drain valves. Tools required would be an air compressor and a blowout plug.

- When possible, park the RV on level ground and drain the fresh water tank, the tank (storage) water heater and the hot and cold water lines. Open all low point drains and the fresh water tank drain. Faucets inside the RV should be opened to relieve pressure to allow water lines to drain. Refer to Draining the Fresh Water System section.
- Water filter should be removed for winterizing. See Water Purification System section.

Cartridge Water Filter: Remove the cartridge filter and replace it with a bypass hose (supplied with your RV).

- Turn the (color) valve handles to the correct position.
 - P2 Panel = TANK FILL position
 - P4 Panel = POWER FILL position
- Low point drains should be open to remove water from the lines.
- Open all faucets in the RV. If there is an outside shower, attach the shower hose to the shower, and open shower faucets.
- Run the water pump until pump is dry (approximately 15 to 20 seconds). Do not operate pump longer than that without water, it can damage the pump.

- After water is drained from the lines, turn the following selector hand so they are at 45°.
 - P2 Panel = Blue and Green
 - P4 Panel = Red, White, Blue and Green
- Attach a blowout plug to the CITY WATER inlet on the utility center panel.
- Attach the air hose to the blowout plug. Set the compressor to 30 PSI.
- Blow air into the utility center (30 PSI Max). Water lines should be clear in 5 to 10 minutes.
- Turn off air supply, remove air hose and blowout plug.
- Close low point drains, replace the water heater drain plug.
- Set the colored valves to the WINTERIZE positions.

Refer to the Utility Center manufacturers User Guide for additional operating information.

TRUMA® COMBI DIESEL 2 in 1 SYSTEM (IF EQUIPPED)

 **WARNING**  **CAUTION** (See page 59) & (See page 58)

Your recreation vehicle may be equipped a Truma® Combi furnace with supplementary indirect water heating. Refer to the manufacturer's owner manual, for important operating and safety information.

AQUA-HOT® WATER HEATER (IF EQUIPPED)

Your recreation vehicle may be equipped an Aqua-Hot furnace with supplementary indirect water heating. Refer to the manufacturer's owner manual, for important operating and safety information.

TIMBERLINE FURNACE/WATER HEATER (IF EQUIPPED)

Your recreational vehicle may be equipped with a Timberline heat & hot water system.

Refer to the manufacturer's manual for detailed operating and safety information.

Timberline heat and hot water is generated by the Autoterm Binar Compact heating unit made for the most adverse conditions. A heated glycol solution is circulated through the interior of the living space through air handlers that provide radiant heat. The glycol is also circulated through an instantaneous water heat exchanger which produces hot water. By using the diesel or gasoline burner along with the 110V electric element, it provides efficient comfort whether dry camping or plugged into shore power.

Maintenance

Hydronic System

- The glycol system does not require annual maintenance.
- It is recommended to test the alkalinity in the system coolant annually.

Domestic Water

- The domestic water loop does not require annual maintenance.
- Calcium build-up over time will act as an insulator. The exchanger unit can be back-flushed with a lime removal cleanser.

Fan Unit(s)

- The fan unit does not require annual maintenance.

Furnace

- The Timberline system is equipped with the efficient Autoterm Binar Compact Diesel or Gasoline burner. This burner is designed for optimal use in all climates including high altitude up to 10000 feet. There is limited required maintenance for the Autoterm burner.
- It is recommended to exercise the burner every month letting the burner run for 15-20 minutes. If the burner is utilized monthly there is no annual or hour based maintenance required.

Exhaust System

- The exhaust system should be inspected annually for damage.

Winterization

System Coolant

- The system coolant does not require winterization.
- The system coolant can be tested for its freeze protection value.

Domestic Water System

- The domestic water circuit needs to be drained or protected using RV winterizing fluid. Propylene-glycol can be pumped through the system using the domestic water pump and opening both hot and cold valves at a plumbing fixture. Using this procedure does not require draining the Demand Hot Water exchanger.

Refer to the *Draining the Fresh Water System and Winterizing the plumbing system section.*

FAUCETS

The bathroom, kitchen and outside shower faucets operate much the same way as the faucets in your home. Make sure there is sufficient water available and the 12-volt water pump is turned ON before operating.

NOTE

There may be air in the water plumbing lines which needs to be bled out before a steady stream of water comes from the faucet.

BATHROOM TUB / SHOWER

⚠ WARNING ⚠ (See page 59)

Keep the water heater and holding tank capacities in mind when using the fresh water system. The used water will drain into the grey water holding tank.

- Be sure the water heater is ON and had sufficient time to heat the water.
- If dry camping, be sure your 12-volt water pump is ON.

Unlike your home, the recreational vehicle does not contain a water pressure balance valve. If someone is using the shower, it is recommended that the fresh water system **NOT BE USED** until they are finished.

The shower faucet may include a vacuum breaker for the shower. There are two purposes for this breaker:

- To prevent siphoning water through the hose from another fixture.
- To prevent water from being retained in the hose.

The showerhead DOES NOT have a complete shut-off valve (the complete shut-off is at the faucet). The showerhead may drip slightly in the OFF position after use; this is normal and does not indicate a leak or defect.

Maintenance

Refer the manufacturer's user guide or label instructions for detailed cleaning information. The tub/shower walls are made of ABS plastic material. Use a mild detergent soap and warm water to clean. Do not use gritty or abrasive particle soaps or scouring compound to clean ABS plastic. Avoid using "Citrus" or biodegradable cleaners which contain "D-Limonene." They will damage plastic materials.

SHOWER MISER

⚠ CAUTION ⚠ (See page 58)

The Shower Miser is a device attached to your inside shower that helps to conserve water especially when you are dry camping and are restricted to the amount of water available in your fresh water tank and don't have ready access to a water supply.

The device is installed on the incoming water line for the shower and will circulate water from your water heater, back into your fresh water tank until the water in the shower comes up to temperature. This prevents needlessly dumping your limited supply of water waiting for the shower to heat up.

Operation

The device consists of a small valve and a blue plastic "dot" below the shower handle.

When the small valve (on the Shower Miser) is in the closed (OFF) position, wasted cold water is directed to the fresh water tank. No water will flow through the shower head. The blue "dot" will be dark blue when cold water is running through the shower plumbing. When the water is up to temperature, the blue "dot" will change color from a dark blue to white which indicates the water flowing into the shower is now hot. Turn the small valve the opposite direction (to ON) and turn on the shower valve so water flows out of the showerhead. The color change is obvious so there is no question when the water is at a comfortable temperature.

As you shower, the small Shower Miser valve can be turned OFF while you use the soap, so water will divert into the fresh water tank instead of down the drain, and it keeps the water up to temperature, so when you turn the Shower Miser valve back ON, you immediately have hot water to rinse with.

The Shower Miser system may vary depending on your model.

PLUMBING SYSTEM

Filling The Fresh Water Tank

Shower Miser will also fill the fresh water tank from inside the RV when hooked up to a pressurized water source.

- A pressurized water source must be connected to the RV and turned ON.
- Check the tank monitor to see how much fresh water is in the tank.
- Turn the lever on the Shower Miser to bypass the showerhead (OFF).
- Turn the cold water shower valve fully ON.
- Watch the tank monitor as the fresh water tank fills.
- When tank is full, turn the cold water shower valve OFF.

BLACK/GREY WATER SYSTEM AND TANKS

Water from the sinks and shower flows into the gray water (or wastewater) holding tank. Water from the toilet will flow into the black water (or sewage) holding tank (see *Black/Grey Water Holding Tanks*).



Waterless Trap

Drain Pipes with P-Trap (if equipped)

The drain pipes may be equipped with a “P-trap” installed to help prevent odors from escaping into the RV. During travel, water from the P-traps may spill and permit odors into the RV. By adding water and using a RV approved deodorizing agent you will dissolve the contents faster and will keep the drain lines and tanks clean and free flowing. These chemicals are available at an RV supply store or your dealer.

Drain Pipes with Dry Sealing Valve (if equipped)

Your RV may be equipped with a dry sealing valve that prevents the escape of odors from your waste system and eliminates the need for P-traps. Should the RV drain piping system become clogged, it is important that the dry valve be removed before passing a mechanical cleanout tool through the piping to open the drain. Passing a cleanout tool through the waterless valve may cause damage to the internal seal that may potentially allow sewer gases to escape into the RV interior. The waterless trap can be unscrewed from the water lines.

A label has been placed near the location of the waste valve that reads as follows:

REMOVE WATERLESS TRAP BEFORE
USING MECHANICAL DRAIN CLEANING DEVICES

Sewer Hose Storage

Depending on your RV model, the sewer drain hose may be stored in an exterior compartment marked “Sewer Hose” or it may be located in the hollow square tube bumper. The bumper has removable plastic end caps, and the hose slides inside the hollow bumper.

Vents

Vent pipes and vents release air from the grey and black water holding tanks. On most models the exterior vent cap is attached to the roof and must be kept clear of obstructions to perform as intended.

On some models, the vent pipe may be part of the drainage system referred to as a “wet vent” where water flows downward as air flows upward in the same pipe.

Some models are equipped with a side vent system. On these models this label will be next to the termination valve. This label should not be removed from your recreation vehicle.

CAUTION

Keep drain valve closed to minimize the presence of sewer gases. Sewer gases may be present when RV is connected to campground sewage hookup. May lead to illness or personal injury.

Black/Grey Water Holding Tanks

WARNING **CAUTION** (See page 58) & (See page 58)

Dump the gray and black water holding tanks before traveling to avoid carrying unnecessary weight. The weight of the holding tank contents is not calculated into the RV cargo carrying capacity. Traveling with full holding tank(s) could cause you to exceed the individual tire ratings and/or the RV GAWR or RV GVWR. Potential damage to suspension components, such as springs, tires and axles, could result.

If you are dry camping and cannot immediately empty your holding tanks, reduce your vehicle speed until you reach a dumping station. When connected to the sewer drain line at a campground, keep the black tank drain valve closed until the holding tank is at least $\frac{3}{4}$ full. This will provide sufficient water to assist in complete draining of the black water holding tank. Repeat as needed.

Before using the recreation vehicle, or after dumping the grey and black water holding tanks, always add the proper amount of deodorant to the black water tank to prevent odors and help break down holding tank contents (unless winterizing). Follow the deodorant bottle or package instructions. Driving to a disposal site will normally loosen any accumulated waste debris or solids from the sides of the holding tanks.

BLACK AND GREY TANK DRAINS

There are labels on the exterior of the recreation vehicle indicating the location of the grey and black tank drains (also called dump valves). Depending on your model, you may have one or two valves. With one valve, the gray and black tank will release contents simultaneously. With the 2-valve set up, it is recommended that you release the black tank first, followed by the grey tank. This will help rinse and debris from the outlet and sewer hose.



Black / Grey Tank Drain Valve

1. To make drainage easier, level the RV.
2. Remove the sewer hose housing dust cap and attach the sewer hose (customer supplied).
3. Place the end of the sewer hose into the approved dump station.
4. Open the black tank dump valve (depending on your model the valve may be located under the RV, or on the utility center). Close the dump valve when the black water holding tank is empty.

5. Open the grey tank dump valve (depending on your model the valve may be located under the RV or on the utility center). Close the dump valve when the grey holding tank is empty.
6. Remove, clean and store the sewer hose.
7. Close the sewer hose housing dust cap.

You can locate dump stations throughout the United States and Canada in Woodall's, Rand McNally Camp Guide, Good Sam Camp Guide, KOA Campgrounds Camp Guide and various other publications. Some fuel stations also have dump stations. Please contact your RV dealer for assistance in the purchase and installation of a sewer hose or sewer hose extension (if needed).

Sewage (Black) Tank Preparation

⚠ WARNING ⚠ (See page 58)

1. Release one to two quarts (1 or 2 liters) of water into the toilet bowl.
2. Follow the directions on your RV-approved toilet chemical bottle (customer supplied) and put the recommended quantity of holding tank chemical into the toilet bowl.
3. Flush the toilet and allow at least two gallons (8 liters) of water to flow into the holding tank.

Waste (Grey) Holding Tank Preparation

No special preparation is required, however, placing a small quantity of chemicals into this tank, such as baking soda or an approved RV chemical, will reduce odors from food particles in the system.

Cleaning and Maintenance

The toilet should be cleaned regularly for maximum sanitation and operational efficiency. Use only RV approved chemicals. Do not use chlorine (undiluted) or caustic chemicals, such as laundry bleach or drain opening types, in the toilet system. These products damage the seals in toilets and dump valves.

TANK HEATERS (IF EQUIPPED)

⚠ CAUTION ⚠ (See page 58)

Your recreational vehicle may be equipped with heaters for the fresh, gray, black water tanks. The larger tank heaters are 12VDC and attach directly to the tanks. The thermostat controlled tank heaters will cycle on at 44°F (7°C) and off at 64°F (18°C). All of the heaters are controlled by a single ON/OFF button that is typically located on the Command Center Panel or Firefly Touchscreen. The button lights up when 'ON' and controls the heater circuit.

The Tank Heater Button Should Be Turned On:

- When liquid is present in the holding tanks and the outside temperature approaches and maintains freezing conditions 35°F (2°C) or colder.

The Tank Heater Button Should Be Turned Off:

- When there is NO liquid present (tanks are empty).
- When dumping the black and gray holding tanks and the drain pipes.
- When fresh water tank and supply lines are empty or being drained for storage.
- When the recreation vehicle is connected to city sewer and the gate valves are open.

NOTE

Free draining is never recommended, especially in cold weather use.

- When ambient temperatures rise and remain above freezing.

No maintenance on the heaters is required, only a periodic inspection for loose wires, damage, etc. For additional detailed information, refer to the tank heater manufacturer's user guide.



PLUMBING SYSTEM CAUTION

WATER PRESSURE REGULATOR (See page 44)

A water pressure regulator is recommended to prevent damage to the plumbing system or components. To prevent damage when using the city water connection, a 45 lb. (315 KPa) rated water pressure regulator is recommended.

FRESH WATER HOLDING TANK (See page 55)

- Do not cap, block or modify the fresh water tank overflow tubes in any way. Enough water pressure can build up during the filling process to damage the plumbing system if the overflow tubes are obstructed.
- Be careful not to overfill the fresh water holding tank. It can pressurize the tank, causing leakage and water damage and void the warranty. DO NOT leave the tank unattended while filling.

TIMBERLINE FURNACE/WATER HEATER (See page 54)

Damage to the furnace caused by freezing!

- Water in pipes, faucets and appliances could freeze. Considerable damage may result.
- Damage from freezing is not covered by the limited warranty.



TRUMA® COMBI DIESEL 2 in 1 SYSTEM (See page 54)

Damage to the Combi furnace caused by freezing!

- The Combi furnace does not have a frost-protection function. If the heating is not used and there is a risk of freezing, all water must be drained from the water container
- Water in pipes, faucets and appliances could freeze. Considerable damage may result.
- Before you fill water into appliances and parts that transport water, you must heat the installation area sufficiently so that water cannot freeze.
- No warranty claims are accepted by the manufacturer of the Combi furnace for frost/freeze damage

WATER PURIFICATION SYSTEM (See page 45)

- Do not allow water in the canister housing to freeze.
- Remove the filter before using anti-freeze to winterize the system or chlorine solution to sanitize the system.
- Flush canister housing thoroughly before it is put back into service after winterizing or sanitizing.
- For best results replace filter every 6-12 months.
- Do not use carbon cartridges where water is microbiologically unsafe or of unknown quality.
- Maximum operating pressure is 125 psi (8.75 bar).
- Maximum water temperature is 125° F (52° C).

SHOWER MISER (See page 58)

When using the Shower Miser with pressurized city water hookups the fresh water tank can overflow on to the ground.

CITY WATER CONNECTION INLET (See page 51)

A check valve is located inside the city water connection inlet on the utility center. NEVER depress the check valve on the "CITY WATER CONNECTION" inlet with pressure in the line. It will cause irreparable damage to the valve function and the inlet will leak water.

BLACK/GREY WATER HOLDING TANKS (See page 56)

Never leave the black tank drain in the open position continuously when connected to the campground sewer system. Leaving the drain open will allow the liquid to drain out increasing the potential for a blockage in the tank. Keeping the drain in the closed position will prevent debris from accumulating in the tank.

- Do not add automotive antifreeze or caustic chemicals, such as laundry detergents, into the holding tanks. Although these products may have a deodorizing effect, they may damage the plastic and rubber parts of the plumbing system or the components

TANK HEATERS (See page 57)

The red light on the switch does not necessarily indicate that ALL heaters are operating; it is only a warning that the heater circuit is ON.



SEWAGE TANK PREPARATION (See page 58)

It is important to add enough water to prevent solid waste buildup. Follow the directions listed below and in the manufacturer's operator manual.

WINTERIZING THE PLUMBING SYSTEM (See page 53)

If the motor home is going to be stored in a non-temperature controlled environment with a risk of temperatures reaching 32°F (0°C) or lower, the demand (power) system with RV antifreeze **must** be used in the motor home plumbing system as directed in this manual. This includes appliances such as the washer, dishwasher and the refrigerator

BLACK/GREY WATER HOLDING TANKS (See page 56)

Never travel with full black or grey water holding tanks. Depending on the location of the tank(s) it can affect your tow vehicle handling characteristics.



FRESH WATER SYSTEM (See page 44)

- DO NOT drink water deemed microbiologically unsafe or of unknown quality.
- Avoid traveling with full fresh, black or grey water holding tanks. The weight of holding tank contents is not calculated into the RV cargo carrying capacity. Traveling with full tanks could cause you to exceed the individual tire ratings and/or the RV GAWR or GVWR. Traveling with full tanks can also affect your vehicle handling characteristics.

WINTERIZING WITH ANTIFREEZE (See page 49)

Automotive antifreeze (ethylene glycol) and windshield washer antifreeze (methanol) are poisonous. Never use these products in your fresh water system. These products are harmful and may be fatal if swallowed.

AIR PRESSURE METHOD (See page 54)

- Never apply air pressure to the water system with any of the valves in the closed position. Air pressure applied to a closed valve, faucet or low point drain could potentially damage the seals and cause water leaks. If you have questions, consult with your RV dealer. Using RV antifreeze is the preferred method of winterization.
- Recommended pressure is 30 PSI, exceeding this pressure may rupture water line couplings and void your warranty.

AIR PRESSURE METHOD - P2 OR P4 NAUTILUS (See page 51)

Before applying air pressure to the utility center, the (2) colored valves MUST be set to 45° or damage may occur to the utility center.

Never apply air pressure to the water system with any of the valves in the closed position. Air pressure applied to a closed valve, faucet or low point drain could potentially damage the seals and cause water leaks. If you have questions, consult your RV dealer. Using RV antifreeze is the preferred method of winterization.

Recommended air pressure is 30 PSI MAX. Exceeding this pressure may rupture water line couplings and void your warranty.

TIMBERLINE FURNACE/WATER HEATER (See page 54)

Scalding injuries caused by hot water!

- Water temperatures over 125 °F (49 °C) can cause severe burns or scalding and in extreme cases even death.
- Before using a hot water faucet or using the shower, mix with cold water and allow the hot water to run until the water temperature no longer increase.

BATHROOM TUB/SHOWER (See page 55)

Water temperatures over 125°F (49°C) can cause severe burns instantly therefore, be careful when using hot water. **Always test the water temperature before showering or washing.**

TRUMA® COMBI DIESEL 2 in 1 SYSTEM (See page 54)

Danger of combustion, personal injury and damage to the RV!

- Keep the area around the appliance free from combustible materials, gasoline and other flammable liquids or vapors.
- Switch OFF the appliance and gas supply:
 - If you smell gas
 - If anything appears out of the ordinary
 - If you move the RV
 - Before entering a gas station
 - Before entering a tunnel

Danger of over-temperature and toxic exhaust gases!

- Use with LP gas (propane) only. Butane or any mixtures containing more than 10% butane must not be used.
- Keep the area in front of the warm air outlets free of combustible or heat-sensitive materials. Do not put any material into the warm air outlets.
- Check that furnace vent (and air intake) terminal(s) are not obstructed in any way during all seasons.
- Danger of hot surfaces. The temperature of the exhaust gases can reach 320 °F (160 °C). Do not touch the area around the wall cowl and do not lean any objects against the wall cowl or the RV.
- Shut OFF the Combi furnace when refueling or pumping gas.

SECTION 8: HEATING & COOLING



AIR CONDITIONER

Cooled air enters the RV through the grill. Make sure you have sufficient power available before operating the air conditioner. Do not operate the air conditioner without the return air filter. Operating the system without the filter allows the lint and dirt that is normally stopped by the filter to accumulate on the cooling coil of the air conditioner. This also will lead to a loss of air volume, possible equipment damage and an expensive cleaning process.

Roof Mount Foam Gasket (If Equipped)

A special foam gasket is placed between the roof material and the sub frame of the air conditioner to guard against water leakage. The air conditioner is subjected to wind pressures along with motor vibration during normal operation. Inspect the mounting bolts for tightness to ensure there is no leakage or looseness at least annually. Re-tighten bolts when they are loose. DO NOT over tighten these bolts as it may damage this gasket. The air conditioner gasket is a wearable part that eventually will need to be replaced. To gain access to the bolts, remove the filtered panel cover on central air systems or the entire air box on non-central air conditioners.

Heat Pump Operation (If Equipped)

CAUTION (See page 62)

Set the thermostat for either electric or gas heat. On the electric setting, the heat pump will become the primary heat source as long as the interior temperature of the RV has not dropped 5° below the thermostat set point. If this occurs, the thermostat will automatically activate your gas furnace.

The furnace will continue as the heat source until the thermostat set point has been satisfied. At that point, the heat pump will again become the primary heat source.

For RV models with a touch screen system, the heating cooling controls are included on the touch screen selectable screens. **For additional information** refer to the manufacturer's owner's manual included in your warranty packet or consult your dealer.

Firefly (If Equipped)

All controls for the heating/cooling climate control system are incorporated into the touch screen system. For specific operating instructions for heating/cooling controls, refer to the touch screen user guide included in your warranty packet or online at <http://www.fireflyint.com>.

HEATING & COOLING

The air conditioner/heat pump heats and cools from a single unit. The heating unit will not replace a furnace for heating your motor home in cold weather. It is designed to warm the coach during cool or mild temperatures. Both the heating and cooling unit are controlled by a single thermostat which is controlled through the Vega Touch screen.

In the cooling mode, the temperature drop from inlet to supply will be 15 to 20 degrees. In the heating mode the temperature rise from inlet to supply will be 25 to 40 degrees unless the outdoor temperature has dropped sufficiently to cause the freeze switch to activate. In that case, the rise will be only 10 to 20 degrees. Any deviations from these norms are cause to examine the system for dirty air filters or outdoor coil. Parking the vehicle in a shaded area, keeping windows and doors shut and avoiding the use of heat producing appliances in the vehicle will help to reduce the heat gain.

Maintenance

The only required maintenance on the heat pump is cleaning and replacing the filters. The filters can be cleaned and reused. It is recommended that filters be cleaned and changed at least every 2 weeks when the heat pump is in operation.

Refer to the manufacturer's manual for important safety and operating information.

TRUMA® COMBI DIESEL 2 in 1 SYSTEM (IF EQUIPPED)

⚠ WARNING ⚠ **⚠ CAUTION ⚠** (See page 62) & (See page 62)

Your recreation vehicle may be equipped a Truma® Combi furnace with supplementary indirect water heating. Refer to the manufacturer's owner manual, for important operating and safety information.

FURNACE (IF EQUIPPED)

⚠ WARNING ⚠ (See page 62)

The furnace installed in your recreation vehicle is controlled by a 12-volt DC thermostat. Depending on your model, there may be up to two thermostats enabling you to control the temperature to your comfort level. The furnace requires both 12-volt power and propane gas for full operation. Make sure you have sufficient power available before operating your furnace.

A qualified RV technician should perform all furnace maintenance at least once a year (more often depending on furnace usage). Never attempt to repair the furnace yourself.

Ducting & Return Air

All heat discharges, registers and return air grills must be free and clear of obstructions. This includes all closeable registers that are intended to reduce airflow, do not shut it off completely.

NOTE

For RV models with touch screens, the furnace controls may be included on the selectable menu screens of the touch screen.

POWER ROOF VENT

The 12-volt DC powered roof vent allows fresh air to circulate through the recreational vehicle. Do not leave the attic fan open when the recreational vehicle is stored or unattended for long periods. High winds, other unusual conditions or obstructions may prevent the dome from closing; the resulting leakage could cause non-warrantable damage.

To use your fan most effectively, close all vents and slightly open a window on a shaded side of your recreation vehicle. You are directing the air flow by opening a window.

The roof vent is controlled by either a switch or touch screen.

For additional safety and operating information, refer to the manufacturer's manual.





FURNACE (See page 61)

The furnace should be inspected periodically (monthly during the heating season) for presence of soot on the vent. Soot is formed whenever combustion is incomplete. This is a visual warning that the furnace is operating in an unsafe manner. If soot is observed on the vent, immediately shut the furnace OFF and contact a qualified service agency. Operating the furnace under this condition could lead to serious property damage, personal injury or loss of life.

To ensure your personal safety, do not obstruct or alter the furnace in any manner. Do not install screens over the vent for any reason. Screens will become restricted and cause unsafe furnace operation. For your safety, only the manufacturer's factory authorized parts should be used on your furnace.

TRUMA® COMBI DIESEL 2 in 1 SYSTEM (See page 61)

Danger of combustion, personal injury and damage to the RV!

- Keep the area around the appliance free from combustible materials, gasoline and other flammable liquids or vapors.
- Switch OFF the appliance and gas supply:
 - If you smell gas
 - If anything appears out of the ordinary
 - If you move the RV
 - Before entering a gas station
 - Before entering a tunnel

Danger of over-temperature and toxic exhaust gases!

- Use with LP gas (propane) only. Butane or any mixtures containing more than 10% butane must not be used.
- Keep the area in front of the warm air outlets free of combustible or heat-sensitive materials. Do not put any material into the warm air outlets.
- Check that furnace vent (and air intake) terminal(s) are not obstructed in any way during all seasons.
- Danger of hot surfaces. The temperature of the exhaust gases can reach 320 °F (160 °C). Do not touch the area around the wall cowl and do not lean any objects against the wall cowl or the RV.
- Shut OFF the Combi furnace when refueling or pumping gas.



HEAT PUMP (See page 60)

Do not operate the heat pump for extended periods of time without the filter installed. Lint, grease, dirt, etc. that are normally stopped by the filter are now accumulating in the cooling coil. This leads to loss of air volume, icing up of the cooling coil, and could result in serious damage to the operating components of the heat pump.

TRUMA® COMBI DIESEL 2 in 1 SYSTEM (See page 61)

Damage to the Combi furnace caused by freezing!

- The Combi furnace does not have a frost-protection function. If the heating is not used and there is a risk of freezing, all water must be drained from the water container
- Water in pipes, faucets and appliances could freeze. Considerable damage may result.
- Before you fill water into appliances and parts that transport water, you must heat the installation area sufficiently so that water cannot freeze.
- No warranty claims are accepted by the manufacturer of the Combi furnace for frost/freeze damage

SECTION 9: APPLIANCES



COOKING SAFETY

In Case Of a Grease Fire

⚠ WARNING ⚠ See page 66)

Grease is flammable. Never allow grease to collect around top burners or on the cook top surface. Wipe up spills immediately. Refer to *Section 2 – Safety Precautions*, for fire safety and fire extinguisher information.

Cooking With Propane (If Equipped)

See the *Propane System* section for important safety instructions. Refer to the manufacturer's owner's manual for detailed operating and safety instructions for all propane appliances.

COOKTOPS, RANGE AND OVEN (IF EQUIPPED)

⚠ WARNING ⚠ ⚠ CAUTION ⚠ See page 66 & See page 66)

For detailed operating and safety information, refer to the manufacturer's user guide.

Cleaning Instructions

Refer to the manufacturer's user guide included for detailed cleaning instructions.

General Cleaning

- To avoid damage and possible burns, be sure the appliance is off and all parts are cool before handling or cleaning.
- Use care to avoid steam burns if a wet sponge or cloth is used to wipe spills on a hot surface.
- Some cleaners can produce noxious fumes if applied to a hot surface.
- To prevent staining or discoloration, clean appliance after each use.
- If a part is removed, be sure it is correctly replaced.

- If a spillover occurs while cooking, immediately clean the spill from the cooking area while it is hot to prevent a tough cleaning chore later. Using extreme care, wipe spill with a clean, dry towel.

Kitchen Range and Oven (If Equipped)

NOTE

To help reduce potential condensation or unwanted cooking odors, turn on the overhead kitchen roof vent or the range hood vent (If Equipped).

To prevent damage, always use the manufacturer's recommended size flat bottom pan(s). Generally, the pan should be large enough to cover the burner, but not be more than one inch larger than the burner grate.

Do not use a broiler pan, griddle or any other large utensil that covers more than one burner at a time. This will create excessive heat that may cause melting, sooting or discoloration.

The use of undersized pans could expose a portion of the heating element to direct contact and may result in ignition of clothing. Proper relationship of pans to burner will improve efficiency.

The propane gas oven must have 12-volt power to operate. **Do not use the oven as a storage area.** If you have any questions, contact your dealer or our customer service department.

Gas Drop-In Cooktops (If Equipped)

Depending on your model, it may be equipped with either a 2 burner or 3 burner cooktop. The 2 burner match-light cooktop has two 6500 BTU/H burners with control panel.

The 3-burner piezo-igniter cooktop has (1) front 9000 BTU/H burner and two rear 5200 BTU/H burners. The 3 burner cooktop is also equipped with a control panel.

Refer to manufacturer's user guide for detailed operating and cleaning information.

APPLIANCES

INDUCTION COOKTOP (IF EQUIPPED)

⚠ WARNING ⚠ **⚠ CAUTION ⚠** (See page 66)

Induction cooktops are more efficient than gas or electric cooktops. The cooking surface heats through magnetic induction. Cookware for induction cooking should be magnetic (steel or cast iron) and have a flat bottom. Cookware made from aluminum, corning ware, Pyrex, or glass will not work by just placing them on the surface, but can be used if they are placed on top of a magnetic interface disk which will function as a conventional hot plate. Stainless steel cookware may or may not work. If there is a doubt as to whether a certain pan or skillet will work, check it with a magnet. If the magnet clings to it, it will probably work with the induction cooktop; if it doesn't or clings weakly it probably won't work.

Induction cooktops are much safer to use than electric or gas.

- The stovetop stays cool, no burned fingers or hands if you touch the surface.
- Only the cooking vessel gets hot.
- The cooking surface only works when there is a magnetic pan (or interface disk) in place on it. Sensors detect the amount of ferrous material in the area of the magnetic field and if it is not the size of a small pan it won't turn on.
- Induction cooktops will not heat up the kitchen.
- Very rapid temperature increases can be achieved and very fine adjustments can be made.

Refer to manufacturer's manual for detailed safety, operating and cleaning instructions.

MICROWAVE

⚠ WARNING ⚠ **⚠ CAUTION ⚠** See page 66 & See page 66)

For details on operation, cleaning and safety information, refer to the manufacturer's user guide.

General Cleaning Microwave and Convection Microwave

IMPORTANT: Before cleaning, make sure all controls are off and the microwave oven is cool. Always follow label instructions on cleaning products.

To avoid damage to the microwave oven caused by arcing due to soil buildup keep cavity, microwave inlet cover, cooking rack supports, and area where the door touches the frame clean.

Clean with mild soap, water and a soft cloth or sponge, or as indicated below.

- Grease filters: mild soap and water or dishwasher.
- Door and exterior: mild soap and water, or glass cleaner applied to paper towel.
- Control panel: sponge or soft cloth and water.
- Stainless steel (on some models): mild soap and water, then rinse with clean water and dry with soft cloth, or use stainless steel cleaner.
- Turntable: mild soap and water or dishwasher.
- Rack(s): mild soap, water and washcloth. Dishwasher cleaning is not recommended.

Convection Microwave (If Equipped)

The convection microwave bridges the gap between microwaving your food and conventional cooking. Make sure there is sufficient 120-volt power before operating the convection microwave (see *Calculating Electrical Load*). For details on operation and safety information, refer to the manufacturer's user guide.

REFRIGERATOR

The refrigerator is not intended for quick freezing or cooling. We recommend stocking it with pre-frozen or pre-cooled food when possible. The shelves should not be covered with paper or plastic and the food items should be arranged so air can circulate freely. Keep the area at the back of the refrigerator clean and free of debris. Check for obstructions in the exterior refrigerator vent area (i.e., spider webs, bird nests, etc.). Use a soft cloth to dust off the debris.

For optimum efficiency and performance, it is recommended the refrigerator be checked at least twice a year as part of the routine maintenance.

For detailed operating and safety information, refer to the manufacturer's user guide.

Cleaning Your Refrigerator

The following are general cleaning guidelines. For detailed information on cleaning your specific refrigerator, refer to the manufacturer's user guide.

Cleaning the Interior

1. Disconnect power.
2. Hand wash, rinse, and dry removable parts and interior surfaces thoroughly. Use a clean sponge or soft cloth and a mild detergent in warm water.
3. Inside the refrigerator, use a warm water and baking soda solution consisting of approximately 1-tablespoon (15ml) baking soda to 1 quart (1 liter) of water. This solution cleans and neutralizes odors. Rinse and wipe dry.
4. Leave an open box of baking soda in the refrigerator and freezer to help prevent odors.

NOTE

Do not use abrasive or harsh cleaners such as window sprays, scouring cleansers, flammable fluids, cleaning waxes, concentrated detergents, bleaches or cleansers containing petroleum products on plastic parts, interior and door liners or gaskets. Do not use paper towels, scouring pads, or other harsh cleaning tools.

Cleaning the Exterior

Painted metal exteriors: wash with a clean sponge or soft cloth and a mild detergent in warm water.

Stainless steel exteriors: wash with a clean sponge or soft cloth and a mild detergent in warm water. Do not use appliance wax, polish, bleach, or other products containing chlorine on stainless steel. Stainless steel can be cleaned with a commercially available stainless steel cleaner. A spray-on stainless steel cleaner works best.

IMPORTANT: Do not allow the Stainless Steel Cleaner and Polish to come into contact with any plastic parts such as the trim pieces, dispenser covers or door gaskets. If unintentional contact does occur, clean plastic part with a sponge and mild detergent in warm water. Dry thoroughly with a soft cloth.

For silver-accented plastic parts, wash with soap or other mild detergents. Wipe clean with a sponge or damp cloth. Do not use scouring pads, powdered cleaners, bleach or cleaners containing bleach as these products can scratch and weaken the paint finish.

LP GAS GRILL HOOKUP (IF EQUIPPED)

⚠ WARNING ⚠ (See page 66)

Gas BBQ Grill Prep

Your recreation vehicle is equipped with a propane “quick-coupler” connection for easy installation of the BBQ grill.

Attaching the “quick coupler” connection

The “quick coupler” is directly connected to the RV propane system. The “quick-coupler” connection is equipped with a positive shut-off valve.

⚠ WARNING
When using this outdoor cooking area:
• The vehicle must be level and stabilized.
• Do not violate manufacturers' instructions on required clearances for cooking appliances during use.
• Do not store cooking appliances until cool to the touch.
Can lead to a fire and explosion and result in death or serious injury. AD-126

Warning Label

NOTE

Outdoor cooking warning label should not be removed from the RV.

Place the “quick coupler handle in the OFF position and push back the sleeve. The valve handle must be OFF to make the connection.

1. Insert the plug and release the sleeve.
2. Push the plug until the sleeve snaps forward, locking the plug into the socket.
3. Turn the handle ON to allow propane to flow to the drop in stove.

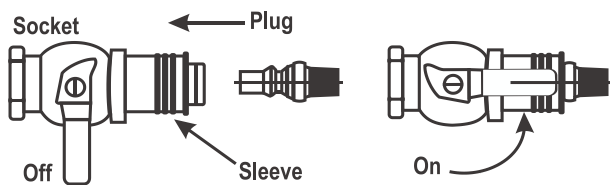

Quick Coupler Connection



APPLIANCES



APPLIANCES DANGER

LP GAS GRILL HOOKUP (See page 65)

Always open the grill lid before turning on gas and lighting burner, failure to open the lid before lighting could cause an explosion causing property damage, injury, or even death.



APPLIANCES WARNING

COOKTOPS, RANGE AND OVEN (See page 63)

During and after use, do not touch or let clothing or other flammable material come in contact with the top burners or heating elements, burner grates or areas near the top burners or oven until they have had sufficient time to cool. These areas can get hot enough to cause burns.

Never leave cooking food unattended. Turn pan handles inward, but not over the tops of the other range burners. Ensure that pans used are large enough to contain the food and avoid boil-overs. Heavy splattering or spills left on the cooktop can ignite and cause burns.

If using glass, glass/ceramic, ceramic, earthenware or other glazed utensils or cookware verify it is safe for use on the top burners.

Do not cover the oven vent openings while the oven is in operation. Restricting the flow of combustion air will create an asphyxiation hazard.

IN CASE OF GREASE FIRE (See page 63)

Do not attempt to use water to put out the fire. Water can spread some types of fire, and electrocution is possible with an electrical fire.

MICROWAVE (See page 64)

Never use the microwave cavity for storage. The microwave cavity should always be empty when not in use.

INDUCTION COOKTOP (See page 64)

Touching a hot pan or cooking vessel can cause burns. Use pot holders or oven mitts to remove hot pans from the cooktop.

LP GAS GRILL HOOKUP (See page 65)

Be sure to read, understand and follow all information supplied with your recreation vehicle concerning the use of propane before operating the BBQ grill. The propane hose must be correctly connected before lighting the grill. Failure to follow instructions supplied by the grill manufacturer, or use of any components other than those originally supplied with the grill, could result in death or serious injury.

If you smell gas: Shut off gas to the appliance, extinguish any open flame and open lid. If odor continues, immediately call your gas supplier or your fire department.

The BBQ grill is intended for use outside of the recreational vehicle. **Never use a gas grill inside a compartment or inside of the recreational vehicle.**

The BBQ grill must be **COMPLETELY COOLED** before storing. Storing the BBQ grill before it is completely cool may result in serious injury or property damage.



APPLIANCES CAUTION

INDUCTION COOKTOP (See page 64)

Aluminum foil should **NEVER** be used with an induction cooktop. It can permanently melt to the cooktop cracking the surface or causing permanent damage.

MICROWAVE (See page 64)

- To prevent damage, remove the turntable from the microwave when traveling.
- Make sure you are connected to a 120-volt power source.

COOKTOPS, RANGE AND OVEN (See page 63)

Never use oven cleaners, chlorine bleach, ammonia, or glass cleaners with ammonia. Always allow the cooktop to cool before cleaning.

SECTION 10: ELECTRONICS



WINEGARD CONNECT 2.0 (IF EQUIPPED)

The Winegard Connect 2.0 is an integrated system that works together for faster speeds and increased range from Wi-Fi sources. It has the following features:

- Nationwide 4G LTE Coverage - Get Internet while on the go! No need to rely on Wi-Fi – the Connect 2.0 4G2 links to nationwide 4G LTE for reliable, uninterrupted, in-motion and stationary coverage while traveling.
- High-Powered Mobile Internet Hotspot - More powerful than smartphone tethering, the Connect 2.0 4G2 provides a stronger and faster 4G LTE Internet connection. Easily connect your computers, gaming systems, smart TVs, and other smart home devices to secure Wi-Fi in seconds.
- Increased Wi-Fi Range - Winegard's smart antenna technology intelligently manages signals through multiple pathways to ensure better range and performance. The Connect 2.0 4G2 roof-mounted mobile hotspot/Wi-Fi booster allows you to access Wi-Fi signals in your RV from farther away!
- Cellular Data Carrier Options - The Connect 2.0 4G2 is compatible with Winegard, AT&T, Verizon, and T-Mobile cellular Internet service providers. Swap SIM cards to add to new or existing data plans from other carriers. The Connect 2.0 4G2 comes ready for use out of the box, preinstalled with a unique Winegard SIM card. If you choose to use your own 4G LTE plan, easily swap out the existing SIM card with an approved SIM card supplied by your cellular provider.
- Secure RV Internet - Advanced Wi-Fi protected access (WPA and WPA2-PSK), guest network access, double firewall protection (SPI and NAT), and Denial-of-Service (DoS) attack prevention.

For operation of the system, turn on the rocker switch to the 'ON' position. It will enable device(s) that you want to connect and scan for wireless networks.

Refer to the manufacturer's user guide for detailed information on set up and using the system.

SECTION 11: INTERIOR



CLEANING THE INTERIOR

⚠ CAUTION ⚠ (See page 73)

To keep the value of your recreation vehicle, perform regular maintenance using the proper materials and procedures. Using the wrong cleaner may result in damage to the surfaces in your vehicle. Check with the manufacturer's information for the recommended cleaning agent. If in doubt, check to see if the cleaner will cause damage by testing a small area out of sight or contact your dealer for assistance. Do not use flammable liquids or sprays to clean the recreation vehicle.

Furniture Upholstery: Vacuum the furniture upholstery regularly using a soft brush attachment to remove any loose dirt or debris.

Fabric: It is recommended the fabric be professionally cleaned if it becomes stained or soiled. The professional cleaner should be made aware the fabrics that may have been treated to be fire resistant. For more information, refer to the specific furniture manufacturer's care instructions.

Leather (If Equipped): Periodic vacuuming, using a dry cloth to wipe up spills immediately, and using a damp cloth on problem areas, will help to keep your leather furniture in good condition. Leather surfaces can vary, as do the cleaning methods. Refer to the furniture manufacturer's recommendation, or consult a cleaning professional.

It is recommended you do not use any cleaners containing oils, waxes or silicones. Cleaners containing silicone can eventually destroy the finish on the leather. Cleaners containing oils or waxes should not be used as they leave residues on the surface of the leather, which can attract more dirt and eventually lead to cracking.

Window Shades

Shades should be vacuumed periodically to remove dust. Using your vacuum cleaner's upholstery brush on low suction will remove most dust and dirt from the shade. Refer to the shade manufacturer's owner's manual for additional and detailed information.

To remove stuck on dust or stains refer to the following guide.

Solar Shields: Use a sponge or soft brush and water to remove stains. A mild cleaning solution can be used to remove tougher stains.

Rinse after cleaning by wetting a clean cloth in fresh water, wringing out any excess and wiping the areas where the cleaner was used.

Day/Night Shades: Clean with a mild cleaning solution using a sponge or paper towel. Wipe down with water after cleaning and dry thoroughly before raising the shade. Do not use spot remover, household cleaners or detergents to remove soiled spots, as these may cause damage to fabric or loss of color from fading.

Mini Blinds: A simple dry rag may do the trick. If they are especially dirty, you can use cold or warm water to clean them; **never use hot water.**

Fill a spray bottle with water and a tiny amount of soap. Then spray a lint-free towel with the mixture and use the towel to wipe down each slat. While cleaning, try not to bend the slats. They can also be soaked in a bathtub to loosen up any debris so the slats can be wiped down easily.

NOTE

If your recreation vehicle must be stored for an extended period, store shades in the up position and cover your windows with additional protection (I.E. cut out cardboard).

Cabinetry and Tables

To keep hardwood doors, cabinet fronts and hardwood tables looking like new regularly dust with a soft cloth dampened with a cleaning polish or mild detergent solution. Avoid using ammonia based products or silicone oils as they may cause damage if used over a long period of time.

The finish is durable and resistant to most household spills. However, spills should be wiped up promptly to avoid potential problems.

Excessive prolonged exposure to direct sunlight, high temperatures and high humidity can cause damage to both the finish and the wood itself.

Interior Wall Panel

To clean, use a mild solution of soap and lukewarm water with a soft sponge or cloth. Wipe dry with a soft, clean cloth.

Putty sticks can be used to cover scratches on the wood surface wall panels. These can be obtained from local hardwood stores and lumberyards. Contact your dealership service department for assistance in repairing décor paneling.

ABS Plastics

Dust and wipe clean with soft, damp cloth or chamois, wiping gently. Do not use gritty or abrasive particle soaps or scouring compound to clean ABS plastic. Avoid using "citrus" or biodegradable cleaners that contain "D-Limonene" as they may damage plastic materials.

SOFA AND DINETTE (IF EQUIPPED)

⚠ WARNING ⚠ (See page 73)

Your RV may be equipped with one of the following sofa styles.

Hide-a-Bed Sofa or Sofa Sleeper

To make the hide-a-bed sofa into a bed, remove the seat cushions and pull the strap located at the front of the sofa seat bottom out towards you firmly and gently. To convert the hide-a-bed back into the upright sofa position, reverse the process (make sure to pull the seat belts out into their usable positions). Be sure to hold the sofa strap firmly to ensure the hide-a-bed sofa does not suddenly drop shut. Refer to the furniture manufacturer's care instructions for this product.

Jack Knife or Easy Bed Sofa

The easy bed sofa should comfortably seat two to three adults. It converts to a bed by lifting at the front of the sofa seat section and pulling it towards you. The sofa back will follow and pivot down into a horizontal position. To reconvert back to an upright sofa, reverse the process (make sure to pull the seat belts out into their usable positions). Refer to the furniture manufacturer's care instructions for this product.

Free Standing Dinette Chairs (If Equipped)

⚠ WARNING ⚠ (See page 73)

Two free standing chairs and two folding chairs are included in the free standing table/chair package. When traveling in the motor home, the free standing chairs should be fastened securely at the dinette table, and the folding chairs be secured in a closet or storage area.

CEILING FABRIC

The ceiling fabric is made from padded vinyl fabric. Wash with mild detergent and water. Use a soft bristle brush for stubborn soil. Rinse and dry. Some household cleaners and solvents remove plasticizers from vinyl, making them brittle. Abrasive cleaners may mar or scratch the surface. Always test a small hidden area before applying cleaners to the vinyl surface.

Trifold Sofa

The trifold sofa offers very similar features to a traditional hide-a-bed. The following illustrations detail converting the sofa into a bed.

1. Remove the tri-fold sofa pillows and set aside.
2. Using the strap handle, pull the sleeping surface up, then out.
3. While sleeping surface is up, fold out legs. Extend the sleeping surface until grounded.
4. Once sleeping surface is grounded, fold head board down flat.



Dinette Table

Depending on your model, the dinette table can be extended by standing at the end of the table, firmly holding both sides of the table, and pulling the table towards you. To return the table to the stowed position, reverse this process pushing it in until the table locks in place.

Booth Dinette (If Equipped)

The booth dinette can be converted to a bed by lowering the tabletop to make the bed base.

To Convert Dinette To A Bed:

1. Remove the cushions from the dinette.
2. Grasp the table top at the rounded end, and lift the rounded end up at an angle (A).
3. The table top will separate from the bracket attached to the wall.
4. Pull the table top away from the wall, toward you slightly.
5. Lower the table top down between the seats (B).
6. Place the extra cushion on the table top between the 2 seats.
7. Replace the seat cushions.

To Convert Back To A Table:

1. Remove cushions.
2. Lift table top back up to the bracket.
3. Hold the table top at an angle (A).
4. Push the table top back toward the wall.
5. Bracket should latch, put the table top to a level position.

COUNTERTOPS

To prevent permanent damage

- Always use hot pads or trivets under hot pans, dishes, or heat producing appliances.
- Heat will damage countertops.
- Use a cutting board to prevent unnecessary damage to the countertops. Do not cut directly on the countertop.
- Avoid harsh chemicals such as drain cleaners, oven cleaners, etc.
- Do not let cleaners with bleach set on the top. Wipe them off promptly.
- Run cold water when pouring hot/boiling water into the sink.
- Use coasters under all glasses, bottles and cans.
- Do not store toiletry products directly on your countertop surface. Hair products, perfumes, colognes, nail products, creams, lotions and potions have a tendency to spill or leak and go overlooked. Even though the counter top is sealed, a substance that remains on the surface for an extended period may stain the countertop.

For additional information on the removal of difficult stains or surface damage repair, refer to the countertop manufacturer's user guide.

Solid Surface Countertops

Soapy water, ammonia based cleaners (not window cleaners as they can leave a waxy build up that may dull the surface) or commercially available solid surface cleaners will remove most dirt and residue from all types of finishes. A damp cloth followed by a dry towel will remove watermarks.

Difficult stains can be removed from the matte finish with a green Scotch Brite® pad and a mild abrasive cleaner. Disinfect the surface periodically with diluted household bleach (one part water to one part bleach).

For cuts and scratches, sand the matte finish lightly with (220) fine grit sandpaper until the cut or scratch is gone. Restore finish with a green Scotch Brite® pad and mild abrasive cleaner.

Solid surface sink maintenance

Occasionally, clean the solid surface sink by filling one-quarter full with a 50/50 water/bleach solution. Let soak for 15 minutes, and then wash sides and bottom of sink as solution drains.

Laminate Countertops

Glass rings, food spills, water spots and smudges usually wipe off with a damp sponge. All stains must be cleaned immediately, especially oil and food splashes. Any mild and non-abrasive household detergent can be used, however micro-fibre cloths are recommended for high-gloss laminates to minimize the risk of scratching the surfaces. Dry all surfaces if it is wet after cleaning.

If a stain persists, use a paste of baking soda and water and apply with a wet sponge. Light scrubbing for 10 to 20 strokes should remove most stains. Although baking soda is a low abrasive, excessive scrubbing or exerting too much force could damage the decorative surface, especially if it has a gloss finish.

FLOORING

Vinyl Flooring

Periodically vacuum or sweep to remove dirt and gritty particles. Although most common spills will not permanently stain the vinyl floors, they are usually easier to remove if wiped up before they set. Blot with a paper towel and wipe clean with a damp cloth. Do not use dish detergents or vinegar and water because they will dull your floor.

To care for the vinyl floor covering, use a damp mop with water and a mild cleaner on the entire floor. DO NOT SOAK THE FLOORING. Use care to avoid wetting the carpet edges. To avoid problems of "yellowing" linoleum, the flooring manufacturer recommends avoiding cleaners that contain oil based solvents (i.e. lemon oil, Murphy's Oil Soap, etc.).

FLOORING TOP SEAL

The linoleum floor is equipped with a factory-applied urethane finish. No additional finishes are required, and applying any additional finishes is not recommended. For detailed care and maintenance information, refer to the manufacturer's user guide.

Routine/Daily Maintenance

- Remove all gross soiling (food, gum, residues, etc.). Take care if using a scraper or putty knife to avoid permanently damaging the surface of the flooring.
- Clean the flooring using a microfiber dust mop. If necessary, vacuum the floor to first pick up any large particles.
- Apply a properly diluted neutral cleaner to the surface using a microfiber wet mop pad.
- If necessary, use clean water and a clean microfiber mop pad to remove any remaining residue.

Periodic Maintenance

- Remove all gross soiling (food, gum, residues, etc.). Take care if using a scraper or putty knife to avoid permanently damaging the surface of the flooring.
- Clean the flooring using a microfiber dust mop. If necessary, vacuum the floor to first pick up any large particles.
- Using a properly diluted neutral pH cleaner, scrub the floor with a red buffing pad on a slow speed (175 – 300 RPM) rotary floor machine or auto-scrubber, vacuuming up any remaining cleaning solution.
- If necessary, use clean water and a clean microfiber mop pad to remove any remaining residue.

THIRD SEAT AND TABLE(S)

 **WARNING**  **CAUTION**  (See page 73) & (See page 73)

Your motor home may be equipped with a seat for additional passengers. This seat is adjustable to the front and side.

Removable Table

The small table can be removed and stored if desired. When installing the table pedestal, make sure it is securely seated and latched in the mounting hole.

Side Table (If Equipped)

The side table (accessed through the sliding door) can be released at the top and lowered into place. The table is secured in place by the mounting hinge and by the adjustment cable. If the motor home is parked on an incline, the cable can be adjusted and secured so the table surface is level.

Table Tops

To prevent permanent damage

- Always use hot pads or trivets under hot pans, dishes, or heat producing appliances.
- Heat will damage table tops.
- Use a cutting board to prevent unnecessary damage to the table tops. Do not cut directly on the table top.
- Avoid harsh chemicals such as drain cleaners, oven cleaners, etc.
- Do not let cleaners with bleach set on the top. Wipe them off promptly.
- Run cold water when pouring hot/boiling water into the sink.
- Use coasters under all glasses, bottles and cans.
- Do not store toiletry products directly on your table top surface. Hair products, perfumes, colognes, nail products, creams, lotions and potions have a tendency to spill or leak and go overlooked. Even though the counter top is sealed, a substance that remains on the surface for an extended period may stain the table top.

Glass rings, food spills, water spots and smudges usually wipe off with a damp sponge. Stubborn stains can be removed with a general-purpose spray cleaner. Some stains can be removed by squeezing fresh lemon juice over the stain and allowing the juice to soak for approximately forty-five minutes. After 45 minutes, sprinkle baking soda over the lemon juice and rub with a soft cloth.

For additional information on the removal of difficult stains or surface damage repair, refer to the table top manufacturer's user guide.

POWER BUNK BED (IF EQUIPPED)

Your motor home may be equipped with a power bunk bed.

Refer to the manufacturer's user guide for important safety, operating and maintenance information.

NOTE

Any adjustments to the bed should only be made by a Qualified Technician.

Operation

To operate the bed, turn the key switch to the on position. Press the UP or DOWN arrow button. A green LED light will light up indicating the bed direction. The bed will continue to move until



- The switch is released.
- A pre-set stop position is reached.
- The bed is being lifted and the end-of-stroke position is reached.

When upper bunk is positioned where you want it, turn the key to the OFF position.

You should adhere to the following safety information:

- Safety devices shall not be tampered with for any reason.
- Before starting the vehicle engine and driving, always make sure the bed lifting system is in its highest position and the safety belts are fastened. **Refer to the manufacturer's guide for important safety belt information.**
- The bed lifting system shall only be used by adult and responsible staff.
- It is forbidden to use the bed lifting system while the vehicle is running.
- It is forbidden to start the bed lift system manually with disconnected wires from motor unit to control unit.
- Should the mechanism not work, do not use the bed and ask for assistance at the next service center.



BUNK BEDS AND BUNK LADDERS (IF EQUIPPED)

⚠ WARNING ⚠ (See page 73)

Your recreational vehicle may be equipped with bunk style beds. Bunk bed weight ratings may vary depending on your model and the style of bunk bed. Weight capacities are listed on the bunk capacity label. Do not exceed the bunk weight capacity.

Cab-Over Bunk Bed

Your motor home may be equipped with an over-the-cab bunk bed. This bunk bed is accessed through the use of a steel ladder that hooks to the bed platform.

Bunk Ladders (If Equipped)

Your recreational vehicle may be equipped with a ladder to access the upper bunk. This ladder may be a separate steel ladder, or a wooden ladder attached to the bunk beds.

The top of the ladder is secured to the ladder storage compartment. To operate the ladder, lift up and out of the storage tray. Pivot the bottom of the ladder out. Be sure the ladder is securely in place on the floor before climbing to the upper bunk.

When storing the wood ladder, place the bottom of the ladder back into the tray in the storage compartment. This keeps it secure during transport and clear of walkways.

The steel ladder (if equipped) will simply hook onto the upper bunk.



NOTE

Some types of bunk beds do not include a ladder.



 **WARNING** 

BUNK BEDS AND BUNK LADDERS (See page 72)

- Exercise extreme care when entering or exiting the bunk beds and using the ladder.
- Do not allow more than one person on the top bunk.
- Do not allow children under 6 years of age to use the upper bunk.
- Do not allow horseplay on or under the bed and prohibit jumping on the bed.
- Make sure the ladder is anchored properly to the bed.
- Never allow more than one person on the ladder at a time.
- Children should always be supervised when using the ladder or when entering or exiting the bunk beds.
- Weight limit of the bunk ladder is 300 lbs. (136 kg). Never exceed this weight.
- Maximum weight limits for bunk beds will vary depending on model or bunk style. **Never exceed the maximum weight specified on the bunk capacity label.**
- Failure to follow these instructions can result in serious bodily injury.

SOFA AND DINETTE (See page 69)

Always use seatbelts if sitting in the sofa or dinette while the motor home is in transit.

FREE STANDING DINETTE CHAIRS (See page 69)

Do not allow occupants to occupy the free standing dinette chairs while the motor home is in transit.

THIRD SEAT AND TABLE(S) (See page 70)

Do not sit on or lean on the table(s). They are intended for use as a table only

 **CAUTION** 

CLEANING THE INTERIOR (See page 68)

Do not use abrasive cleaners as they may cause the vinyl to scratch and become dull. Do not use cleaners that contain bleach.

INTERIOR WALL PANEL (See page 69)

Do not use abrasive cleaners as they may cause the vinyl to scratch and become dull. Do not use cleaners that contain bleach.

THIRD SEAT AND TABLE(S) (See page 73)

Always use seatbelts if sitting in the third seat while the motor home is in transit.

SECTION 12: EXTERIOR



CLEANING THE EXTERIOR

To protect your recreation vehicle's exterior finish, wash it often and thoroughly. You may wash and wax your new recreation vehicle 60 days after purchase. The exterior paint needs time to cure before any wax is applied to the exterior surface. Careful maintenance for the first 60 days will assure a long lasting durable finish.

Your RV is exposed to many environmental conditions that have an adverse affect on the paint finish:

- Road Salt and Sodium Chloride
- Road Tar / Bugs
- Bird Droppings / Tree Sap
- Industrial Fallout / Acid Rain/Pollution
- UV Exposure and Moisture

The most common problems resulting from these conditions are corrosion, staining, and chemical spotting. Generally, the longer the foreign material remains in contact with the exterior finish the more extensive the damage. These problems can be minimized by regularly scheduled washing and polishing. Wash your recreation vehicle as soon as possible if it becomes contaminated with foreign material.

Avoid parking under trees or near ocean sea salt. Ice or snow should be brushed off, not scraped, from the painted surface. Avoid gravel roads.

Anti-freeze, gasoline or washer solvents if spilled on the painted surface should be rinsed off with water immediately. Bugs and bird droppings should be rinsed off daily.

Washing

Commercial washing should be avoided. Wash with cold water using a mild liquid soap. Dry wiping with a dry cloth is not recommended.

Make sure the RV's surface temperature is cool, under 90 F, and out of direct sunlight. A shaded area is ideal for washing your vehicle as direct sunlight causes water spotting. Use a mild soap, detergent or car wash shampoo. Try to avoid combination wash-n-wax products as these waxes can cause build up and are designed for smaller surfaces. Have two dedicated sponges or wash mitts: one for the paint finish and one for the wheels and under carriage. Brushes or wash mitts made of plastic bristles are acceptable for use on tires and wheel wells, but are not intended for use on the paint finish. Avoid using such items on painted surfaces as they will damage the finish. Wash the wheels and wheel wells first as this removes heavy dirt and debris and prevents it from splattering on panels. Wet the entire area down to remove loose dirt and grime, then hand wash one area at a time using your dedicated paint finish sponge or wash mitt. Wash from the top and work your way down, rinsing frequently to minimize grit abrasion. Follow with a final rinse of water. This process will remove most contamination from the RV's surface.

For stubborn stains such as road tar or bug stains, use an ammonia based glass cleaner or a small amount of rubbing alcohol on a damp cloth followed immediately by warm soapy water, and rinse with clean water. This may not dissolve the road tar, but it will loosen tar and bug stains and remove them from the surface.

Do not use solvent based cleaners on bird droppings or tree sap as these are water based stains. They can be dissolved using ammonia based glass cleaner, warm soapy water and a little "elbow grease". After removing stubborn stains immediately rinse with clean water.

Drying the RV is just as important as washing it. Tap water and well water contain many chemicals that could water stain your RV's finish.

We suggest using a damp natural or synthetic chamois. Other drying products such as lint-free micro-fiber towels that work just as well.

During Cold Weather

Salt and other chemicals that are spread on winter roads in some geographical areas can have a detrimental effect on the recreation vehicle's underbody.

If your recreation vehicle is exposed to these conditions, spray the underbody with a high-pressure hose every time you wash the exterior of your recreation vehicle.

Take special care to remove mud or other debris that could trap and hold salt or moisture. After washing your recreation vehicle, wipe off all water drops from the rubber parts around the slideout and doors.

NOTE

When the slideout or door is frozen, opening it by force may tear off or crack the rubber gasket that is installed around the slideout or door. Pour warm water on the gasket to melt the ice (wipe off the water thoroughly after opening the slideout or door). To prevent the weather stripping from freezing, treat it with a silicone spray.

Waxing

CAUTION (See page 77)

Wax your recreation vehicle once or twice a year, or when painted surfaces do not shed water well. Use a soft cloth to apply a small amount of wax to the painted surfaces. After the wax has dried, polish the recreation vehicle with a dry, soft cloth.

Do not wax your recreation vehicle in direct sunlight. Wax it after the surfaces have cooled. Do not apply wax to any area having a flat black finish as it can cause discoloration. If the finish has been stained with wax, wipe off the area with a soft cloth and warm water. When waxing the area around the various openings, do not apply any wax on the weather strip. If it is stained with wax, the weather strip cannot maintain a weatherproof seal around the opening.

Polishing Your Recreation Vehicle

If painted surfaces have been severely damaged and have lost their original luster and color tone, polish the surface lightly with a fine polishing compound. Avoid limiting your polishing to the damaged surface only; polish a somewhat wider area, moving the polishing cloth in one direction. After polishing, flush the compound from the surface and apply a coat of wax to regain a beautiful luster.

Damaged Paint

To prevent corrosion, touch up small cracks and scratches in the paint coat as soon as possible with touch-up film or paint. Carefully check the body areas facing the road and the tires for damage to the paint coat caused by flying stones, etc.

Cleaning Plastic Parts

CAUTION (See page 77)

Use a sponge or chamois to clean plastic parts. Use warm water and a soft cloth or chamois to remove any white residue from dark colored plastic surfaces. Do not use a scrubbing brush, other hard tools, or wax containing abrasives as they may damage the plastic surface.

Chrome Parts

To prevent chrome parts from spotting or corroding, wash with water, dry thoroughly, and apply a non-abrasive automotive wax. If the chrome is severely damaged or pitted, use a commercially available chrome polish product.

FRAME

Frames receive heavy abuse from road conditions such as sand, pebbles, objects in the highway, and/or ice inhibiting chemicals, all of which will cause chipping and a blasting effect on the painted surface. Frames will show signs of rust much sooner when exposed to salty air. Periodically rinse off the frame (or as use requires) removing road grime, tar, oil, mud or salt.

Refer to your Chassis Guide for the chassis manufacturer's maintenance instructions.

FIXED EXTERIOR LADDER (IF EQUIPPED)

WARNING (See page 76)

Your recreation vehicle may be equipped with an exterior roof ladder. **Refer to the manufacturers User Manual for important use and safety details.**

EXTERIOR HOOKED LADDER (IF EQUIPPED)

WARNING (See page 76)

Your recreation vehicle may be equipped with an exterior roof ladder.

The exterior ladder is stored on the back of the motor home. When it is in the stored position, make sure it is securely fastened and locked in place while in transit.

To use the exterior ladder, unlock and remove the handle securing it to the vehicle. Lift up and remove it from the storage bracket. Hook the top of the ladder to the (driver's side) roof rack rail. The ladder can be hooked at any location on the rail. Be mindful of placing the ladder against storage doors, windows or other components that may be damaged. Do not exceed the weight limit of the ladder.

EXTERIOR ROOF AND SIDEWALL VENTS

Inspect the roof vents, including sealants for cracks and keep them clean. Inspect the holding tank vents for blockages from bird nests, spider webs, leaves, etc. All exterior access doors and vents need to be kept clean and free of obstructions (i.e., insect nests, mud daubers, etc.) while the appliances are in use.

WINDOWS

WARNING (See page 76)

Any ventilating window may permit water inside, especially during heavy rainstorms or while driving. This is normal and water should only be seen in the lower track portion of the window frame.

Condensation will also cause water to accumulate on windows and in the tracks. Ensure that the escape window latches are properly adjusted (the window will pop open if not adjusted tight enough).

EXTERIOR

Window Glass

The window glass can normally be cleaned with a sponge and water. Use glass cleaner to remove wax, oil, grease, dead insects, etc. After washing the glass, wipe it dry with a clean, soft cloth.

SEALANTS



(See (See page 77))

Sealants perform a very important function and should be inspected closely and regularly maintained. We incorporate many different types of sealants, including butyl/putty, black butyl-encapsulated foam, silicone (clear and colored), roof sealant and foam. In general, sealants do not have "set" lifetimes. Varying environmental factors affect the pliability and adhesiveness of sealants.

You Or Your Dealer Must:

- Inspect all sealants, a minimum of every six months. Make sure to check the roof and all four sides of the recreation vehicle including all moldings, doors, vents and exterior attachments. A quick walk around the recreation vehicle before leaving may help prevent potential problems during trips and vacations.

- Have the sealant replaced if you notice any cracks, peeling, voids, gaps, breaks, looseness or any sign of physical deterioration. Reseal at least one time each year as preventative maintenance.
- Always use the same type of sealant that was removed. Your dealer service or parts manager can help you obtain the correct sealant(s).

The sealants may become damaged due to road vibration, ultraviolet exposure, air pollution, freezing temperatures and exposure to other elements. Repair deteriorated sealants immediately to prevent damage. Cap seal all trim and openings at least once after the first year and thereafter as cracks, peeling, lifting and shrinkage occur.

If you notice water inside the recreation vehicle, immediately have the dealer check for the source of the leak. Failure to correct the leak may result in serious damage to your recreation vehicle, and this damage may not be warrantable.

If you have questions and/or need assistance with sealing your recreation vehicle, consult with your recreation vehicle dealer.



EXTERIOR WARNING

WINDOWS (See page 75)

To avoid exhaust gas entry into the motor home, keep windows closed when the chassis or generator engines are running.

FIXED EXTERIOR LADDER ((See page 75)

- Do not leave items attached to the ladder while traveling. DO NOT exceed the weight rating of the ladder. The ladder weight capacity label is located under the bottom step of the ladder. There should never be more than one person on the ladder at the same time.

LADDER CAPACITY MAXIMUM 300 lbs. (136 kg)

- **DO NOT** exceed the ladder maximum weight rating.
- The maximum rating includes the person's weight **PLUS** weight of items carried.
- When climbing:
 - Always face the ladder.
 - Climb slowly with weight centered between side rails.
 - Keep a 3 point contact on the ladder at all times (3 Point contact-two hands and a foot or two feet and one hand).
- Keep hands free.
 - Use of accessories such as lanyards to keep carried items tethered will keep hands free and prevent falling items.
 - Heavy or bulky items should be brought up only after reaching the roof.
- Do not use the ladder if damaged in any way.

Failure to follow these guidelines could result in death or serious injury.

**EXTERIOR HOOKED LADDER (page 71)****LADDER CAPACITY MAXIMUM 225 lbs. (102 kg)**

- **DO NOT** exceed the ladder maximum weight rating.
- The maximum rating includes the person's weight **PLUS** weight of items carried.
- Maximum of 1 person on the ladder.
- When climbing:
 - Always face the ladder.
 - Climb slowly with weight centered between side rails.
 - Keep a 3 point contact on the ladder at all times (3 Point contact-two hands and a foot or two feet and one hand).
- Keep hands free.
 - Use of accessories such as lanyards to keep carried items tethered will keep hands free and prevent falling items.
 - Heavy or bulky items should be brought up only after reaching the roof.
- Do not use the ladder if damaged in any way.

Failure to follow these guidelines could result in death or serious injury.

**EXTERIOR CAUTION****WAXING ((See page 75))**

- Do not use waxes containing high-abrasive compounds. Such waxes remove rust and stains effectively from the paint work, but they are also harmful to the luster of the painted surface since they scrape off the coating. Further, they are detrimental to glossy surfaces, such as the grille, garnish, moldings, etc. Do not use gasoline or paint thinners to remove road tar or other contamination to the painted surface.
- Do not use a buffer and a buffing compound as it may damage the exterior surface. Please contact a professional paint body shop for assistance.

EXTERIOR LADDER (page 71)

- The ladder should never be used to climb while in the stored location/position. Climbing the ladder while stored may result in damage to the vehicle rear doors.
- The ladder is provided for limited access to the roof.

CLEANING PLASTIC PARTS ((See page 75))

Do not allow plastic to come into contact with brake fluid, engine oil, grease, paint thinner, or battery acid. These will damage plastic. Use a soft cloth and a mild detergent solution to wipe away any such contact.

SEALANTS ((See page 76))

- Failure to properly maintain or reseal your recreation vehicle may result in serious water damage to the roof and other parts of the recreation vehicle. This damage is not covered by the **Limited Warranty**.
- To check the exterior sidewall sealants, use a stepladder placed safely alongside the vehicle. Do not prop a ladder against the body of the RV as it may damage the exterior finish.

SECTION 13: CHECKLISTS



MOTOR HOME STORAGE

Properly preparing your motor home for storage during periods of non-usage will prevent problems from arising. It will also make it easier to get started again for the following camping trip or season. To prevent costly freeze-ups, winterize the plumbing system when it will not be in use for an extended period of time, especially if it is stored in colder climates.

Prior To Storage:

- Prepare the chassis for storage in accordance to the Chassis Guide. Remember to use fuel additives and supplements if recommended.
- Wash and wax the exterior of the vehicle. Do a sealant inspection and repair as necessary.
- Inspect and clean tires. Check for wear, cracks and inflation pressure.
- Inspect and seal off any area that offers an entry point for rodents, birds or insects. Cover all external outlets (i.e. furnace, vents etc.). Damage from birds, rodents, insect, etc., is not covered under the "Motorized Transferable Limited Warranty" applicable to your motor home.
- Close all windows, roof vents and range hood vent.
- Turn the furnace thermostat(s) to the OFF position (if equipped).
- If your motor home is equipped with a gas/electric DSI range, light a range gas burner to consume any gas remaining in the lines. Once the flame extinguishes itself, turn the burner valve OFF.
- Drain all water lines. Make sure the motor home is winterized.
- Winterize the toilet and appliances (dishwasher, refrigerator, clothes washer).
- Drain and flush all holding tanks (fresh water, gray water, black water and/or hot water tanks).
- Adding fuel stabilizer to the generator will aid in preventing condensation and fuel varnishing.
- Turn OFF the motor home 12-volt battery disconnect switch.
- Turn OFF the inverter mode at remote.
- Disconnect the batteries to prevent battery discharge.
- Remove all perishables from the refrigerator/freezer. Defrost, wash and dry the interior of the refrigerator/freezer and prop (or block) the doors open so air can circulate and prevent mildew.
- Remove all perishables from the cabinets. Leave the cabinets and doors ajar to allow air circulation and prevent mildew and musty odors.
- Lubricate locks and hinges on exterior doors.

CHECKLISTS

While The Motor Home Is Being Stored

If the vehicle is stored outside in areas of heavy snow, you should periodically brush the snow off to prevent excessive accumulation and prevent possible roof damage.

TRAVEL CHECKLIST

Following is a preliminary list of items that need to be checked before leaving your home or campsite. This is a general list, which you may want to customize as you determine your own needs. Refer to your Chassis Guide for information on chassis pre-trip inspections and maintenance.

Safety

- Make sure you follow all safety precautions noted in this owner's manual and in any manufacturer's operators manual when preparing to travel.

Before Leaving Home:

- Make sure all fluids are at proper levels (engine oil, transmission fluid, engine coolant, power steering fluid and windshield washer fluid).
- Check the fuel gauge and lights on the motor home. **Have someone observe the operation of all exterior lights while you activate the controls. Check the turn signal and high beam indicators on the instrument panel.**
- Examine the tires for excessive tread wear or uneven wear patterns. Check for stones, nails, glass or other objects lodged in the tread. Inspect for tread cuts or sidewall cracks.
- **Check tire pressure and correct according to manufacturer specifications.**
- **Check wheel nuts for tightness.**
- Inspect and work all interior and exterior latches and locks and lube if necessary.
- Make sure the batteries are fully charged and installed correctly.
- Turn ON the motor home 12-volt battery disconnect switch.
- Inspect the power cord and carefully clean the contacts if necessary. Plug in the power cord to an appropriate power source.
- Turn on the interior lights and check outlets for polarity. If needed, replace any blown fuses. Check the circuit breakers and test the GFCI circuits.
- **Inspect and turn on the propane gas system** (if equipped). If you have any questions, contact your independent dealer or a qualified propane gas service representative for assistance. If the propane system is functioning properly, test any pilot lights or direct spark ignition features. Turn off the propane when finished.
- **Inspect and test all safety detectors.** If needed, replace any drained or discharged batteries. If you have a defective or damaged safety detector, replace it immediately.

- Inspect the leveling jacks for operation. If needed, perform maintenance as per the manufacturer's information.
- Test all exterior and interior lights. Replace any bulbs that are burnt out.
- **Prepare the chassis portion of the motor home for the camping season in accordance with the Chassis Guide.**
- Wash the exterior of the motor home. Do a sealant inspection and repair as necessary.
- De-winterize and sanitize system.
- **If you are towing a vehicle, connect it to the motor home and test all connections and lights (if applicable).**
- **Test brakes for proper operation.**
- Fill the fresh water tank. Disconnect, drain and store the garden hose on the bracket.
- **Check the seat belt buckles and release mechanisms for positive action and secure connections.**

Before Leaving The Campsite:

- Check the area under the motor home after overnight parking and look for fuel, water, oil or other fluid leaks. If leaks are detected, find the cause and correct it immediately.
- Turn off propane tanks (if so equipped).
- Empty black and gray holding tank, rinse as needed.
- Retract any awnings and secure them for transport.
- Close all the roof vents.
- Close windows and latch blinds.
- Disconnect the cable TV and phone hookups and lower the TV antenna.
- Turn off the interior lights, water heater, furnace and water pump.
- Secure any loose, heavy or sharp objects in the motor home or exterior compartments.
- Disconnect the power cord and ensure it is stored correctly.
- Disconnect any water connections.
- Water pump and water heater (if applicable) turned off.
- Fasten all interior and exterior doors securely; lock them (if applicable). Latch drawers, cabinets and doors.
- Move slideout(s) in and lock it in place (if applicable).
- Walk around your motor home one last time to make sure everything is stored away and the baggage compartments are closed and locked.
- Refrigerator door locked.
- Furnace turned off.
- Make sure the leveling jacks are retracted to the travel position.
- Retract step.
- Secure and lock the entrance door.

SECTION 14: ADDITIONAL INFORMATION



HELPFUL LINKS

Disclaimer: These links are being provided as a convenience and for informational purposes only; they do not constitute an endorsement by Entegra Coach, Inc. or any of its subsidiaries regarding any of the products, services, or opinions contained within. Entegra Coach, Inc. bears no responsibility for the accuracy, legality or content of the external site or for that of subsequent links. Contact the external site for answers to questions regarding its content.

CLUBS & ORGANIZATIONS

FMCA

fmca.com

The FMCA educates, equips, and empowers RV owners in their journey to creating, experiencing, and benefiting from the outdoor lifestyle they dream of and deserve. All motorized and towable RVs welcome.



Good Sam Club

goodsam.com

Part of the RV community since 1966, Good Sam was founded on the idea of being good, doing good, and helping others. With over 2 million Good Sam Members and over 2100 Good Sam Parks and campgrounds, Good Sam makes it easy to travel and connect. Good Sam also offers a full suite of protection products including insurance, roadside assistance, extended service plans, and more.



Harvest Hosts

harvesthosts.com

Harvest Hosts is an RV membership program that provides unlimited overnight stays at thousands of locations nationwide such as farms, breweries, wineries, and much more. New members save 20% off of their first year of membership with the code JAYCO20.



Passport America

passportamerica.com

Passport America is a discount membership club that provides half price camping to a network of Over 1,200+ quality campgrounds and RV parks throughout the U.S., Canada and Mexico.



TRAVEL RESOURCES

Bring Fido

bringfido.com



Explore over 500,000 places to stay, play, and eat with your dog.

U.S. Dept. of Transportation

fhwa.dot.gov/trafficinfo/index.htm

Federal Highway Administration's National Traffic and Road Closure Information



National Weather Service

weather.gov/alerts

National Weather Service Weather Alerts



Roadtrippers

roadtrippers.com



Plan your next road trip route with Roadtrippers. Enter where you want to start and finish your road trip, and then discover the coolest "off the beaten path" places along the way.

Included in "Roadpass Pro".

Sanidumps

sanidumps.com

Sanidumps is a comprehensive RV dump station search site.



Togo RV

togorv.com



Features and benefits include RV-specific GPS navigation, high-value member discounts, access to free boondocking locations, service and maintenance schedule tracking, customizable checklists, RV Living stories, and a mobile repair locator.

Included in "Roadpass Pro".

ADDITIONAL INFORMATION

CAMPSITE LOCATORS

Go Camping America

gocampingamerica.com

Whether you're planning the cross-country trip of a lifetime or just a weekend getaway, GoCampingAmerica.com is the best way to find the perfect home away from home for your next adventure.



AllStays

allstays.com

AllStays has comprehensive lists, maps, apps, and search tools for over 37,000 campsites.



National Park Service - Find a Park

nps.gov/findapark

The National Park Service website is a great resource for information on the national parks across the country. From there you can find a park, research events, and discover trip ideas.



Campendium

campendium.com

Campendium lists tens of thousands of places to camp, vetted by their team, and reviewed by over 750,000+ members.

Included in "Roadpass Pro".



RV Life Campground Reviews

campgrounds.rvlife.com

RV Life Campground Reviews will help you find a campground with easy to use maps and visitor reviews.



USCampgrounds.info

uscampgrounds.info

Web listing of over 13,000 public campgrounds in the US and Canada that are vehicle-accessible, family campgrounds with 4 or more campsites.



NEWS & STORIES

Go RVing

gorving.com



The Go RVing program is the consumer-facing voice of the RV industry with a mission to inspire potential RVers, spark curiosity, and raise awareness about the benefits and accessibility of RVing through rich, authentic, and diverse storytelling.

OTHER INFORMATION

Neighbor

neighbor.com/rv-storage-near-me



Get out and use your RV more, store it with a neighbor. Find a spot on Neighbor.com—the world's largest RV storage & self-storage marketplace. Find space in your neighborhood today, it's closer, safer, and cheaper than traditional RV storage. Neighbor.com, like it never left home.

RVIA

rvia.org

RV Industry Association is the leading trade voice of the RV industry, representing approximately 495 manufacturers and component and aftermarket suppliers who together produce 98 percent of all RVs made in the United States, and approximately 60 percent of RVs produced worldwide.



Roadpass Pro

roadpass.com/pro



Purchasing a new Jayco Family RV makes you eligible for one FREE year of Roadpass Pro, which includes bonus features to the apps "Campendium", "Roadtrippers", and "FMCA".

Visit roadpass.com/first to sign up.

Current owners can receive a 30% discount on Roadpass Pro using the discount code below for your RV.

- Jayco Family: JAYCOFAMILY68

