



# CLASS C

OWNER'S MANUAL





Hello, I'm Ken Walters, President and CEO of Jayco. I'd like to personally welcome you to the Jayco Family.

The Jayco Family of Companies is comprised of four brands - Jayco, Entegra Coach, Open Range RV and Heartland RV. These divisions have been manufacturing RVs for over 50 years on a tradition anchored in three pillars - Quality, Team and Family. If you are a first-time owner, thank you for choosing us. If you're a second, third or tenth owner, we are beyond pleased to have kept you in the family.

Our mission has remained unchanged since 1968 - design and build with innovation and safety at the forefront of all we do, and continue to be a leading manufacturer for both towable and motorized RVs. From the first pop-up camper built on the Bontrager family farm, to the technology-packed lineup we build today, we always strive for better.

Over the next few years, we hope the memories made in your new RV are ones to remember. Thank you for taking us along for the ride and for letting us be a part of your stories.

Sincerely,

Ken Walters  
President and CEO of Jayco



## Training, How-To and Walk Through Videos

Scan the QR Code to access an extensive video training series for owners of Jayco & Highland Ridge brands of RVs, produced in collaboration with the National RV Training Academy (NRVTA). The series provides an in-depth library of videos to provide new and existing owners with training, reference and how-to material for nearly all of the systems and components you will utilize in your RV.



VIDEO  
LIBRARY



If you have passion for travel, love your RV and have an undeniably unique RV lifestyle, apply to become a Jayco Family of Companies' Pathfinder. As true pioneers and pathfinders of the authentic RV lifestyle, you are in the unique position to offer a genuine depiction of the different segments that come together to build an exclusive RV community. Through you, your stories and the compelling content you create, you'll elevate our brands while strengthening your own, increasing followers, inspiring RVers and establishing yourself as leaders and experts in the RV world.

## GET SOCIAL WITH US!



PATHFINDER  
COMMUNITY



FOLLOW  
US



CHANGE OF  
OWNERSHIP

## ABOUT THIS MANUAL

This manual is a guide to operation of the features, equipment and controls in your recreational vehicle (RV). If you find components vary significantly from what is described, please contact your dealer to ensure you have the correct information. Nothing in this manual creates any warranty, either expressed or implied, nor does it cover every possible detail of equipment, standard or option, installed on or in your RV.

Information, illustrations and specifications in this manual reflect the most current available at the time of publication approval, are subject to change and not intended to indicate actual size.

This Owner's Manual and Customer Information Packet are to be considered permanent components of the RV. Keep them in your RV at all times for personal reference. If the RV is sold, they should remain with the RV for the next owner.

## CUSTOMER INFORMATION PACKET

There are components that are excluded from the RV warranty, or are warranted separately by their own individual manufacturer's limited warranty. The Customer Information Packet contains the component manufacturer supplied manuals or information sheets, warranty cards and/or registrations. Consult this information for questions regarding operating, maintenance, servicing instructions and warranty coverage. It is important you complete and mail warranty cards and registrations within the prescribed time limits to avoid loss of warranty coverage.

### NOTICE TO QUEBEC RESIDENTS UNDER THE QUEBEC CONSUMER PROTECTION ACT – NO GUARANTEE OF AVAILABILITY OF REPLACEMENT PARTS AND REPAIR SERVICES

Most RVs are covered by a 2-year Limited Warranty. ***Please see our full warranty terms and conditions here, which also include a list of the RVs and their components covered by that Limited Warranty.***

Beyond the terms of the Limited Warranty, Jayco does not warrant or guarantee the availability of, and hereby explicitly disclaims any implied, statutory or other warranty or guarantee of availability of, any spare or replacement parts, repair services or information necessary for the maintenance or repair of RVs, their components or any other product offered for sale by Jayco.

**NOTICE TO CALIFORNIA CUSTOMERS ONLY:** Jayco, Inc. has elected to follow the procedures described in Cal. Civ. Proc. Code § 871.20 et seq., regarding pre-litigation notice requirements for consumer claims brought pursuant to the Song Beverly Consumer Warranty Act.

### WARNING: Read all instructions in this manual and component manufacturer supplied information before using your RV.

This manual has been provided by your recreational vehicle manufacturer for the sole purpose of providing instructions concerning the operation and maintenance of this recreational vehicle. Nothing in this manual creates any warranty, either expressed or implied.

**The owner's failure to provide required service and/or maintenance could result in the loss of warranty.** Please review the limited warranty and the limited warranties that apply to specific components offered with this vehicle.

Instructions are included in the manual for operating various components which are optional on some RV's or may not be available on your particular model. **"If equipped" does not indicate or imply that the component(s) or option(s) were at any time available, or can be retrofitted to your model.** In addition, the owner should refer to individual manufacturer's operating instructions contained in the customer information packet.

## CHASSIS GUIDE

Throughout this manual, frequent reference is made to the vehicle's Chassis Guide. The Chassis Guide includes the owner's manual provided by the manufacturer of the chassis on which this motor home is built, warranty cards and/or registrations. It also includes pertinent information regarding the transmission, tires, etc. Consult the Chassis Guide for operating safety, maintenance, servicing instructions and warranty coverage. The Chassis Guide should be considered a permanent component of the vehicle and kept in the motorhome at all times for reference.

## SAFETY ALERTS

Throughout this manual, certain items are labeled NOTE, NOTICE, CAUTION, WARNING, and DANGER. These signal words indicate precautions and potential situations, which if not avoided, may result in personal injury, property damage, or damage to your RV. These precautions are listed in the appropriate areas in this Owner's Manual, and in the information contained in the Warranty Packet, and on safety labels affixed to your RV. Read and follow them carefully.

National Safety Associations and organizations require many of the instructions listed. Always use the appropriate safety gear when servicing or maintaining your RV. Please call your dealer or our customer service representatives if you are unsure how to proceed.

## WARNINGS AND OTHER LABELS

Informational labels will be attached at various locations on the interior and exterior of your RV. These labels are there for your guidance and protection, and should never be tampered with or removed.

### NOTE

Gives helpful information.

### NOTICE

Indicates a potential situation that, if not avoided, may result in property damage or damage to your RV.



This is the safety alert symbol. It is used to alert you to potential personal injury hazards. Obey all safety messages that follow this symbol to avoid possible injury or death.

### CAUTION

Indicates a potentially hazardous situation that, if not avoided, may result in minor or moderate injury. It may also be used to alert against unsafe practices.

### WARNING

Indicates a potentially hazardous situation that, if not avoided, may result in death or serious injury.

### DANGER

Indicates an imminently hazardous situation that, if not avoided, will result in death or serious injury. This alert information is limited to the most extreme situations.





# TABLE OF CONTENTS

**INTRODUCTION**

**SECTION 2: OCCUPANT SAFETY**

**SECTION 3: PRE TRAVEL INFORMATION**

**SECTION 4: VEHICLE OPERATION**

**SECTION 5: SLIDEOUT SYSTEMS**

**SECTION 6: ELECTRICAL**

**SECTION 7: FUEL & PROPANE SYSTEM**

**SECTION 8: PLUMBING SYSTEM**

**SECTION 9: HEATING & COOLING**

**SECTION 10: APPLIANCES**

**SECTION 11: ELECTRONICS**

**SECTION 12: INTERIOR**

**SECTION 13: EXTERIOR**

**SECTION 14: CHECKLISTS**

**SECTION 15: ADDITIONAL INFORMATION**



# TABLE OF CONTENTS

## INTRODUCTION

ASCEND COMMUNITY .....	3
ABOUT THIS MANUAL .....	4
CUSTOMER INFORMATION PACKET .....	4
CHASSIS GUIDE .....	4
SAFETY ALERTS .....	4
WARNINGS AND OTHER LABELS .....	5

## SECTION 2: OCCUPANT SAFETY

FIRE SAFETY .....	10
FIRE EXTINGUISHER .....	10
SMOKE ALARM .....	10
SECONDARY MEANS OF ESCAPE (EXIT WINDOW) .....	11
COMBINATION CARBON MONOXIDE /PROPANE ALARM .....	11
FORMALDEHYDE .....	12
EXTENDED OR FULL TIME USAGE .....	12
CONDENSATION .....	12
COLD WEATHER USAGE .....	12

## SECTION 3: PRE TRAVEL INFORMATION

VEHICLE LABELS .....	14
WEIGHING YOUR MOTOR HOME .....	15
LOADING YOUR MOTOR HOME .....	15
TRAILER PLUG .....	16

## SECTION 4: VEHICLE OPERATION

VEHICLE OPERATION .....	17
TOWING BEHIND YOUR MOTOR HOME .....	17
ENTRANCE STEP .....	18
ENTRANCE DOOR .....	18
DRIVER AND PASSENGER SEAT .....	18
SEAT BELTS .....	18
CHILD SAFETY RESTRAINT SYSTEMS (IF EQUIPPED) .....	19
VEHICLE DASH .....	19
OUTSIDE REARVIEW MIRRORS .....	19
REAR VISION CAMERA .....	20
ELECTRIC REAR STABILIZER CONTROL (IF EQUIPPED) .....	20
BIGFOOT/QUADRA LEVELING SYSTEM (IF EQUIPPED) .....	20
LIPPERT LEVEL UP® MOTOR HOME LEVELING SYSTEM (IF SO EQUIPPED) .....	21
EMERGENCY STOPPING .....	23
EMERGENCY TOWING .....	24
FRONT AXLE TIRE ALIGNMENT .....	24
WHEEL LUG NUTS/WHEEL LINERS .....	24

CHANGING A TIRE .....	24
TIRES .....	25
AWNINGS .....	25
CAMPSITE HOOK-UP .....	26

## SECTION 5: SLIDEOUT SYSTEMS

ELECTRIC SLIDE ROOM(S) (IF EQUIPPED) .....	30
--	----

## SECTION 6: ELECTRICAL

THE ELECTRICAL SYSTEM .....	35
COMMAND CENTER .....	35
FIREFLY SYSTEM (IF EQUIPPED) .....	36
JAYCOMMAND PLUS BMPRO SYSTEM (IF EQUIPPED) .....	36
MAXX FAN REMOTE CONTROL (IF EQUIPPED) .....	37
MAXX FAN DELUXE (IF EQUIPPED) .....	38
TESTING THE CAMPSITE POWER CONNECTION .....	39
ENERGY MANAGEMENT SYSTEM 30A (IF EQUIPPED) .....	39
PROGRESSIVE DYNAMICS INVERTER (IF EQUIPPED) .....	40
POWER CONVERTER (IF EQUIPPED) .....	40
12-VOLT DC SYSTEM .....	41
BATTERIES .....	42
AUTOMATIC TRANSFER SWITCH (ATS) .....	43
LOAD CENTER .....	44
APPROXIMATE ELECTRICAL LOAD RATINGS .....	44
120-VOLT CIRCUIT BREAKERS .....	45
120-VOLT, 30-AMP AC ELECTRIC SYSTEM .....	45
GENERATOR .....	45
STARTING THE GENERATOR .....	46
SOLAR PREP (IF EQUIPPED) .....	46
SOLAR PANEL (IF EQUIPPED) .....	46

## SECTION 7: FUEL & PROPANE SYSTEM

EXHAUST GAS FUMES .....	49
FUEL SAFETY .....	49
PROPANE GAS SYSTEM (IF EQUIPPED) .....	49
PROPANE USE AND SAFETY (IF EQUIPPED) .....	51

## SECTION 8: PLUMBING SYSTEM

PLUMBING SYSTEM .....	54
MONITOR PANEL .....	54
FRESH WATER SYSTEM .....	55
DRAINING THE FRESH WATER SYSTEM .....	56
THE PLUMBING SYSTEM; SANITIZING AND WINTERIZING .....	56
WATER HEATER - TANK (IF EQUIPPED) .....	61
TRUMA® COMBI DIESEL 2 in 1 SYSTEM (IF EQUIPPED) .....	63

# TABLE OF CONTENTS

TRUMA® ON DEMAND WATER HEATER (IF EQUIPPED) .....	63	CLEANING THE DIAMOND SHIELD SURFACE .....	87
SUBURBAN ON-DEMAND WATER HEATER (IF EQUIPPED) .....	65	FRAME .....	87
WATER PURIFICATION SYSTEM .....	65	MUD FLAP .....	87
OUTSIDE SHOWER .....	66	EXTERIOR LADDER (IF EQUIPPED) .....	88
FAUCETS .....	66	EXTERIOR ROOF AND SIDEWALL VENTS .....	88
BATHROOM TUB / SHOWER.....	66	WINDOWS .....	88
SHOWER MISER .....	66	SEALANTS.....	88
BLACK/GREY WATER SYSTEM AND TANKS .....	67	<b>SECTION 14: CHECKLISTS</b>	
BLACK AND GREY TANK DRAINS .....	67	MOTOR HOME STORAGE .....	90
BLACK TANK FLUSH.....	68	TRAVEL CHECKLIST.....	91
TANK HEATERS (IF EQUIPPED) .....	69	<b>SECTION 15: ADDITIONAL INFORMATION</b>	
TOILET .....	69	HELPFUL LINKS .....	92
<b>SECTION 9: HEATING &amp; COOLING</b>			
AIR CONDITIONER .....	73		
FIREPLACE (IF SO EQUIPPED) .....	73		
FURNACE (IF EQUIPPED).....	74		
TRUMA® COMBI DIESEL 2 in 1 SYSTEM (IF EQUIPPED).....	74		
POWER ROOF VENT .....	74		
<b>SECTION 10: APPLIANCES</b>			
COOKING SAFETY.....	76		
COOKTOPS, RANGE AND OVEN (IF EQUIPPED).....	76		
INDUCTION COOKTOP (IF EQUIPPED).....	77		
MICROWAVE .....	77		
RANGE HOOD .....	77		
REFRIGERATOR .....	77		
LP GAS GRILL HOOKUP (IF EQUIPPED).....	78		
<b>SECTION 11: ELECTRONICS</b>			
WINEGARD CONNECT 2.0 (IF EQUIPPED).....	80		
EXTERIOR ENTERTAINMENT CENTER (IF EQUIPPED) .....	80		
<b>SECTION 12: INTERIOR</b>			
CLEANING THE INTERIOR.....	81		
SOFA AND DINETTE .....	82		
COUNTERTOPS .....	83		
PANTRY OR HUTCH (IF EQUIPPED) .....	83		
FLOORING.....	83		
CEILING FABRIC .....	83		
BED STORAGE.....	83		
PRIVACY DRAPE INSTALLATION.....	84		
BUNK BEDS AND BUNK LADDERS (IF EQUIPPED) .....	84		
<b>SECTION 13: EXTERIOR</b>			
CLEANING THE EXTERIOR.....	86		



# SECTION 2: OCCUPANT SAFETY



## FIRE SAFETY

If a fire does start, follow these basic safety rules:

1. Evacuate the vehicle immediately and call 911.
2. After everyone is accounted for, check the fire to see if you can attempt to put it out.
3. If it is large, or the fire is fuel-fed, get clear of the vehicle and have the Fire Department handle the emergency.
4. Do not attempt to use water to put out the fire. Water can spread some types of fire, and electrocution is possible with an electrical fire.

Refer to the following sections for additional fire safety information.

- Electrical Systems, In case of an electrical fire.
- Appliances, In case of a grease fire.

## FIRE EXTINGUISHER

**⚠ DANGER ⚠** **⚠ WARNING ⚠** (See page 13)

Fire extinguishers are classified and rated by fire type, A, B and C. These classifications identify the kinds of fires or burning materials they are designed to fight.

- **Class A** - Solid materials such as wood, paper, cloth, rubber and some plastics.
- **Class B** - Liquids such as grease, cooking oils, gasoline, kerosene or other flammable liquids.
- **Class C** - Electrical such as electrical wires or other live electrical equipment.

A dry chemical fire extinguisher has been installed by the entrance door. It is suitable for extinguishing small fires of the Class B or C type only.

We suggest you become thoroughly familiar with the operating instructions displayed on the side of the fire extinguisher.

## NOTE

For information on how to use your fire extinguisher, refer to the fire extinguisher user's manual included in your warranty packet.

## Inspection and maintenance

Read and follow all instructions on the label and user's manual provided by the fire extinguisher manufacturer.

## NOTE

Inspect the extinguisher at least once a week (more frequently if it is exposed to weather or possible tampering). This should also be done before beginning a vacation or during an extended trip.

## SMOKE ALARM

**⚠ WARNING ⚠** (See page 13)

Your recreation vehicle is equipped with a smoke alarm that is listed for use in recreation vehicles. The smoke alarm will only work if it is operational and maintained. **Refer to the manufacturer's user guide for detailed safety and operating information.**

Smoke Alarms have a limited life and will wear out over time. Immediately replace the detector if it is not working properly, if it displays any type of problem, or within five years of use.

Though the alarm horn in this detector meets or exceeds current UL standards, it may not be heard for reasons that include (but not limited to): a closed or partially closed door, other noise from electronics, appliances or traffic.

## SECONDARY MEANS OF ESCAPE (EXIT WINDOW)

**⚠ CAUTION ⚠** (See page 13)

Your recreation vehicle has been equipped with a window(s) that serves as a secondary means of escape. The window(s) will allow a quick exit from the vehicle during an emergency if access to the main entrance door is not available. It is easily identified by the red latches and label.



Exit Window Label

### Do not remove the EXIT window label from your RV.

When parking your recreation vehicle, make sure the egress window is not blocked by trees or other obstacles. Make sure the ground below the window is solid and can be used as an escape path.

Practice opening the window before an emergency occurs, and make sure all occupants know how to operate it.

## NOTE

All windows must be closed and locked while the RV is in transit.

Your recreation vehicle may be equipped with one of the following exit window styles:

### Flip latch style (2 per window)

1. Push up on the front lip of the latch and the latch unfolds.
2. Push up on the front lip of the latch again to unhook the latch from the window.
3. When both latches are released, push out on the window which is hinged at the top. Exit the vehicle.



The screen does not need to be removed from the window.

### Slider window latch style

1. Pull the lever down to unlock the window.
2. Slide the window to the right to open and exit the vehicle. The screen does not need to be removed from the window.

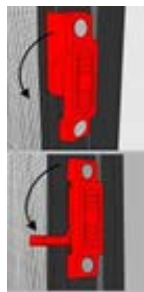

### Lever style latch

1. Remove the screen by pulling the red tab (upper right arrow).
2. Pull the lever out from the sash clamps.
3. Swing the lever out so it is positioned straight out from the window.
4. Push the lever (and window) out to open and exit the vehicle.

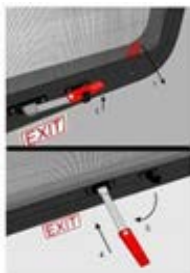

## COMBINATION CARBON MONOXIDE /PROPANE ALARM

**⚠ WARNING ⚠** (See page 13)

Your recreation vehicle is equipped with a combination carbon monoxide (CO) / propane alarm that is listed for use in recreation vehicles. The combination carbon monoxide/propane alarm will only work if it is operational and maintained. **Refer to the manufacturer's user guide for detailed safety and operating information.**

The alarm is directly wired to the 12-volt electrical system, with continuous power being supplied by the recreational vehicle batteries. There is no 9-volt battery power supply. As a result, the alarm is always drawing a small amount of current from the recreation vehicle batteries. Although the current draw is slight, it could drain the batteries during extended storage periods. This condition is not likely to occur except during storage situations when the inverter cannot restore the battery charge. **If the battery cable is disconnected at the battery terminals, the combination alarm will not work.**



Carbon monoxide/propane alarm (alarm may vary from model shown)

Carbon monoxide (CO) is an insidious poison. It is a colorless, odorless and tasteless gas. Many cases of reported carbon monoxide poisoning indicate while victims are aware they are not well, they become so disoriented they are unable to save themselves by either exiting the recreational vehicle or calling for assistance. Young children and household pets may be the first affected.

Your combination carbon monoxide/propane alarm is designed to detect the toxic carbon monoxide fumes that result from incomplete combustion, such as those emitted from appliances, furnaces, fireplaces and auto exhaust.

This alarm is designed to sense the presence of carbon monoxide/propane gas, however there are other combustible fumes or vapors that may be detected by the sensor including (but not limited to): acetone, alcohol, butane and gasoline.

These chemicals can be found in commonly used items such as deodorants, colognes, perfumes, adhesives, lacquer, kerosene, glues, wine, liquor, most cleaning agents and the propellants of aerosol cans.

High temperatures can activate glue and adhesive vapors. If you close up a recreational vehicle on a hot day, the chemicals used in its construction may be detected for months after the vehicle was constructed (for more information, refer to Sec. 2, Formaldehyde).

1. If the CO alarm sounds with a 4-chirp pattern:
2. Immediately move to fresh air—outdoors or by an open door or window. Do a head count to check that all persons are accounted for. Do not re-enter the premises, or move away from the open door or window until the emergency services responder has arrived, the premises have been aired out, and your CO Alarm remains in its normal condition.
3. Call your emergency services, fire department or 911.
4. After following steps 1-2, if the CO Alarm reactivates within a 24-hour period, repeat steps 1-2 and call a qualified appliance technician to investigate for sources of CO from fuel-burning equipment and appliances, and inspect for proper operation of this equipment. If problems are identified during this inspection have the equipment serviced immediately. Note any combustion equipment not inspected by the technician, and consult the manufacturers' instructions, or contact the manufacturers directly, for more information about CO safety and this equipment. Make sure that motor vehicles are not, and have not, been operating in an attached garage or adjacent to the residence.

## OCCUPANT SAFETY

If the Propane alarm sounds with constant beeps:

1. Immediately evacuate the from the RV.
2. Shut off propane gas supply at propane tanks or supply.
3. Do not touch any electrical switch in or near the RV
4. Do not start vehicle's engine.
5. Contact a qualified RV or gas technician for repairs.
6. Do not turn on gas supply unit the leak has been repaired.

### FORMALDEHYDE

Some components in the recreation vehicle contain formaldehyde-based adhesives that may release formaldehyde fumes into the air for an unknown period of time. Individuals who are allergic to formaldehyde gas fumes may experience irritation to eyes, ears, nose and throat. Indoor air quality may also be affected by leaving your vehicle closed for a period of time.

To aid in dissipation, ventilate the recreation vehicle by opening all windows and circulate the air with a fan.

This label is located inside the vehicle near the entry door. **The label should be left permanently affixed to the recreation vehicle.**



### EXTENDED OR FULL TIME USAGE

Your new recreation vehicle has been built for enjoyment in a recreational manner. It is not intended for use as full-time quarters or a permanent residence. Continuous living in your vehicle could cause accelerated wear and damage to the various components.

### CONDENSATION

 **WARNING**  (See page 13)

Condensation is a natural phenomenon. The amount of condensation will vary with climate conditions, particularly the relative humidity. Condensation occurs because there is water vapor present in the air. When the temperature reaches the "dew point" the water vapor in the air condenses and changes to a liquid form.

Proper ventilation or the use of a dehumidifier (customer supplied) will assist in controlling the condensation. Suggestions to eliminate warm moist air:

- Crack open windows and roof vents to allow warm moist air to escape.
- Open the bath roof vent (if so equipped) approximately 1/2" when showering.
- Use the range hood fan (if so equipped) when cooking or washing dishes.
- Avoid hanging wet towels (or clothes) inside the recreation vehicle to dry.
- If found in cabinets or closets, open the doors slightly to provide ventilation.

### COLD WEATHER USAGE

When used in freezing or below freezing temperatures, the precautions should be taken:

- Fresh water and drainage systems - preparations to avoid freeze-ups.
- Propane gas (if so equipped) and sufficient power is needed for protection from possible freeze-ups on the propane gas regulator. Keep in mind that more frequent furnace operation will substantially increase battery draw and propane gas use.
- During cool weather usage, ventilation or addition of a dehumidifier may be required to reduce condensation.
- Check outside extrusions on compartment doors, locks, slide outs, windows, vents, etc., for frozen moisture before operating to avoid damage to parts.



**OCCUPANT SAFETY DANGER**

### FIRE EXTINGUISHER ((See page 10)

Do not turn the electrical power back on or plug in any appliances after the use of a fire extinguisher. Please refer to the fire extinguisher's user manual for further instructions on maintenance and clean up.



### **COMBO CO2/PROPANE ALARM (See page 11)**

- Do not cover or obstruct the carbon monoxide/propane alarm with anything that could prevent gas from entering the alarm.
- This alarm is not designed to detect smoke, fire or gases other than carbon monoxide and propane.
- The carbon monoxide detector installed is intended for use in ordinary indoor locations of recreation vehicles. It is not designed to comply with Occupational Safety and Health Administration (OSHA) commercial or industrial standards.
- Do not disconnect the battery or the alarm.
- Individuals with medical problems may consider using warning devices that provide audible and visual signals for carbon monoxide concentrations under 30 PPM.
- This alarm will only indicate the presence of carbon monoxide gas at the sensor. Carbon monoxide gas may be present in other areas.
- The ultimate responsibility for protection against toxic carbon monoxide fumes rests solely on you. Installing a carbon monoxide/propane alarm is just the first step in protecting your family from toxic carbon monoxide poisoning. The following symptoms are related to carbon monoxide poisoning and should be discussed with all members of the household:
  - Mild exposure: Slight headache, nausea, vomiting, fatigue (often described as “flu-like” symptoms).
  - Medium exposure: Severe throbbing headaches, drowsiness, confusion, fast heart rate
  - Extreme exposure: Unconsciousness, convulsions, cardio-respiratory failure, death
- Actuation of this detector indicates the presence of carbon monoxide which can kill you.
- Never turn the 12-volt battery disconnect control to the off position and disconnect the battery cable to silence an alarm. The alarm will automatically sense when the level of carbon monoxide in the air reaches below dangerous levels. You should stay outside the vehicle in fresh air until the alarm is silenced. When the alarm sounds, do not stand too close to the alarm. The sound produced by the alarm is loud (85db) because it is designed to wake a person in an emergency. Prolonged exposure to the alarm at a close distance may be harmful to your hearing.

### **CONDENSATION (See page 12)**

Condensation may cause dampness, mildew, mold, staining and, if allowed to continue, it may result in damage to the recreation vehicle (damage caused by condensation is not warrantable). It can also lead to mold or mildew issues, which could be a health hazard.

### **SMOKE ALARM (See page 10)**

- **This smoke alarm will not alert hearing impaired residents.** Special alarms with flashing strobe lights are recommended for the hearing impaired
- Smoke Alarms cannot work without power. Battery operated units cannot work if the batteries are missing, disconnected or dead, if the wrong type of batteries are used, or if the batteries are not installed correctly.
- Only use the replacement battery recommended by the smoke detector manufacturer. The smoke detector alarm may not operate properly with other batteries. Never use a rechargeable battery as it may not provide a constant charge. Never disconnect the battery to silence the alarm.
- Smoke Alarms cannot detect fires if the smoke does not reach the Alarms. Anything preventing smoke from reaching the alarm may delay or prevent an alarm.
- Test the smoke alarm operation after the vehicle has been in storage, before each trip and at least once per week during use. Do not disconnect the battery or the alarm.
- Smoke Alarms are not foolproof and cannot prevent or extinguish fires.

### **FIRE EXTINGUISHER (See page 10)**

Do not check the pressure, test or practice using the fire extinguisher by squeezing the trigger, even briefly. The fire extinguisher is not rechargeable or refillable. Once used, it will gradually lose pressure and will not be fully charged for use in an emergency.



### **SECONDARY MEANS OF ESCAPE (See page 11)**

Exercise care when opening the exit window. If opened too far, it may come off the hinge. This may result in damage to the unit or window.

### **EXTENDED/FULL TIME USAGE (See page 12)**

Continuous or permanent living in your recreation vehicle may affect your warranty coverage and may void the “Limited Warranty” applicable to your vehicle.

# SECTION 3: PRE TRAVEL INFORMATION



## VEHICLE LABELS

**⚠ WARNING ⚠** (See page 16)

Decals and data plates used throughout the motor home aid in its safe and efficient operation; others give service instructions. Read all decals, data and instruction plates before operating your recreation vehicle. Any decal, data or instruction plate painted over, damaged or removed should be replaced.

Keep a record of the 17-digit chassis vehicle identification number (VIN), the 8-digit serial number, and your license number in the event theft or vandalism requires you to supply this information to the authorities.

### Weight Terms

**GAWR - Gross Axle Weight Rating:** The value specified by the vehicle manufacturer as the load-carrying capacity of a single axle system, as measured at the tire-to-ground interfaces. This is the total weight a given axle is capable of carrying.

**GCWR - Gross Combined Weight Rating:** The value specified by the motor home manufacturer as the maximum allowable loaded weight of the motor home in combination with its towed trailer or towed vehicle. The tongue weight of a towed vehicle/ trailer counts as part of the motor home cargo.

**GVWR - Gross Vehicle Weight Rating:** The value specified by the manufacturer as the maximum permissible weight of the fully loaded motor home.

**OCCC - Occupant and Cargo Carrying Capacity:** Is equal to the GVWR of the motor home minus the:

- weight of the motor home, as completed at the factory
- weight of all occupants, including the driver
- weight of all personal cargo
- weight of a full tank of chassis engine fuel
- weight of a full tank of propane (if applicable)

The full weight of potable water, including the water heater and the tongue weight of a towed vehicle/ trailer counts as cargo in or on the motor home. Additions to or other changes made to the motor home after it left the factory will affect (reduce) the OCCC.

**UVW - Unloaded Vehicle Weight:** The weight of this motor home as manufactured at the factory with fuel, engine oil and coolants and if applicable, the weight of a full tank of propane.

### Weight and Capacity Labels

The following labels are located on the inward-facing surface of the main entry door of the motor home and on the lower sidewall left of the driver's seat.

**OCCC Label (Occupant and Cargo Carrying Capacity):** The upper portion of this yellow label is federally required and indicates the total combined weight value of occupants and cargo that may be placed in or on your motor home as it was manufactured and weighed before leaving the factory.

# PRE TRAVEL INFORMATION

This label also indicates the number of safety seat belts that have been installed at the factory. Additions or other changes made to the motor home after it left the factory will affect (reduce) the OCCC.

The lower portion of the label is provided voluntarily and indicates the weight value of the motor home as it was manufactured and weighed before leaving the factory. This label also indicates the GCWR of the completed motor home.

**The motor home towing and braking label** is located on the rear bumper above the hitch receiver. Be sure to read and follow the guidelines and information stated on this label. Refer to the Chassis Guide for additional information.

**For more information:** Consult a hitch specialist or your dealer for assistance when preparing your motor home for towing a vehicle or trailer.

MFG. BY: INC. VEHICLE MFG. BY/	<b>XXXXXX</b> XXXXXXXXXXXX	Date: XX/XX
V.I.N./N.I.V XXXXXXXXXXXXXXXXXXXX		
GVWR KG/LBS. XXXX / XXXX	SIZE/DIMENSION	
GAWR KG/LBS. XXXX / XXXX	TIRE	RIMS
	FRONT	XXX X XXX
	INT	XXX X XXX
	REAR	XXX X XXX
		COLD INFL. KPA / PSI
		XXX / XXX
		SINGLE
		DUAL
TYPE OF VEHICLE: MPV, MOTORHOME		
THIS VEHICLE CONFORMS TO ALL APPLICABLE U.S. FEDERAL MOTOR VEHICLE SAFETY STANDARDS IN EFFECT ON THE DATE OF MANUFACTURE SHOWN ABOVE.		

Federal Certification Label

## WEIGHING YOUR MOTOR HOME

**⚠ WARNING ⚠** **⚠ CAUTION ⚠** (See page 16)

When your motor home is loaded you should have it weighed. The actual weight of the motor home, passengers, all options, liquids, the hitch weight of your towed vehicle and your personal cargo is important for you to know so you do not exceed the GVWR. There are two important factors when loading your motor home, total weight and balance.

It is imperative that you verify compliance within all applicable weight ratings. Overloading your motor home will void the **Limited Warranty** and the warranties of many component part manufacturers.

**Periodically weigh your motor home at a public scale to determine proper load distribution.** To obtain the side-to-side weights, there needs to be enough space on either side of the scale to accommodate the motor home being partially off the scale.

Different types or scales may require different procedures when weighting the motor home. The motor home must remain as level as possible on the scale (even if an axle is not physically on the scale). To obtain the side-to-side weights, make sure there is enough space on either side of the scale to accommodate the motor home being partially off the scale.

If a boat, trailer or other vehicle is being towed, it should be weighed separately. Combine this weight with the motor home's Gross Vehicle Weight (GVW) to ensure the total combined weight does not exceed the GCWR.

Once actual weights are obtained, compare them to the **Weight Information Label** weight ratings to ensure you are below the posted minimum ratings.

If there is a difference in the weights on one side of the vehicle as compared to weights on the other side, components (tires, wheels, brakes, springs, etc.) on the heavier side may be overloaded, although the total axle load is within the GAWR.

## LOADING YOUR MOTOR HOME

**⚠ WARNING ⚠** (See page 16)

When loading heavy objects keep them as low as possible, preferably on the floor. Store and secure all loose items inside the motor home before traveling. Overlooked items can become dangerous projectiles during a sudden stop.

**MOTOR HOME OCCUPANT AND CARGO CARRYING CAPACITY**  
VIN: XXXXXXXXXXXXXXXX ( XXXXXXXX )  
**THE COMBINED WEIGHT OF OCCUPANTS AND CARGO SHOULD NEVER EXCEED:**  
XXXX kg. OR ( XXXX Lbs )  
**SAFETY BELT EQUIPPED SEATING CAPACITY: X**  
**CAUTION:**  
**A FULL LOAD OF WATER EQUALS XXX kg. or ( XXX Lbs ) OF CARGO @ 1 kg/L (8.3Lb/gal) AND THE TONGUE WEIGHT OF A TOWED TRAILER COUNTS AS CARGO**

Upper Section Federal OCCC Weight Labels

**THE WEIGHT OF THIS RECREATION VEHICLE MOTOR HOME AS COMPLETED AT THE FACTORY WITH FULL PROPANE CYLINDER(S) AND FULL GENERATOR FUEL IF APPLICABLE IS: XXXX kg. OR ( XXXX Lbs.)**  
**THE GCWR OF THIS RECREATION VEHICLE MOTOR HOME IS XXXX kg. OR ( XXXX Lbs.) CONSULT YOUR DEALER AND SEE OWNER'S MANUAL FOR DEFINITIONS, ADDITIONAL WEIGHT LOADING, WEIGHING INFORMATION AND TOWING GUIDELINES INCLUDING AUXILIARY BRAKE REQUIREMENTS FOR ANY TOWED TRAILER OR VEHICLE**  
**RECREATIONAL VEHICLE OVERALL LENGTH XXX M ( XX FT. X IN.) EXCLUDING RV APPURTENANCES AS DEFINED BY THE RV MANUFACTURER.**

Lower Section Federal OCCC Weight Labels

**The Federal Certification Label** is required by the government to verify the RV complies with all motor vehicle standards for Canada and the United States. It includes the following information: Manufacturer name, VIN, GVWR, GAWR (front/rear), tire and rim sizes and cold tire inflation pressures.

## ⚠ WARNING

The braking capacity of your motor home is not necessarily as great as its towing capacity. Separate braking systems should be used for control of a towed vehicle, (auto, trailer, boat etc.), behind the motor home. Braking requirements will vary by chassis type, chassis manufacturer and state law. Contact your chassis dealer or independent RV dealer for assistance to determine if a separate braking system is recommended and what limit(s) may apply for your towing combination and traveling safety.

The use of a reducing sleeve and smaller diameter draw bar or a longer draw bar in and on the hitch receiver will reduce the hitch weight rating and towing capacity. Use of a draw bar longer than 18-inches (457mm) is prohibited.

Consult your vehicle owner's manual(s) and your independent RV dealer for specific weighing instructions and towing guidelines.

Improper use of towing equipment and towing setups can cause loss of control that may lead to an accident resulting in death or serious injury.

Motor Home Towing and Braking Label

## PRE TRAVEL INFORMATION

Distribute cargo side-to-side so the weight on each tire does not exceed one-half of the GAWR for either axle. Make sure any tie down straps (if so equipped) on appliances or furniture are secure. Load heavy objects on the floor, or as low as possible.

### TRAILER PLUG

If you choose to tow behind your RV, a trailer plug (located at the hitch) is pre-wired into your motor home. Before hitching up to a trailer, please read Using the Rear Hitch, vehicle weight ratings, etc. Your motor home will have a 7-way trailer receptacle (combination 4-way / 7-way on some models). Wiring to operate your towed vehicle brakes must be the same size in both the towed vehicle and the motor home.

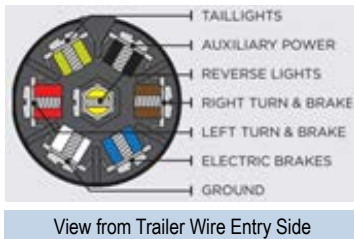

The connector plug may build up corrosion with extended use. It should be cleaned periodically to insure good electrical contact. Make sure the connector plug is kept clean and protected from road elements as you travel.

### NOTE

A 12V circuit tester is recommended to verify trailer connections.

Refer to the manufacturer owner's manual for detailed operating instructions.



### PRE TRAVEL INFORMATION WARNING

#### **WEIGHING YOUR MOTOR HOME (See page 15)**

Dump the gray and black water holding tanks before traveling to avoid carrying unnecessary weight. Full tanks can affect your fuel consumption, and depending on tank location, can affect your vehicle handling characteristics. If you cannot immediately empty your holding tanks, reduce your vehicle speed until you reach a dumping station.

#### **VEHICLE LABELS (See page 14)**

The factory-installed weight labels are specific to the recreation vehicle for which they are supplied and are not interchangeable. Do not remove these labels from your vehicle. If labels are missing contact your dealer or Customer Service for replacements.

- Do not exceed any applicable motor home weight ratings. Doing so could damage your motor home or affect handling and braking characteristics.
- Your motor home braking system is designed and rated for operation at GVWR not GCWR.

#### **LOADING YOUR MOTOR HOME (See page 15)**

- Never load the motor home in excess of the GVWR or the GAWR for either axle. Overloading your motor home may result in adverse handling characteristics and damage to the chassis.
- **DO NOT EXCEED YOUR GVWR!** This means you should weigh your vehicle as loaded for your normal travel to determine the actual weight. If you exceed the GVWR, you **MUST** remove items from the motor home, or drain liquids, then re-weigh the vehicle to ensure you have achieved a safe weight.
- The actual weight of the vehicle, passengers, all options, liquids, the hitch weight of your towed vehicle and your personal cargo is important for you to know so you do not exceed the Gross Vehicle Weight Rating (GVWR) of the motor home. The volume of space available for storage may exceed the amount of available cargo capacity. Large storage compartments have been designed to accommodate normal camping items, which are bulky, but not necessarily heavy.
- Your recreation vehicle's load capacity is designated by weight, not by volume, so you cannot necessarily use all available space when loading the vehicle. Do not exceed your GVWR and ensure you are loading the vehicle as evenly as you can for the best possible handling. Ensure heavy items are secured so they do not shift during travel.
- Store items in areas designated for storage. Do not store anything in the areas reserved for the converter, electrical panels, furnace or water heater, etc.
- For traveling safety, it is important to make sure the tie down straps are secured on all appliances such as the toaster, coffee maker, etc. Vibration during travel will move the appliances, creating the potential for them to fall out of their cabinets possibly causing injury.



### PRE TRAVEL INFORMATION CAUTION

#### **WEIGHING YOUR MOTOR HOME (See page 15)**

It is important to redistribute the load to avoid component failure as well as to improve the handling characteristics of the vehicle.

# SECTION 4: VEHICLE OPERATION



## VEHICLE OPERATION

**⚠ WARNING ⚠** (See page 27)

Your motor home will travel safely and comfortably at highway speed limits. However, it will take longer than a passenger automobile to reach that speed. Allow more time to go around the vehicle you are passing. Avoid situations that might require sudden momentum changes as the length of the motor home affects your ability to quickly cut back into traffic. Swerves and sharp turns, especially at high speeds, could result in loss of control of the motor home.

The motor home has a longer turning radius. When turning, check the road clearance and be aware of others, especially if towing a vehicle behind your motor home.

Adverse weather conditions and extremes in terrain may affect the performance and handling of your vehicle. **Do not** operate the cruise control on icy or extremely wet roads, gravel roads, winding roads, in heavy traffic, or in any other traffic situation where a constant speed cannot be maintained. Use care when accelerating or decelerating on a slippery surface. Abrupt speed changes can cause skidding and loss of control.

## NOTE

**CALIFORNIA TIRE CHAIN NOTICE:** YOUR MOTOR HOME MAY NOT BE OPERATED WITH TIRE CHAINS.

### Braking and Stopping

Even though your motor home is equipped with brakes designed for its Gross Vehicle Weight Rating (GVWR) we suggest you practice stopping away from traffic until you become accustomed to your motor

home's stopping distance. Your motor home is equipped with a third brake light that activates when the brakes are engaged.

When descending a long hill, shift the transmission into a lower gear and engage the auxiliary engine braking. If your motor home is equipped with an auxiliary engine brake, engagement is activated by a switch on the driver's console. See the chassis owner's manual for additional information. The transmission and engine will help in controlling downhill speed and can lengthen brake life. The distance required to stop the motor home is greater than an automobile's.

Driving through water deep enough to wet the brakes may affect stopping distance or cause the vehicle to pull to one side. Check the motor home's brake operation in a safe area to be sure they have not been affected. **Never operate any vehicle if a difference in braking efficiency is noticeable.**

### Parking Brake

The parking brake should be engaged when the motor home is parked. Never drive your motor home with the parking brake engaged as this will reduce braking effectiveness and cause excessive driveline wear. Refer to your Chassis guide for more information on the parking brake.

## TOWING BEHIND YOUR MOTOR HOME

**⚠ WARNING ⚠** **⚠ CAUTION ⚠** (See page 27) & (See page 29)

Towing will affect vehicle handling, durability and fuel economy. Exceeding any of the listed weight ratings will result in unacceptable overall vehicle performance. Your safety and satisfaction require proper use of correct equipment.

# VEHICLE OPERATION

For maximum pulling load and vertical tongue weight, refer to the label located on the rear hitch. A hitch bar of appropriate strength and steel should be selected to meet the capacities of the towing receptor.

Always use safety chains between the motor home and the towed trailer or vehicle. Cross the chains under the tongue and allow for slack when turning corners. Connect the safety chains to the vehicle frame or hook retainers. Never attach the safety chains to the bumper.

Before descending a steep or long grade when towing a trailer or vehicle, reduce speed and shift the motor home into a lower gear to control vehicle speed. Avoid frequent or prolonged brake application, which can cause overheating or brake failure.

By definition the GCWR is “the maximum total weight rating allowed for a vehicle and any attachment, such as a trailer or towed vehicle. To determine the total allowable weight for a towed item, subtract the GVWR from the GCWR.

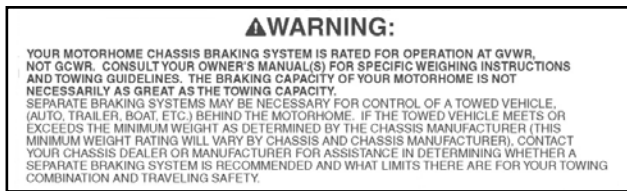

Towing and Braking Label

In addition, a separate supplemental braking system must be installed if the towed trailer or vehicle meets or exceeds the minimum weight determined by the chassis manufacturer (*this minimum weight rating will vary by chassis and chassis manufacturer*).

Contact your dealer for assistance in determining whether a separate braking system is recommended for your towing and traveling safety. Failure to follow these instructions will create a safety hazard and may result in an accident.

## Maintenance

Keep the hitch clean along with your general frame maintenance.

- At the beginning of the season, and monthly or thereafter, clean the inside of the receiver tube with a wire brush and spray with a silicone spray.
- Always remove the utility mount from the receiver when it is not in use. This will help prevent the utility mount from rusting to the tube.
- Periodically check the bolts for tightness. They need to be torqued to the proper setting (refer to your Chassis Guide).

Refer to the chassis manual for detail on hitch specifications and towing guidelines.

## ENTRANCE STEP

**⚠WARNING ⚠** (See page 28)

The electric door step opens automatically when the screen door is opened. Constant 12-volt power to the electric step is supplied through a circuit breaker.

## ENTRANCE DOOR

**⚠CAUTION ⚠** (See page 29)

Always hold onto the entrance door when opening or closing it. Damage caused because you failed to do so is not covered by the **Limited Warranty**.

The entrance screen door may be equipped with a slide panel that allows access to the entrance door handle and locks. The entrance door may also be equipped with both a regular door lock and a dead bolt lock.

## Keys

Several keys are provided when you purchase your vehicle. Most keys have an individual key number stamped on the plate. Record these key numbers and keep the information in a safe place. You can order a key blank from your dealer to have duplicate keys made. If you lose the keys, contact your dealer or a locksmith for assistance.

## Maintenance

Locks on entrance and baggage doors need biannual lubrication using a light coat of silicone spray. Conditions such as rain, salt, dust and pollution may increase the maintenance needs.

## DRIVER AND PASSENGER SEAT

**⚠WARNING ⚠** (See page 29)

## NOTE

The driver's and front passenger seat must be locked in the forward facing position while the motor home is in motion.

## Power Seat (if so equipped)

Use the controls to slide the power seat to the desired position. Depending on your model, seat controls may be located on the seat or on the door. Release the control, and the seat will lock at that position. Features may include a 3-point adjustable seat belt, lumbar support, swivel, slide and reclining capabilities. (Not all of these features will be available in all motor home models).

## To rotate the driver/passenger seat

Depending on your model, you may have the ability to rotate the driver/passenger seats towards the rear of the motor home. To face the driver or front passenger seat toward the rear of the vehicle, pull the seat swivel release lever up and rotate the seat. To return the seat to the original position, rotate seat back to the driving position until you hear a click and the seat locks into position.

## SEAT BELTS

**⚠WARNING ⚠** (See page 28)

Always use seat belts. In an accident, injury to the driver and passengers may be reduced if seat belts are properly used. If your motor home is equipped with a booth dinette, hide-a-bed sofa, or easy bed sofa they will have two-point lap-seat belts installed. **Seat belts should be used in all seating positions.**

## Maintenance and inspection of seat belts

The webbing used in seat belts may be cleaned with a mild soap or detergent solution. Allow the belts to dry in the shade and do not allow them to retract until fully dry.

## VEHICLE OPERATION

Regularly check the seat belt buckles and release mechanisms for positive action and check automatic locking retractors for positive engagement.

If the seat belt webbing shows obvious cuts, protruding broken fibers or severe fading which indicates weakening by exposure to sunlight, the entire seat belt assembly should be replaced. Do not try to bleach or re-dye the belts. The resulting color may rub off and the webbing strength could be affected.

### CHILD SAFETY RESTRAINT SYSTEMS (IF EQUIPPED)

**⚠ DANGER ⚠** **⚠ WARNING ⚠** (See page 26)

When transporting infants or small children, an appropriate child safety restraint system should always be used.

### NOTE

- All child safety restraint systems should always face the front or rear of the motor home. They should never be installed so the occupant is facing the side of the motor home.
- Children too large for a child safety seat (per government specifications) should always wear a seat belt.

### Booth Dinette (if equipped)

**⚠ WARNING ⚠** (See page 27)

If your child requires a child safety restraint system (seat), it can be installed in the forward or rear facing booth dinette according to the instructions of the safety seat manufacturer. The seat must be secured with the dinette seat tether strap.



Table Warning Label

### VEHICLE DASH

**⚠ WARNING ⚠** (See page 29)

#### Maintenance:

To clean the vinyl/ABS dash, soak a soft cloth in a solution of mild detergent and water. Wipe off the dash. To rinse, dip a cloth in fresh water and wring it out well. Wipe off the detergent thoroughly.

### Installing the Child Safety Seat

### NOTE

Be sure to read, understand and apply all child seat information provided by the seat manufacturer. Make sure the tether strap is securely and correctly attached to the child safety seat.

Locate the child seat tether anchors (brackets). The anchors will be marked with a child seat symbol. Attach the snap on the strap of the child restraint seat to the corresponding anchor. Adjust the strap so the seat is securely in place. The seat must have both lower straps securely in place. Repeat the process on the upper straps of the child seat.



Child Seat Anchor Symbol



### OUTSIDE REARVIEW MIRRORS

**⚠ CAUTION ⚠** (See page 29)

After adjusting the front driver's seat, adjust the outside rearview mirrors to your driving preference. Have someone help you adjust the mirrors in the desired direction for maximum rear visibility before driving. During travel, vibration may loosen the fitting holding the mirror(s), causing them to change position. As part of your regular motor home maintenance, check and adjust the mirrors to the desired position.

#### Power Remote Mirrors (if so equipped)

You can adjust the power remote mirrors when the ignition key is in the ON position.

1. Move the control knob to the side you want to adjust.
2. Press the control arrows in the direction you want the mirror to move.
3. Return the control knob to the center to lock the mirror(s) into place.



Remote Mirror Control/Mirror Heat Control (appearance may vary by model)

The power remote mirrors also contain heating elements to defog or de-ice the mirrored glass if needed. To activate this feature, use the "Mirror Heat" control located on the driver's side console next to the mirror control joystick.

### NOTE

Depending on models, the mirror control joystick and the Mirror Defrost toggle switch may be separated from each other. The Mirror Defrost switch may be renamed Mirror Heat.

# VEHICLE OPERATION

## REAR VISION CAMERA

**⚠ WARNING ⚠** (See page 27)

The rear vision monitor gives a limited televised view of what is behind your motor home. The rear vision camera will aid you in backing up the motor home, and can be used for a greater field of vision when driving in heavy traffic.

The monitor is operational whenever the engine is running. To use the monitor, flip the switch from standby to ON (the monitor will also work when with the motor home is in “reverse” and the monitor in standby). **Make sure you turn the monitor to standby while driving to avoid being distracted.**

Your RV may also be equipped with side view cameras mounted in the mirrors or on the body of the motor home (facing rearward) to give you views down each side of the motor home. Check the outside rear view mirrors when driving and backing for a more complete field of vision.

For detailed operating and safety information, refer to the manufacturers user guide.

## ELECTRIC REAR STABILIZER CONTROL (IF EQUIPPED)

**⚠ CAUTION ⚠** (See page 29)

The (2) electrically operated stabilizers are located at the rear of the coach, and when extended, will keep the motor home from rocking side to side. The control has a power switch and a switch to extend/retract the stabilizers, and is typically located inside the coach stepwell.

To use the system, press the power switch to the “ON”. To extend the stabilizers, press and hold the extend/retract switch in the extend position until the stabilizers are fully extended. When fully extended, the LED light at the bottom of the panel marked “EXTENDED” will light up. To retract the stabilizers, press and hold the extend/retract switch in the retract position. The LED light will go off and the stabilizers will retract. Turn the power switch OFF.

If the jacks are down and the vehicle is started and put in gear, an alarm will sound to let you know the jacks must be retracted.



## BIGFOOT/QUADRA LEVELING SYSTEM (IF EQUIPPED)

**⚠ WARNING ⚠** **⚠ CAUTION ⚠** (See page 28) & (See page 29)

Your recreation vehicle may be equipped with a 4-point automatic leveling system. This control panel is typically located in the stepwell of the motor home or at the Command Center Panel inside the RV.

The following is an overview of the system and to be used as a quick reference. **For detailed operating and safety instructions, refer to the manufacturer owner’s manual.** Familiarize yourself with the operating and safety instructions prior to using the leveling system. Depending on your model, the system may vary slightly from the following instructions.



Prior to operation, make sure the following conditions are met:

- The recreation vehicle is parked on a reasonably level surface.
- Transmission should be in PARK.
- Apply the parking brake.
- **REMOVE IGNITION KEY FROM VEHICLE IGNITION! (System will not operate with the ignition ON).**
- Be sure the batteries have been fully charged.

## NOTE

- When the unit is level, the green foot in the center will flash on and off.
- If jacks are extended and vehicle is put in gear and the parking brake released, the jacks will automatically retract.
- Turn off all lights and other electrical elements during operation.
- Minimize movement inside the coach when in auto leveling mode.
- Be sure all persons, pets, and property are clear of the motor home while the system is in operation.

## Leveling Control Panel Callouts

**POWER:** Turns the leveling system ON/OFF.

**MANUAL:** Allows you to manually level the RV.

**AUTO LEVEL:** Places the system in AUTO LEVEL mode.

**RETRACT:** Allows the user to retract all jacks.

- When in MANUAL mode, press the RETRACT button and hold it until desired levelers are retracted.
- When in AUTO mode, simply push the RETRACT button one time.

**EMERGENCY RETRACT:** Allows the user to retract the jacks when there is a false ALL UP light. The jacks will retract and override the ALL UP light. The button must be pressed and held until all jacks are retracted and the control panel automatically turns OFF.

## Programming the System

1. Press the POWER button to turn the panel/system ON. LED beside the button will illuminate. (System will NOT OPERATE with the ignition key ON).
2. Let the system run through the diagnostic mode (lights will flash clockwise around the green foot).

3. When in MANUAL mode, each leveler may be operated individually.
  - FRONT operates right front
  - RIGHT operates right rear
  - REAR operates left rear
  - LEFT operates left front
4. When using this feature it is important to level the coach by using two levelers at a time or together. For example, right front and right rear. as this puts less stress on the frame.
  - To retract individually, press and hold the RETRACT button and the desired jack button together.
  - To retract all jacks, press and hold MANUAL until the light goes off, then press RETRACT.
5. When using the AUTOMATIC feature, simply press the AUTO LEVEL button and let the system operate itself. It is important at this time there is NO MOVEMENT IN THE COACH. This process will take 1-3 minutes.
6. To retract the levelers simply press the POWER button and turn the system ON, and press RETRACT.

### Programming/Reprogramming the Automatic Leveling System

1. Press the POWER button to turn the panel/system ON.
2. Let the system run through its diagnostic mode (lights flash clockwise around the green foot).
3. When the lights stop flashing, push the button labeled "FRONT" 5 times.
4. Press the button labeled "REAR" 5 times.
5. All lights on the panel will begin to flash. This means you have reached "zero mode" in the system.
6. At this time you can operate each corner or pair of levelers individually.
  - FRONT operates right front
  - RIGHT operates right rear
  - REAR operates the left rear
  - LEFT operates the left front

## NOTE

Keep in mind the twisting/flexing of the vehicle's frame. **Try to operate jacks in pairs when possible.**

Once the coach is level, a new program can be stored into the leveling sensor (brain box). Press the RETRACT button (3) times. The AIR DUMP light will be the only light flashing. It will flash for 20 seconds then shut off and the green foot will start flashing. The leveling sensor is now (re)programmed. The system will use this new setting as the new "zero" point.

If you do not want to store the new program, turn the panel OFF (press POWER).

### Low Battery Voltage

If the FRONT and REAR lights are flashing on the display, and all of the buttons are locked up on the control panel, your battery voltage has dropped too low and the system is locked up. There is no

automatic reset for this condition. It must be done manually.

First make sure your battery level is back up to normal voltage.

Remove the (4) screws from the control panel and remove the panel. On the back side there is a 6 pin connector. Unplug the (6) pin connector from the back of the control panel for 30 seconds. Plug it back in and the panel will now reset. Reinstall the panel with the (4) screws.

### LIPPERT LEVEL UP® MOTOR HOME LEVELING SYSTEM (IF SO EQUIPPED)

**⚠ WARNING ⚠** (See page 28)

Your recreation vehicle may be equipped with a 4-point automatic leveling system. The control panel is typically located inside the entrance door or in an outside basement compartment.

The following is an overview of the system to be used as a quick reference. For detailed operating and safety instructions, refer to the manufacturer's owner's manual. Depending on your model, the system may vary slightly from the following instructions. Familiarize yourself with the operating and safety instructions prior to using the leveling system.

Prior to operation, make sure the following conditions are met:

- The recreation vehicle is parked on a reasonably level surface. EXCESS ANGLE will appear on the LCD display if the coach is 3.5° out of level front to rear or side to side. Refer to error modes in the OEM operating manual in your warranty packet.
- All pets, persons and property are clear of the unit while in operation.
- Battery should be fully charged or unit plugged into shore power.



### Leveling control panel callouts

**UP ARROW:** scrolls up through the menu on LCD

**DOWN ARROW:** scrolls down through the menu on LCD

**ENTER:** activates modes and procedures indicated on LCD

**RETRACT:** places leveling system into retract mode. Manual Mode ONLY. Press and hold down for (1) second to initiate auto retract.

**LCD display:** displays procedures and results

**AUTO LEVEL:** places leveling system into auto level mode

**FRONT JACK BUTTON:** activates both front jacks in manual mode

**LEFT JACK BUTTON:** activates left leveling jack(s) in manual mode

**RIGHT JACK BUTTON:** activates right leveling jack(s) in manual mode

**REAR JACK BUTTON:** activates both rear jacks in manual mode

**POWER BUTTON:** turns leveling system on and off

# VEHICLE OPERATION

## Auto Level Sequence

### NOTE

Zero Point Calibration **MUST** be set before starting the Auto Level sequence.

1. Begin with a manual leveling sequence to get the vehicle to the desired level point
2. Activate the Level Zero point configuration mode as follows:
  - Turn the panel OFF.
  - Press the FRONT switch 10 times.
  - Press the REAR switch 10 times.
  - A tone will sound and the display will read ZERO POINT CALIBRATION.
  - Press ENTER to set the zero point.
3. Screen will display Zero Point Stability Check and PLEASE WAIT.
4. Tone will sound and the screen will display ZERO POINT SUCCESSFUL.
5. Control will turn OFF.

### For Diesel Units with Air Bag Suspensions ONLY

The leveling control will automatically detect an air bag system.

If the unit does not use air bags, the display will read "NO" for air bag control.

If the display reads "NO" but an air bag system is present on the unit:

1. Confirm harness is connected properly.
2. Run Auto-Level function.
3. Recalibrate the Zero Point.
4. If the air bag system is still not being detected, contact the OEM for further information.

### User Alarm Mode

If the alarm system detects that the park brake has been disengaged while at least one jack is not fully retracted and the sensor value changes in any axis more than a predefined amount, the panel will signal an error.

When in alarm mode, all LEDs will flash and buzzer will beep. The Status LEDs will show the system status.

The system performs an automatic retract. No other features are available in this mode.

### Miscellaneous

- The system automatically shuts down after (4) minutes of no operation. To reset the system, the coach ignition **MUST** be turn off, then back on, and the power button on the Control Panel **MUST** be pressed again.
- Auto leveling cycle cannot be started until all jacks are fully retracted. Verify jacks are retracted before attempting to auto level. (Unit will perform a full retract automatically if jacks are down on the request of an auto cycle.)
- System will refuse any operation when a low voltage condition is present.

- System will automatically alarm and retract if the park brake is disengaged and jacks are not retracted with any change in sensor readings. In alarm mode, the only available feature is to retract all jacks.

### NOTE

- WAIT display shows the status of Air/Auxiliary features.
- The LEDs blink differently when in special controller modes (error, alarm, and configuration). Recognizing these modes is important. Excess angle LED blinks whenever the Y axis (vehicle length) is over 5 degrees from programmed level point.

### Low Voltage Signal

1. The vehicle requires 12.7V DC to operate in the AUTO mode. If voltage is too low, screen displays LOW VOLTAGE. If voltage drops below 12.7V DC, the system will only operate in MANUAL MODE and continues to display LOW VOLTAGE.
2. Minimum Voltage – If voltage drops below 9.5 V DC during AUTO or MANUAL operation LOW VOLTAGE will appear on display and system stops operating.

### Automatic Leveling Procedure

### NOTE

Pressing any button during an AUTO LEVEL sequence will abort auto leveling.

1. Push power button (right corner). System is operational and electronic level lights become active.
2. Check that the Control Pad ENGAGE PARKING BRAKE is engaged.
3. Press the AUTO LEVEL button to begin the automatic leveling cycle.
4. Push the power button to de-energize the system.

### Manual Leveling Procedure

### NOTE

When leveling your coach, the coach should be leveled from FRONT to REAR first (steps 2-4). When it is level FRONT to REAR, level the coach LEFT to RIGHT (step 5).

1. Press power button on control panel. System is operational and power light will be lit.
2. Press DOWN ARROW to display MANUAL LEVEL on the display. Press ENTER to set.
3. Press FRONT button until jacks contact the ground and lift front of the coach 1 to 2 inches.
4. Press REAR button until jacks contact the ground and lift the rear of the coach. Keep the button depressed until the level indicator displays level.
5. Press LEFT or RIGHT button. If level indicator is toward left of coach, press RIGHT button. If level indicator is toward right of the coach press LEFT button. Keep the button depressed until level indicator displays level.

## NOTE

The right and left jacks are used to level the coach side to side. Pushing LEFT on the control panel will extend both left jacks. Pushing RIGHT will extend both right jacks. Jacks always work in pairs; both front, both right, etc.

6. Repeat steps 2 through 5 if needed.
7. Turn power off to the leveling system by pressing the power button.
8. Visually inspect all jacks to ensure all shoes are touching the ground. If one of the rear jack shoes not touch the ground, press the corresponding LEFT or RIGHT button to lower the non-compliant jack to the ground.

### Jack Retract Procedures

1. Press the power button to energize the system. LCD screen will display JACKS DOWN.
2. Press DOWN ARROW to display AUTO RETRACT on the screen.
3. Press ENTER to begin automatically retracting the jacks.

## NOTE

To stop retracting the jacks, turn the system off and back on again by pressing the power button twice. The coach can then be manually leveled by following steps 1-5 in the Manual Leveling Procedure section above. Press ENTER to acknowledge.

4. When the JACKS DOWN display goes off, press the power button on the Control Panel to de-energize the system. After a brief visual inspection around the coach to verify the jacks are all fully retracted, you may proceed to travel.

## NOTE

To retract in the MANUAL mode, press the RETRACT button until it lights. By pressing any of the JACK buttons (LEFT, RIGHT, FRONT, REAR) the jacks will retract in pairs (i.e. FRONT retracts both front jacks, etc.).

5. AUTO RETRACT can also be commenced by pressing and holding the RETRACT button for 1 second.

## NOTE

In cold weather operation, always check to make sure all jacks, slide rooms and steps are fully retracted before travel.

### Jacks – Manual Override

In the event the jacks will not extend or retract there is a manual procedure where the jacks can be overridden with the use of a hex wrench. For specific instructions on the override procedure refer to the manufacturer's owner's manual found in your warranty packet.

### Drive Away Protection System

If the ignition is in the "RUN" position, jacks are down, and the operator releases the parking brake, all indicator lights will flash and the alarm will activate. The system will then automatically retract

the jacks until the jacks are fully retracted or the operator resets the parking brake. The power unit will also operate to keep the jacks retracted in the event the leveling system loses pressure as the coach is being driven.

### Jacks Down Alarm

The Leveling System is designed to sound an alarm and illuminate the control panel in the event of (2) possible scenarios:

- A "RETRACT" hose leaks.
- The pressure holding the jacks in the retracted position falls to approximately 1500 PSI.

If the alarm sounds and the control panel illuminates and flashes while driving the vehicle:

- Immediately find a place to pull vehicle off roadway.
- Set the parking brake.
- Inspect all jacks, hoses and valves for leaks

If no leaks are observed:

- Turn the control panel ON by pressing the power button.
- Press RETRACT ALL JACKS button
- Wait until "JACKS DOWN" light and alarm turn off.
- Inspect jacks. If jacks are retracted and no leaks are observed, vehicle can be driven.
- For prolonged travel to a service center, be sure to stop and check the disposition of the leveling jacks every so often to make sure they are not extending.

### Recommended Fluid

The leveling system is pre-filled and primed to operate direct from the manufacturer. Type "A" automatic transmission fluid (ATF) will work. ATF with Dexron III or Mercon 5\* or blend of both is recommended by the manufacturer.

Troubleshooting information, error codes, and manual override of the power jacks can be found in the Lippert Level UP® Motor home Leveling Owner's Manual found in your warranty packet, or contact Lippert Customer Service or your dealer for additional help.

### EMERGENCY STOPPING

**⚠ WARNING ⚠** (See page 27)

Always carry road flares or reflective warning signs. Pull off the roadway as far as possible for emergency stopping. Turn ON your vehicle hazard warning flashers. If traveling at night, use three red warning indicators such as flares, reflectors or lanterns as required by the Uniform Vehicle Code and Model Traffic Ordinance as follows:

1. Place the first warning indicator on the traffic side of the recreation vehicle, directed at the nearest approaching traffic.
2. Place the second warning indicator 100 feet behind the recreation vehicle in the center of the lane and toward approaching traffic.
3. Place the third warning indicator 100 feet in front of the recreation vehicle in the center of the lane and away from the traffic approaching from behind.

## NOTE

Curves and/or hills may affect the safe placement of warning indicators.

# VEHICLE OPERATION

## EMERGENCY TOWING

**⚠ WARNING ⚠** (See page 27)

If your motor home ever needs to be towed, refer to the instructions in your Chassis Guide. Please contact an emergency road service provider or a qualified service facility for assistance.

Make sure the road service technician reads and is familiar with the information contained in your Chassis Guide regarding emergency towing.

## FRONT AXLE TIRE ALIGNMENT

The term alignment refers to both the adjustment angles on the steering axle and suspension and tracking of the rear axle. Steering components, suspension, wheel bearings and even proper loading will affect the alignment.

We recommend you have the front suspension and steering alignment checked and adjusted after you have fully loaded the vehicle as part of the vehicle maintenance. Thereafter, it is your responsibility to have the alignment inspected periodically to maintain vehicle steering performance and prevent uneven tire wear as part of your normal maintenance.

After this road test has been completed, front-end alignment and/or vibrations will not be covered as part of the new vehicle limited warranty.

## NOTE

Always have the alignment checked and adjusted by a qualified shop with the proper equipment to handle heavy vehicles.

A road test by the dealer should be included as part of the pre-delivery inspection. The dealer can check for and correct any steering problems before you take delivery.

Follow the Chassis Guide maintenance instructions for the front and rear axle for wheel and suspension maintenance, including the brakes and wheel bearings. Contact your Chassis manufacturer for assistance.

## WHEEL LUG NUTS/WHEEL LINERS

**⚠ WARNING ⚠** (See page 29)

Torque is the amount of rotating force applied to a lug nut, and can only be achieved by using a properly calibrated torque wrench and socket. Do not use a 4-way socket or any other type of wrench that does not measure the actual pressure applied to the lug nut.

## NOTE

The proper method of tightening wheel lug nuts is with a torque wrench, not with an impact wrench or by hand. Because of the importance of having proper torque on the wheel lug nuts, you should always have the wheels mounted and properly torqued by a qualified technician using the proper tools.

After your first trip, check the wheel lug torque periodically for safety according to your Chassis Guide. If you suspect the wheel lug nuts have loosened at any time, have them checked and torqued to the proper limits immediately.

## Lugs should be checked:

- After winter storage
- After a wheel removal
- Before starting a trip
- Following extensive braking.
- **Check and re-torque after the first 10, 25 and 50 miles (16, 40 and 80 kilometers). Thereafter, check and maintain the torque according to the listed torque values.**

Refer to the Chassis Guide for torque guidelines.

## Wheel Lugs

If you suspect or notice the wheel stud bolts are cracked or broken, they must be replaced, along with adjacent bolts that have probably also been weakened due to the additional stress placed on them.

## Aluminum Wheels (if so equipped)

Clean the aluminum wheels with a cleaner that is designed for use on aluminum and apply an appropriate protection agent. Do not use abrasive cleaners. Wheels exposed to sea water or road chemicals should be cleaned as soon as possible. Be sure to use a sponge or chamois leather (brushes may damage the aluminum wheel surface).

## NOTE

If your motor home is equipped with aluminum wheels, only the outer dual wheels are aluminum, the inner duals are steel wheels.

## CHANGING A TIRE

**⚠ WARNING ⚠** (See page 27)

If you experience a flat tire on your motor home while driving, gradually decrease your vehicle speed (if possible), and move the motor home to a safe place on the side of the road. Contact your road service provider (if applicable) or a qualified service facility for assistance. **Do not attempt to change the tire or jack the motor home up yourself;** this is why a jack and a spare tire have not been included with the motor home.

Make sure the road service technician reads and is familiar with the Chassis Guide information regarding changing the tires. Make sure the wheel lug nuts have been tightened to the proper torque as outlined in your Chassis Guide.

## Tire Pressure

**⚠ DANGER ⚠** **⚠ WARNING ⚠** (See page 26) & (See page 27)

**You must follow the manufacturer's inflation guidelines for maximum load capacity; under-inflation is just as dangerous as over-inflation.**

Proper inflation should be monitored closely. Failure to do so could result in the overheating of a tire causing a blowout. Inflation pressure should be as recommended by the tire manufacturer or as the federal label for the recreation vehicle indicates.

When you are using your Recreation Vehicle, check inflation pressure weekly. Pressure should be checked when the tires are cold. During travel, tires heat up and pressure increases. **Do not bleed air from hot tires or your tires may then be under-inflated.**

## NOTE

Cold tire inflation pressure is defined as a tire that has not been used for three or more hours, or has been driven less than one mile. Tire inflation pressure of a hot tire may show an increase of as much as 6 psi over a cold tire.

## TIRES

**CAUTION** (See page 29)

Read and understand the following before taking your first trip in your RV.

Routine maintenance on your RV is important. **To ensure your tires are operating safely, regular inspection of the tires and checking tire pressures is absolutely mandatory.**

Alignment, balance and bearing wear will affect tire wear. Make sure to look for cracking, bulging, uneven tread wear, etc.

### Tire Wear Diagnostic Chart



Center Wear	Edge Wear	Side Wear	Toe Wear	Cupping	Flat Spots
Cause					
Over inflation	Under inflation	Loss of camber or overloading	Incorrect toe-in	Out of balance	Wheel lock-up & tire skidding
Action					
Adjust tire pressure to particular load, per tire catalog.	Adjust tire pressure to particular load, per tire catalog.	Insure load does not exceed axle rating. Align at alignment shop.	Align at alignment shop.	Check bearing adjustment & balance tires.	Avoid sudden stops when possible and adjust brakes.

## AWNINGS

**WARNING** **CAUTION** (See page 28) & (See page 29)

### Awning Care

Keep your awnings clean and in good condition to prevent costly repairs.

- Keep the awning fabric clean. For detailed cleaning information, refer to the manufacturer's owner information.
- Do **not** use insecticides or other sprays near the awning fabric. These can cause stains, and could adversely affect the fabric's ability to repel water.
- Do **not** expose the awning to adverse environmental conditions, corrosive agents, or other harmful conditions.

- Do **not** allow the corner of the entry door to contact the awning fabric. Otherwise, premature wear or tearing of awning fabric could occur.
- **Never** close the awning (for storage) when wet. The combination of moisture and dirt could result in mildew, discoloration, and stains. If it is necessary to roll up awning (temporarily) while it is wet, make sure you roll it out and let it dry (as soon as conditions allow) before rolling it up again.
- Do **not** allow dirt, leaves, or other debris to accumulate on the awning, which could cause abrasion and stains. Mildew could grow on dirt and organic debris, causing permanent discoloration, stains, and odors to the awning fabric.
- Do **not** use strong chemicals or abrasives to clean parts, as their protective surfaces will be damaged. Clean awning hardware (as needed) with a mild surface cleaner.
- Apply silicone spray lubricant as needed to the moving parts on the fabric roller tube assembly.
- Lubricate all pins and sliding surfaces of the arm assemblies with silicone spray, as needed.
- Do **not** use abrasive or corrosive cleaners, mildew removers, or hard bristle brushes on the awning fabric.

Vinyl awning fabric is durable and water resistant. Wrinkling is a normal characteristic, which may be more noticeable when the awning is retracted, and after prolonged periods of stowage (rolled up). Leave the awning open during warm weather to minimize wrinkling. A slight "travel line" may appear where the door roller (if installed) contacts the fabric. This is normal and does **not** affect the integrity of the fabric.

To clean the fabric:

- Open the awning.
- Mix 1/4 cup soap with five gallons of fresh water. Always use a natural soap, not a detergent. The water should be cold to lukewarm, never more the 100° F.
- Liberally drench the fabric with cleaning solution.
- Close the awning and allow the cleaning solution to soak for five minutes.
- Open the awning and thoroughly hose off the top and bottom of the fabric with clean water. Repeat if necessary.
- Remove the solution COMPLETELY from the awning fabric.
- Make sure the fabric is dry before closing the awning. Air-dry only. Never apply heat to the fabric.

Your recreation vehicle may include the following options:

- Slide out awnings
- Power awning over entrance door
- Power patio awning

## VEHICLE OPERATION

### Power Awnings

Depending on model, each power awning may have its own control switch or there may be a single button system. Pressing and holding the switch will extend or retract the awning. The awning will stop when the switch is released.

### NOTE

Do not overextend the awning. If the awning or awning skirt show signs of overextending, retract the awning until it is in the appropriate position.

- Most power awnings give you the ability to adjust the awning pitch (slope). This will help with water runoff and pooling. When adjusting the awning scope, be aware of entrance door and window clearances. Coming into contact with a door or window can damage or tear the awning fabric.
- Before retracting the awning, make sure there is not pooled water or debris on the awning.
- When preparing to travel, make sure the awning is completely retracted and secured. Turn off any light strips (if applicable).
- Make sure all power sources to the awning have been disabled. Test the awning prior to leaving to make sure it does not extend.

Most power awnings have a manual override in the event the awning will not retract.

Refer to the manufacturer's user guide for detailed safety, operating and troubleshooting information.

### CAMPSITE HOOK-UP

- Refer to Electrical Systems section before connecting the shore line power cord (when using full hook-up) OR before starting the generator (if equipped) or operating the vehicle on 12-volt power when dry camping.
- Refer to Fuel & Propane System section before using the LP system. Open the LP gas tank valve (if so equipped) slowly. There may be air in the lines and five to thirty seconds of time is needed to bleed air before LP vapor fills the lines.
- Refer to Plumbing Systems section before connecting the fresh water supply or turning ON the water pump or water heater.
- When using full hook-up, connect the sewer hose to the campsite sewer hook-up.
- If applicable, start the refrigerator and the cooling or heating system.

### NOTE

For extended dry camping, management of all your resources is essential. Check your battery levels and conserve battery power, use it sparingly.



## VEHICLE OPERATION DANGER

### CHILD SAFETY RESTRAINT SYSTEMS (See page 19)

- Never allow a passenger to hold a child on their lap while the motor home is moving. The use of safety seats for children are required when transporting a child in your motor home. All child age and weight guidelines as specified by law should be strictly adhered to.
- Rear facing child seats or infant carriers, or child booster seats should never be placed in the front seats of the motor home.

**Failure to follow these guidelines can result in serious injury or death.**

### TIRE PRESSURE (See page 24)

**Failure to follow proper inflation guidelines may result in tire failure, which, under certain circumstances can cause loss of vehicle control or accidents that may result in property damage, bodily injury and/or death.**



### TOWING BEHIND YOUR MOTOR HOME (See page 17)

- **Total weight of your motor home and any trailer or vehicle towed by it must not exceed the GCWR.** Do not assume that you can tow a vehicle that happens to be within the capacity of the hitch. By doing so, you may exceed the total GCWR of the motor home.
- **The total weight of your motor home (including cargo, passengers, fluids, etc.) in addition to the vertical (tongue) weight must not exceed the GVWR and/or any GAWR.** Once again, do not assume that you can tow a trailer or vehicle that happens to be within the vertical (tongue) weight capacity of the hitch. By doing so, you may exceed the GVWR and/or GAWR of the motor home.
- **Your motor home chassis braking system is rated for operation at GVWR, NOT GCWR.** Any trailer or vehicle being towed by your motor home must have adequate brakes as required by all state (or province) and local regulations for towing with your motor home, including areas you may be traveling through. **Failure to follow the towing guidelines may result in property damage or injury.**

### CHILD SAFETY RESTRAINT SYSTEMS (See page 19)

- Improper installation or failure to properly secure a child restraint may result in failure of the restraint.
- Follow the child restraint manufacturer's directions exactly when installing an infant or child restraint. Be aware of all warnings and safety information included with any infant or child safety restraint system.
- Never place a front or rear facing child restraint in the front seat of a vehicle. A deploying passenger front air bag can cause death or serious injury to a child 12 years or younger, including a child in a child restraint. A child restraint should only be installed in a rear seat.
- To ensure proper safety belt fit, always use booster seats for children who are size and age appropriate. Refer to the governmental safety regulations for child sizing charts.

**Failure to follow these guidelines can result in serious injury or death.**

### EMERGENCY STOPPING (See page 23)

For personal safety, always stand off the road and out of the way of traffic.

### EMERGENCY TOWING (See page 24)

- Never allow anyone to go under the motor home while it is being lifted by towing equipment.
- Be aware of the strap locations. Misplaced straps could result in damage to the exterior of your unit. Damage resulting from misplaced straps is the responsibility of the towing company, and is not covered by the unit warranty.

### REAR VISION CAMERA (See page 20)

- Camera/monitor system aids in the use of, but does not replace vehicle side/rear-view mirrors.
- Objects in camera/monitor view are closer than they appear. When backing up, proceed cautiously and be prepared to stop.

### BOOTH DINETTE (See page 19)

The dinette table should be lowered and secured with the safety strap whenever adding a child safety seat to the dinette seat.

**Failure to follow guidelines can result in serious injury or death.**

### VEHICLE OPERATION (See page 17)

Your motor home chassis braking system is rated for operation at GVWR not GCWR

### CHANGING A TIRE (See page 24)

- The motor home is very heavy. Raising the motor home to replace the spare tire should only be done with extreme caution by a qualified technician. The vehicle could slip, causing personal injury or death. **DO NOT ATTEMPT TO DO THIS YOURSELF.**
- Do not use the hydraulic leveling jack system to support the motor home while under the vehicle or changing tires. The hydraulic leveling system is designed as a leveling system only. Do not use the hydraulic leveling jack system as a jack or in conjunction with a jack. It is highly recommended that, should a tire change be required, it be performed by a knowledgeable, trained professional. **Attempts to change tires while supporting the motor home with the hydraulic leveling jack system could result in damage to the motor home and risk causing serious injury or death.**
- When replacing a tire, Replace it with a tire of the same size and specifications (refer to your Chassis Guide for assistance).

### TIRE PRESSURE (See page 24)

It is recommended that the tire pressure be checked at the beginning of each trip to obtain the maximum life of the tire. Follow the instructions listed on the Federal Certification label, to determine the correct tire pressure. Under-inflation may cause tire failures and swaying resulting in loss of control, injury, death or property damage.



#### LIPPERT LEVEL UP (See page 21)

**Failure to act in accordance with the following warnings may result in serious personal injury or death!**

- **Never lift the recreation vehicle completely off the ground.** Lifting the RV so the wheels are not touching the ground will create an unstable and unsafe condition and may result in serious personal injury or death.
- The leveling system is designed only for leveling the unit and should never be used to provide service for any reason under the recreation vehicle such as changing tires or servicing the system. It is not recommended that you change a tire yourself.
- Ensure all jack locations are clear of debris, obstructions or depressions.
- When parking the RV on extremely soft surfaces, utilize the load distribution pads under each jack.
- People and pets should be clear of the coach while operating the leveling system.
- Keep hands and other body parts clear of fluid leaks. Oil leaks may be under high pressure and can cause serious skin penetrating injuries.
- The use of the electronic automatic leveling system to support the coach for any reason other than which it is intended is prohibited and will violate terms of the limited warranty.

#### SEAT BELTS (See page 18)

**Seat belts should always be worn by anyone who drives or rides in this vehicle.**

- Never use one seat belt for more than one occupant. Never carry more people in the motor home than there are seat belts.
- Only seats equipped with seat belts are to be occupied while the vehicle is in motion. While traveling, do not occupy beds or any seats that do not have seat belts.
- Be sure to lock all doors before driving. Locking the doors and using the provided seat belts will minimize the risk of injury or ejection in an accident.
- If you are pregnant, consult your health care professional for advice on seat belt use.

#### AWNINGS (See page 25)

- Awnings must be closed (and secured) while the RV is in transit.
- Keep clear of arm assemblies while opening, adjusting or closing the awning. Failure to obey this caution could result in injury and/or property damage.
- Always operate the awning according to the instructions.
- Periodically check that the fasteners are tight (tighten if necessary).
- Keep the awning fabric and arms clean.

#### ENTRANCE STEP (See page 18)

**LOOK BEFORE ENTERING OR EXITING YOUR MOTOR HOME!**

- When opening the door from the outside, make sure you are not obstructing the path of the entrance step. Step deployment takes approximately two seconds. Keep hands and fingers clear while extending or retracting.
- **Look before you exit. Make sure the steps are fully deployed before exiting the motor home.** Stepping on a partially extended step can cause damage to the step frame.

#### BIG FOOT/QUADRA LEVELING SYSTEM (See page 20)

**FAILURE TO ACT IN ACCORDANCE WITH THE FOLLOWING WARNINGS MAY RESULT IN SERIOUS PERSONAL INJURY OR DEATH!**

- The use of the electronic automatic leveling system to support the coach **for any reason other than which it is intended** is prohibited and will violate terms of the limited warranty.
- **Never lift the recreation vehicle completely off the ground.** Lifting the RV so the wheels are not touching the ground will create an unstable and unsafe condition and may result in serious personal injury or death.
- The leveling system is designed **only** for leveling the unit and should **never** be used to provide service **for any reason** under the recreation vehicle such as changing tires or servicing the system. It is **not** recommended that you change a tire yourself.
- Ensure all jack locations are clear of debris, obstructions or depressions.
- When parking the RV on extremely soft surfaces, utilize the load distribution pads under each jack.
- People and pets should be clear of the coach while operating the leveling system.
- Keep hands and other body parts clear of fluid leaks. Oil leaks may be under high pressure and can cause serious skin penetrating injuries.



#### DRIVER AND PASSENGER SEAT (See page 18)

- Do not adjust the seat while driving. After adjusting the seat, make sure that it is locked in position. To ensure that the seat is locked securely, try to move the seat forward or backward without using the adjusting lever or button. Do not put packages, pets or other objects between the driver's and front passenger co-captain's seat.
- **If equipped with reclining seats:** to minimize the risk of personal injury in the event of a collision or sudden stop, always keep both the driver's captain and passenger co-captain seat backs in a nearly upright position while the motor home is moving. The protection provided by the seat belts may be reduced significantly when the seat back is reclined. Reclining the seats while the motor home is moving may result in serious injury.
- **If equipped with power seats:** keep hands and feet clear of the power seat while in operating the power feature.

#### VEHICLE DASH (See page 19)

Do not set anything on, or attach anything to, the instrument panel or dash. Do not attach anything to the steering wheel cover. Failure to follow these warnings may restrict the driver's visibility or cause an object to strike and injure an occupant in the case of a collision or sudden stop.

#### WHEEL LUG NUTS (See page 24)

- Check and tighten the wheel lug nuts regularly to ensure they did not loosen during travel. Refer to your Chassis Guide for torque recommendations.
- Failure to tighten and maintain wheel lug nuts to the proper torque specification, could allow the wheels to come off while driving, resulting in serious injury or property damage in the event of a collision or loss of vehicle control.



### VEHICLE OPERATION CAUTION

#### TOWING BEHIND YOUR MOTOR HOME (See page 17)

Do not install a frame equalizing type hitch on your motor home.

#### ENTRANCE DOOR (See page 18)

Make sure the entrance door is completely closed and locked when traveling. Locking the door helps prevent it from opening unintentionally and keeps intruders from your recreation vehicle.

#### ELECTRIC REAR STABILIZER CONTROL (See page 20)

Do not move the motor home while the jacks are still in contact with the ground or extended. Damage to the vehicle could occur.

#### BIG FOOR/QUADRA LEVELING SYSTEM (See page 20)

Before driving, it is recommended you walk around the coach and inspect all levelers to make sure all are retracted. Failure to do so may result in damage to the leveling system or the motor home.

#### TIRES (See page 25)

Tire wear should be checked frequently. Once a wear pattern becomes firmly established in a tire it is difficult to stop, even if the underlying cause is corrected.

#### OUTSIDE REARVIEW MIRRORS (See page 19)

Adjust the outside rearview mirrors before driving.

#### AWNINGS (See page 25)

The effects of wind and rain on an awning are unpredictable and can cause severe damage to the awning and/or the recreation vehicle. **Retract the awning if:**

- If wind or extended periods of rain are expected.
- If you leave the RV unattended for a length of time, to avoid unexpected climate conditions.

# SECTION 5: SLIDEOUT SYSTEMS



## ELECTRIC SLIDE ROOM(S) (IF EQUIPPED)

**⚠ WARNING ⚠** **⚠ CAUTION ⚠** (See page 34) & (See page 34)

The mechanical components of the slide out are gear driven. Electric powered slideout room systems have a manual override to allow you to extend or retract the slideout room(s) in case of a power loss.

**Make sure you have sufficient power available before operating your slideout system.**

Level the RV prior to extending the slideout.

Slideout switches are typically located inside the RV, either in the command center or on the wall. If your RV is equipped with a touch screen control system, your slide room controls will be built into the touch screen system.

### General Slideout Operation

- **The auxiliary battery must be fully charged and connected. If possible, the RV should be hooked up to 120-volt AC power so the converter operates.**

In order to operate the slideout rooms, the Park Brake must be set and/or ignition off. To extend the slideout rooms, press and hold "EXTEND" on the extend/retract switch. The slideout rooms will not extend unless this switch is held down. Release the switch **immediately** once it is fully extended or retracted do not let it go beyond the stop. Press and hold "RETRACT" on the extend/retract switch again to reverse the process.

If the slideout rooms will not extend or retract, contact Customer Service or a reputable dealer service facility. **Do not attempt to service the slideout system yourself.**

After the slideout is extended, visually inspect the slideout and the surrounding area to make sure the slideout has extended properly and has adequate clearance from any outside obstructions.

If the slideout is equipped with rubber seals, verify that the corners of the black rubber seal are set up correctly. The seal corners are cut at a 45° angle. The top of the outside seal must overlap the side of the seal to avoid the possibility of water penetration. On the inside seal, the side seal should overlap the top.

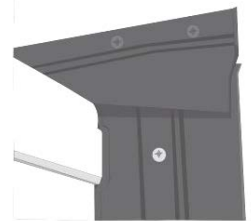

Slideout Overlap-Outside

## NOTE

For long-term storage it is recommend the room be closed (retracted).

### General Slideout Troubleshooting Checklist

## NOTE

For additional troubleshooting information, refer to the specific slideout system detail.

**Slideout Systems** - Your RV may be equipped with one or more of the following slideout systems.

### **Schwintek In-Wall Slideout System**

The in-wall slideout system requires no maintenance or adjustments. This system has two vertical columns with a drive motor located at the top of each column. The right and left motors are synchronized by a circuit board.

## NOTE

Do not operate the switch after the room is fully extended or retracted as damage can occur to the motor and/or switch.

To operate the slideout using a wireless remote (if so equipped):

- Press the on/off button to power on the remote.
- Press the corresponding button of the slideout you want to operate.
- Press and hold the (extend/retract) arrow button to move the room in or out.
- Press the on/off button once more to power off the remote.

**ALWAYS** allow the controller to stop both motors before releasing the switch button.

**DO NOT** try to time the end of the stroke by releasing the button early.

## Maintenance

**⚠ WARNING ⚠** (See page 34)

This slideout system requires very little maintenance. It contains a pre-lubed bearing that is lubricated when the room is moved in and out. Do not spray oil or grease on the rails while the room is extended.

## Trouble shooting the in-wall slideout system

**Checking Fuses:** The in-wall slide requires a minimum 30-amp fuse. Check the load center for blown fuses and replace any if necessary. If the fuse blows immediately upon replacement, there is a problem with the wiring to the in-wall slide control box. **A qualified service person should be called to check and repair.**

**Obstructions:** Check both inside and outside for possible obstructions. Also check for smaller objects that may be wedged under the floor or in the sides of the unit. Remove any obstructions before proceeding.

**Error Codes:** When an error code occurs during operation, the board LEDs lights will indicate where the problem is. For motor specific faults the green LED will blink (1) time for motor #1 and (2) times for motor #2. The red LED will blink 2 to 9 times depending on the error code. Error codes are as follows:

- 2 times **Battery capacity is low** enough to drop below 6 volts while running.
- 3 times **Battery (low) voltage** is below 8 volts at the start of a cycle.
- 4 times **Battery (high) voltage** is greater than 18 volts.
- 5 times **Excessive motor current** (high amperage) also indicated by (1) side of the slide continually stalling.
- 6 times **Motor short circuit:** motor or wiring to motor has shorted out.
- 8 times **Hall signal not present:** encoder not providing a signal; usually a wiring problem.
- 9 times **Hall power short to ground:** power to encoder has been shorted to ground; usually a wiring problem.

The board will need to reset after an error code. Energizing the extend / retract switch will reset the board; energizing it a second time will return it to normal operation

**Low Voltage:** The in-wall slide controller can operate with as little as 8 volts; however, with lower voltages the amperage requirement is greater. Check the voltage at the controller and if it is lower than

11 volts, it is recommended that the battery be placed on a charger until it is fully charged. It may be possible to “jump” the RV battery temporarily to extend or retract the room. Consult Customer Service before attempting to “jump” the auxiliary battery.

**Only 1 Side Moving:** The slide room has a separate motor to operate each side of the room. If only one side is moving, with another person’s assistance, press the switch to extend or retract the room while pushing the non-moving side in the appropriate direction. On larger rooms it may be necessary to have 2 or more people pushing the room.

**Non-moving side moved manually:** Try to push the non-moving side in and out. If a motor shaft has broken it will be possible to move that side of the room several inches by hand. Larger rooms may require several people to push.

**Debris in the rack:** Check all 4 gear racks on the side of the room for debris.

**Status LEDs lights:** Locate the slide controller for the slideout in question. Check the status LED lights while pressing the slideout direction switch (in both the extend and retract mode).

## Manual override for the in-wall slideout

**⚠ CAUTION ⚠** (See page 34)

The slideout system comes with an “electronic” manual override. In event the slide out does not extend or retract follow these steps to override the system which should allow the slideout to be retracted.

## NOTE

Fuses for the slideouts can be found in the load center and may be designated as auxiliary or slideout motor.

1. Locate the slideout system controllers. There should be one for each slideout on the recreation vehicle. They are typically located on the forward wall or ceiling of a basement compartment. In some models they may be behind a cargo lined panel.
2. The malfunctioning controller should have a flashing red LED indicating a halt signal fault (will flash 8 or 9 times).
3. Press the “mode button” six times quickly, then press a seventh time and hold for approximately 5 seconds.
4. The red and green LED’s will flash indicating you are in override mode. Release the mode button.
5. Using either a wall or command center panel switch, press and hold the switch toward the word IN or RETRACT until the unit comes in completely. This will allow you to get the recreation vehicle to a service center to have the slideout malfunction diagnosed.

## Manually pushing in the slideout

1. Locate the slideout system controller.
2. Unplug motor 1 and motor 2 connectors at the bottom of the slideout controller. This releases the motor brakes for each motor.
3. The slideout room can now be manually pushed in. Larger rooms may require several people to push or pull them.

# SLIDEOUT SYSTEMS

- Keep both sides of the slideout relatively even while pushing/pulling.
- When the room is completely in, plug both motor connectors back into the control module. This will apply the motor brakes for road travel.

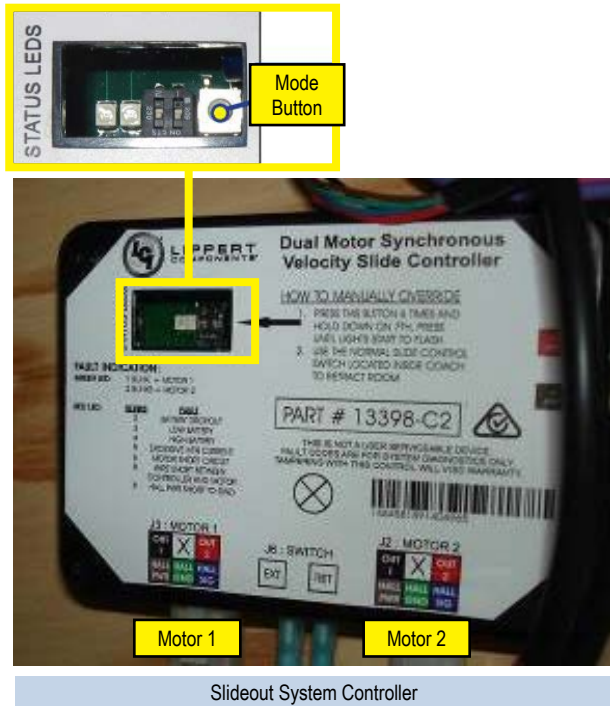

## Power Gear Below Floor Slideout System

**⚠ WARNING ⚠** (See page 34)

**Manual Override** - The slideout system is equipped with a manual override that allows you to extend or retract the room in the event of a loss of power.

**If the room does not move when the switch is pressed, check the following:**

- Make sure the slideout system is turned on.
- Battery is fully charged and connected.
- Transit bars have been removed (if so equipped).

**⚠ WARNING ⚠** (See page 34)

**If the room still does not move when the switch is pressed, follow the steps below to manually override the slideout room:**

1. Turn the Main Power OFF. The override will not work if it has power going to it. **Do not work on the system unless the battery is disconnected.**
2. Locate the slideout controller. There are two versions of the controller.
3. **Version 1**, unplug the 6 pin wiring harness from the controller.
4. **Version 2**, remove one of the motor leads, either the motor I or motor II lead from the controller.
5. Locate the slideout motor (**Fig. 1**) mounted to one of the slideout rails. Some models may require removal of the underbelly or cover to access the motor. In a bedroom slideout, it may be located under the bed.
6. Rotate the brake lever, on the backside of the motor, counter-clockwise (looking from the rear of the motor) about 1/8 of a turn to the released position. This will release the brake that holds the room in place.
7. Locate the manual override for the slideout system (**Fig. 1**).

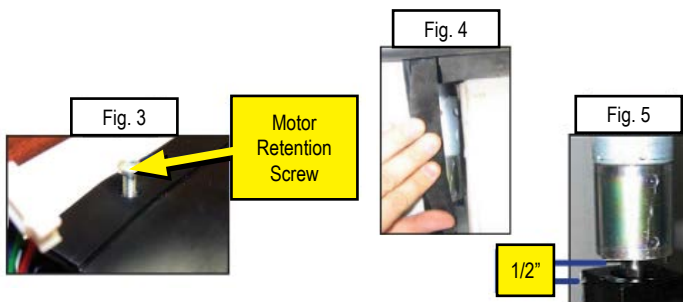

## Disengage motors, manually retract the room and travel lock

**⚠ WARNING ⚠** (See page 34)

1. Locate and remove the motor retention screw, which can be found near the top of each vertical column (**Fig. 3**).
2. Bend back the wipe seal and visually locate the motor (**Fig. 4**).
3. Pull the motor up until it disengages (about 1/2 inch).
4. Repeat this process for both sides of the slide room.
5. Physically push/ pull the room back into the opening; keep both sides relatively even.
6. The room must be travel locked to keep the room in place for road travel.

Refer to the Schwintek Slide Room Operation Guide for additional troubleshooting information, or contact Lippert at (866) 524-7821 or at [www.lci1.com](http://www.lci1.com).

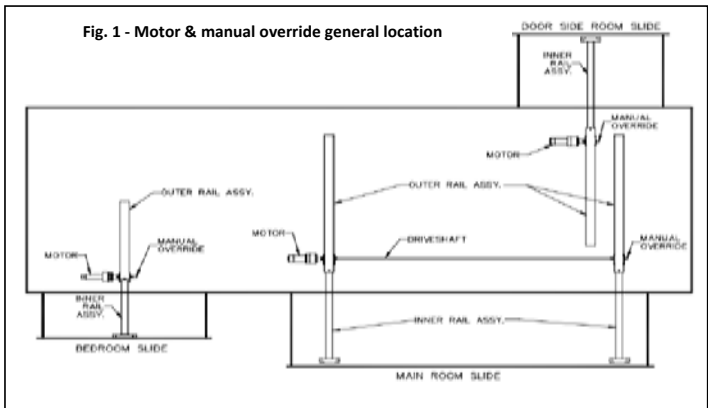

8. The room is now free to move. Using either a 5/8" or 3/4" wrench or socket, crank the room either in or out completely. If the slideout system is supplied with a gearbox override (optional), use the crank handle to move the room.
9. When the rooms is fully in or out have one person apply pressure to the wrench/ratchet and return the brake lever to its engaged position. This ensures the room is locked into a sealed position.

# SLIDEOUT SYSTEMS

10. Install the transit bars (if so equipped) to the slideout room and take the unit to an authorized dealer for service.

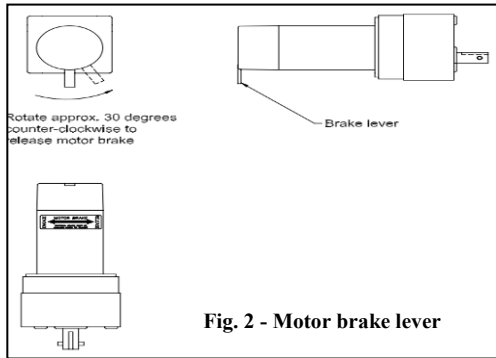

Fig. 2 - Motor brake lever

Refer to the Power Gear® Electric Slideout Operation Manual for detailed operation, safety and troubleshooting information.

## Power Gear Ram Slideout System Manual Override Procedure

The system has been equipped with 3/4" hex override couplers located on the drive component of the system. Due to the size and weight of some rooms, assistance may be needed to push the room in.



Motor Cover

Use the following steps to mechanically operate the room

1. Locate the ABS motor access cover for the slideout. This cover will be located inside one of the storage compartments under the slide room up at the top of the compartment.
2. Remove (4) screws holding the panel to the top of the compartment. Remove the cover.
3. Unplug the motor leads at the connector. Gray connector with red and black wires.

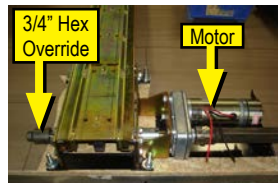

4. To release the motor brake you must depress the spring lock lever, which then allows you to pivot the brake lever, which in turn releases the brake. These parts are located inside the rubber boot wire tied over the motor. You must manipulate these parts **without** removing the rubber boot. **As noted on the side-by-side photo, removing this boot will void your motor warranty.** These photos will help you figure out how this works. The side-by-side photo (below) shows the spring lock lever and the brake lever.



5. The spring lock lever is a thin metal arm with a slight bend at the end, which will hold the brake lever in the released position.



6. The brake lever is the heavier thicker metal arm with the hole in the end.
7. The normal position for these two levers is to be parallel to each other as shown in the first side-by-side photo. The motor brake is engaged with levers side by side.
8. The brake lever is moveable; the spring lock lever is not moveable. To release the brake lever, you must push the bent end of the spring lock lever away from the brake lever; this will allow you to pivot the brake lever so it moves over on top of the spring lock lever. The bent end will hold the brake lever in the released position. (photo shows this "bend").
9. Once the brake motor is released, you will need to remove the skirting on the side of the slideout floor where the hex override is located.



10. Use a ratchet with a 3/4" socket (or wrench) to turn the hex override and manually move the slideout.
11. When the slideout is retracted, check to make sure you have a good seal, and replace the skirting on the slideout.

12. Return the brake release lever back to the "engaged" position (parallel to the spring lock lever). Pressing the bent end of the spring lock lever will allow the brake lever to be moved.

**DO NOT** remove boot. Removal of rubber boot will void manufacturer's warranty. Rubber boot removed from end of motor only to show brake lever and spring lock.

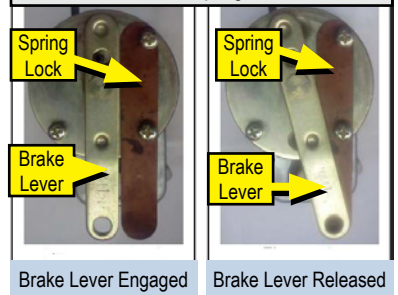

13. Plug the motor connector back in again.
14. Replace the plastic motor cover with the (4) screws removed previously.

15. Take the unit to an authorized dealer for service.

For further information, refer to the manufacturer's owner's manual.





### ELECTRIC SLIDE ROOM (See page 30)

- Make sure the interior slideout room path and the slideout room itself is clear of people and objects before operating.
- Keep away from the slide rails and gear assembly when the room is in motion. They may pinch or catch on loose clothing causing personal injury.

**Failure to follow these instructions could result in serious injury or death.**

### MAINTENANCE (See page 31)

Do not work on your system unless the 12-volt DC (auxiliary battery) and 120-volt AC electrical systems (shore line power cord) have been disconnected.

### TRANSIT BARS HAVE BEEN REMOVED (See page 32)

When the motor brake is disengaged the slideout room WILL NOT lock into place and will not be sealed. When the room has been manually retracted, be sure to install transit bars (if so equipped) and return the motor brake lever to its normal engaged position in order to seal and lock the room into position.

### DISENGAGE MOTORS, MANUALLY RETRACT... (See page 32)

**DO NOT MOVE THE RV UNLESS THE MOTORS ARE PLUGGED IN TO THE CONTROLLER AND THERE IS BATTERY POWER TO THE RV. THIS SETS THE BRAKES ON THE SLIDEOUTS TO PREVENT THEM FROM MOVING DURING TRANSIT.**



### ELECTRIC SLIDE ROOM (See page 30)

The following guidelines should be used when using your slideout room:

- The recreation vehicle **must be level** before operating the slideout room. Water leaks and other problems could result if the slideout is operated without leveling the RV.
- **DO NOT OVER EXTEND OR RETRACT THE SLIDEOUT ROOM.** Release the switch immediately once the room has been fully extended or retracted. Do not wait until you hear the motor stop. Over extending or retracting the slide out room may result in damage to the stop rod and bracket.
- **Do not place excessive weight** in the slideout room. It can cause the slideout room to malfunction and cause damage to the slideout.
- Additional support jacks are not needed under the slideout. Damage can occur to your slideout room from improper use of aftermarket support jacks.

### MANUAL OVERRIDE FOR THE IN-WALL SLIDEOUT ((See page 31)

**Call your dealer or Customer Service if:**

- During the override procedure the motors are not synchronized. Visually watch the room, and if one side is moving significantly slower than the other (or not at all).
- If the system stalls out before reaching end of stroke OR if the room does not close and seal tightly.

### POWER GEAR BELOW FLOOR SLIDE OUT (See page 32)

- Always disconnect battery from system prior to manually operating system. Failure to disconnect battery can cause electricity to back feed through the motor and cause serious damage to the system as well as void the warranty.
- **Use EXTREME CAUTION when extending/retracting the room using the manual override feature.** The gears can be stripped out if the room is manually retracted/extended to its fullest extent and the operator continues to rotate manual override. Damage can also occur to the slide components, slide room structure or trim components. Damages due to misuse of the manual override feature will void any and all claims to the Limited Warranty.

# SECTION 6: ELECTRICAL



## THE ELECTRICAL SYSTEM

**⚠ WARNING ⚠** (See page 48)

The RV electrical system is comprised of two independent electrical systems. One operates off of 12-volt DC power and the other off of 120-volt 60hz AC power. All installations have been made in compliance with industry standards applicable on the date of manufacture. Because the electrical equipment and associated circuitry are engineered into a dedicated system specific to your RV, do not make unauthorized changes or add fixed appliances to it. **Changes or additions made after delivery may result in a hazardous condition.**

Service and/or modification of the electrical system should only be performed by qualified electrical technicians using approved materials, components, and methods meeting current safety and code requirements. Consult your dealer's service department for assistance.

To read more about the various components incorporated into the RV electrical system, please refer to the information contained in your Warranty Packet.

Consult the Chassis Guide for information pertaining to the chassis drivetrain electrical system.

### Electrical System Maintenance

- Before working on the electrical system:
- Make sure the inverter/charger (if so equipped) is turned "off" before disconnecting batteries.
- Disconnect the shore power cord.
- If equipped with a generator, turn off the generator and disable the automatic generator start functionality.
- Turn off the battery disconnect switch (if so equipped).

- Turn off the 120V main circuit breaker.

Disconnect the negative 12VDC battery terminal from the battery.

## COMMAND CENTER

### Command Center Overview:

The command center, located near the entrance or in the living area, features various switches and controls tailored to different RV models.

### Panel Features:

- Fuel gauge and hour meter with fuel pump and station switches (if available)
- Red-lighted switches for water heater, generator, tank heaters, and cargo bed
- Light switches for various interior and exterior lights
- Controls for slideouts, awnings, auto-leveling, and power bunk bed lift
- Systems monitor displaying tank levels and battery charge status
- Inverter panel with power switch and display
- Speaker selector switch
- Touch dimmer switch for ceiling lights



Command Center Panel w/ Switch Modules

# ELECTRICAL

## Dimmer Functionality:

- Tap to turn ceiling lights ON/OFF
- Press to adjust brightness gradually
- Memory function retains last brightness setting when turned ON again.

## NOTE

If your RV model includes the 5 way/8 way remote control, the LIGHT button on the remote only controls the awning LED lights.

## FIREFLY SYSTEM (IF EQUIPPED)

Your RV is equipped with a Firefly touchscreen coach control system. The touchscreens (based on model and floor plan) offer a clean and simple interface for controlling different features or systems. Your particular model may not include every option or system.

The following systems/components **ARE** controllable from the touchscreen:

- Tank monitors
- Battery voltage for both house and chassis batteries
- Lighting (interior and exterior)
- Generator operation (start, stop, prime and preheat)
- AC and DC Power
- Water Pump, Water Heater
- Heating, Air Conditioning and vent fans
- Awnings and Slide-outs
- Settings for the touchscreen (background, etc.)

## NOTE

The touchscreen system may require periodic updates and/or downloads. The age of your device or hardware configuration changes may prevent your device from accepting or installing a new system update. If you receive notification that an upgrade is available, please contact Fire Fly Integrations for further information (<http://www.fireflyint.com>). Version number information for your touchscreen is found on the Settings screen of your touchscreen.

## JAYCOMMAND PLUS BMPRO SYSTEM (IF EQUIPPED)

The BMPRO system, as detailed in the BMPRO Owner's Manual, offers comprehensive control of various RV functions via a wall-mounted RV tactile or touch screen control panel.

### Features:

- Wi-Fi enabled for internet access and app updates (Models equipped with Touch Screen only)
- Smartphone, tablet, or smart device app available for download
- Bluetooth connectivity



Touch Screen Control Panel

## Controlled Functions:

- Connected interior and exterior lights
- Slide-out rooms
- Power awnings
- Generator (if installed)
- HVAC thermostat (Models equipped with Touch Screen only)
- Tank type gas and electric water heaters ( - tankless water heaters are not controlled)
- Tank levels (fresh water, black water, gray water)
- Battery levels
- Water pump



RV Tactile Control Panel

## Activating the Touch Screen Equipped System:

- The system automatically boots up when RV 12-volt power is turned "on". Touch any location on the touch screen surface to wake up system if RV 12-volt power is "on" and the touch screen isn't illuminated. Note: You may need to manually turn "on" the touch screen (if it was previously manually turned "off") using the on/off button located on the left upper corner of the touch screen bezel.
- To re-boot the complete BmPro system:
- Navigate to the "Diagnostics" page on the touch screen or JayCommand Plus mobile app and select "Reset Node" located at top of page
- Allow nominal 30 seconds for reset process to finish
- System is now active and ready to use

## Sidebar Control Buttons:

- Home Screen - Shows an overview of the key features of your RV: climate, lights, tanks, energy, and motors or quick start guide.
- Water Screen - Shows tank monitors (black, gray and fresh), water pump switch, gas and electric water heater switch (if RV equipped with tank type water heater), and switch for tank heaters (if RV equipped with tank heaters)
- Motors Screen - Shows controls for awnings, slide-outs, and towable model auto-leveling
- The app on your smart device automatically locks out the Motors screen on your device. You must swipe to unlock the screen in order to operate motors.
- Only one motor may be operated at a time.
- When a motor is in operation, motor control will be disabled on any other device running the App.
- Climate Screen - Shows a thermostat(s) and related controls used to operate RV heating, cooling, and cooling fan speed.

- Heating and cooling is only controlled through BMPRO on touch screen equipped models. One or more small sensors are located on the RV interior walls. These sensors provide room temperature feedback to the BMPRO system allowing it to adjust room temperature according to climate selections made on the touch screen control panel.
- Lights Screen - Turn connected lights “on” and “off” along with ability to dim certain lights Energy Center Screen - Shows generator “on” and “off”, AGS (auto generator start), battery levels, and fuel levels.
- Fans Screen - Shows bath fan on and off. (motorhomes only)

## General Settings Screen –

General Settings may be accessed by pressing the Settings icon (gear icon) located at the lower left corner in the touch screen or app home screen.

- Bluetooth Connection: Check, activate, or deactivate the Bluetooth connection between the Node and the touch screen.
- Preferences: Set preferred temperature (Fahrenheit/Celsius) and tire pressure (kpa/psi) units of measure.
- Energy Center Settings: Access the AGS Energy settings.
- Battery Levels: Check the battery condition of any installed BMPRO Bluetooth wall switch or temperature sensor. Battery Levels screen is also used to individually pair and unpair Bluetooth wall switches and temperature sensors.
- User Manual: After establishing WIFI connectivity a digital version of the BMPRO owner’s manual can be viewed on the system touch screen or BMPRO connected mobile device.
- On the HOME screen, press the Setting button (gear icon) located at the lower left corner in the touch screen or app home screen.
- Scroll down until you see USER MANUAL and tap to select.

## Unpairing Bluetooth Mobile Devices

Up to four Bluetooth devices can be paired to the BMPRO system: This includes the touch screen control panel (if so equipped) plus up to 3 additional mobile devices (for a total of 4). The Node must be cleared of ALL previously paired mobile devices before additional or replacement mobile devices can be paired. A single mobile device cannot just be replaced with another mobile device. To clear the Node of all paired mobile devices:

On the Touch Screen Home Screen press the Setting button (gear icon) located at the lower left corner in the touch screen

- Press Bluetooth Connection.
- Press Unpair RV
- The Node is now cleared of all connected devices.

From the RV tactile control panel

- Press and hold the Bluetooth Pair button for 20 seconds.
- The Node is now cleared of all connected devices.

## Pairing to the Node

Pairing the touch screen control panel to the node:

- From the BMPRO touch screen Home Screen press the Setting button (gear icon) located at the lower left corner in the touch screen
- Scroll down and select Bluetooth Connections
- Select Pair
- Follow the on-screen prompts to connect to the Node.
- The touch screen is now connected to the BMPRO System.

## Pairing the RV Tactile control panel to the node:

- Pairing between the RV Tactile control panel and node automatically occurs when the RV Tactile control panel is network cable connected to the node

## Pairing a mobile device to the node from the touch screen control panel:

- Launch the JayCommand Plus app on your mobile device
- From the BMPRO touch screen Home Screen press the Setting button (gear icon) located at the lower left corner in the touch screen
- Scroll down and select Pairing External Bluetooth Devices
- Select Pair located below the Pair iOS/Android Mobile App heading
- From your mobile device, follow the on-screen prompts to connect to the Node.
- Your mobile device is now connected to the BMPRO System.

## MAXX FAN REMOTE CONTROL (IF EQUIPPED)

FAN ON & POWER OFF - Press this button:



FAN ON/OFF

- To start the fan
- To turn the fan off
- To exit Auto Mode

VENT LID POSITION - Press this button to open or close the vent lid



- While the fan is running in Manual Mode press once to close the vent lid and enter “Ceiling Fan” Mode.



## NOTE

This button is not active in Auto Mode. If the fan loses 12volt RV power or power is removed from the fan, use the knob located at the ceiling to manually open or close the vent lid if desired.

# ELECTRICAL

**AIR EXHAUST / INTAKE** - Press this button to reverse the fan from intake or exhaust



## NOTE

In Auto Mode, the fan direction is automatically positioned to Exhaust, but may be overridden and changed to Intake by depressing this key.

**FAN AUTO MODE** - Press this button to enter Auto Mode

- Auto Mode allows the fan lid to automatically open and the fan motor to operate as dictated by the thermostat set point temperature. Once the cabin temperature cools and reaches the set point temperature, the fan lid will close and the fan motor will shut off.
- Pressing this button while in Auto Mode will shut off Auto Mode, close the vent lid and shut off the fan motor.



## THERMOSTAT SET TEMPERATURE

TEMP + ~ Press this button to increase the Set Temperature for Auto Mode.

TEMP - ~ Press this button to decrease the Set Temperature for Auto Mode.



## NOTE

The thermostat temperature range is from 29°F to 99°F or -2°C to 37°C. To change from Fahrenheit to Celsius on the temperature display, press and hold both set temperature keys simultaneously.

## FAN SPEED

Fan Speed + ~ Press this button to increase the fan speed. The fan has ten speeds.

Fan Speed - ~ Press this button to decrease the fan speed. The fan has ten speeds.

NOTE: When the fan speed reaches either the maximum or minimum speed, the fan will respond with 2 quick beep sounds to indicate this.



## LOW BATTERY INDICATOR

- When the battery is at full charge, three black power bars are displayed.
- One or zero power bars displayed indicates the batteries need replacement.



## TRANSMISSION SIGNAL

- This symbol is displayed on the screen when any button is pressed to indicate the signal was transmitted to the fan.
- A beep sound from the ceiling unit indicates the signal from the remote control was received by the fan.

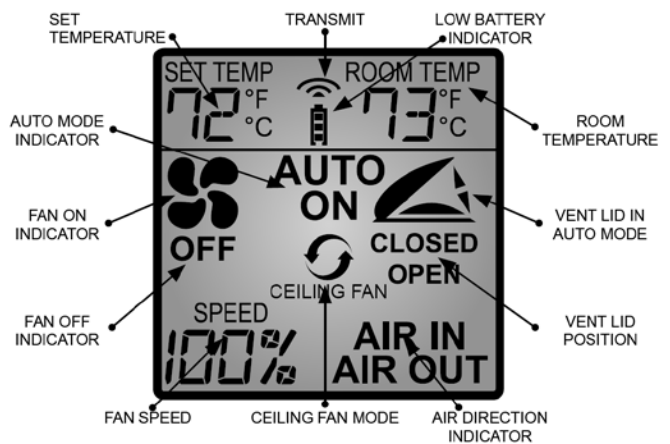

## MAXX FAN DELUXE (IF EQUIPPED)

**CAUTION** (See page 48)

## KNOB, VENT LID OPEN/CLOSE

### Manual Opening Models

Pull to unlock prior to turning. Rotate Knob clockwise to Close Vent Lid; Rotate Knob counter-clockwise to Open Vent Lid. Push "IN" to lock when Vent Lid is open or closed.

### Automatic Opening Models

Allows closing of the vent lid in the event of RV power loss. This knob does not lock. Do not push in or pull out. Rotate knob clockwise to close vent lid; rotate knob counter-clockwise to open vent lid.

Do not use excessive force when operating Knob.

## KEYPAD CONTROLS

Use Keys on Keypad to control MAXXFAN functions (see descriptions on next page).

## INSECT SCREEN RETAINER KNOB

Rotate all 4 knobs 1/2 turn to remove screen.

Caution: Never operate fan with screen removed

## THERMOSTAT TEMPERATURE SENSOR

## CEILING FAN MODE

With the fan motor running, close the Vent Lid to enter Ceiling Fan Mode. The fan motor will continue to run and circulate air within the RV cabin.

## SERIAL NUMBER LABEL

The serial number label is located underneath the round insect screen.

## NOTE

The MAXXFAN is designed to be fully opened or fully closed when the vehicle is moving.

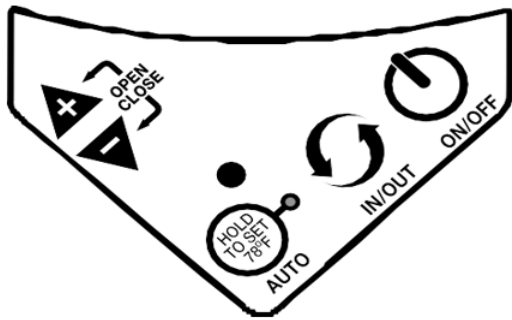

KEYPAD CONTROLS

## KEYPAD CONTROLS

**ON/OFF:** Use this key to start the fan or to turn off the fan. On Automatic Opening Models the lid will also open or close when the fan is turned on or off. On Manual Opening Models pushing this key while in Auto Mode will exit Auto Mode, turn off the fan and the lid will stay in the position you selected. On Automatic Opening Models this button will exit Auto mode, turn the fan off, and close the lid.



ON/OFF

**IN/OUT:** Use this key to reverse the direction of the fan, the fan will slow down and pause for two (2) seconds before resuming operation in the opposite direction. **PLEASE NOTE: THIS KEY HAS BEEN REMOVED ON EXHAUST ONLY MODELS.**



IN/OUT

**AUTO:** Auto Mode allows the thermostat to turn the fan ON and OFF depending on the thermostat setting. Press this key once for less than three (3) seconds to enter Auto Mode, three (3) quick beeps will confirm the MAXXFAN has entered Auto Mode. To EXIT Auto Mode, press the ON/OFF key. Initial factory set point for the thermostat is 78°F/25°C. The green LED will light to indicate the MAXXFAN is in Auto Mode. To adjust, follow instructions below:



AUTO

## NOTE

In Auto Mode the fan direction is automatically positioned to Exhaust, but may be overridden and changed to Intake by depressing this key.

If no previous thermostat temperature was entered, or you wish to change a previous set temperature, press the HOLD TO SET key for more than 3 seconds and you will hear one long beep and the thermostat will be reset to 78°F. To further adjust the set temperature, if desired, use the (+) or (-) Arrow keys to adjust at 1° increments per press. The fan will emit a beeping sound to confirm this setting. If a previous thermostat temperature was entered, the fan will remember this temperature setting and the next time you enter Auto Mode, the fan will start ventilating automatically as directed by the thermostat. The fan speed will automatically adjust based on the cabin temperature. As cabin temperature rises, the fan increases in speed. **Note:** If 12 volt RV power is removed from the MAXXFAN, the thermostat will be reset to 78°F/25°C.

**ARROW - When in Auto Mode:** Use the (+) & (-) Arrow keys to adjust the thermostat set temperature up or down in 1° increments per press.



**When in Manual Mode:** Use the (+) & (-) Arrow keys to adjust the fan speed up or down. When the fan speed reaches either the maximum or minimum speed, the fan will respond with 2 quick beeps to indicate this.

**ARROW KEYS PRESSED TOGETHER:** Automatic Lift Models Only Press the (+) & (-) Arrow keys at the same time to Open or Close the lid. The fan motor will remain in its current state.

## TESTING THE CAMPSITE POWER CONNECTION

**⚠ WARNING ⚠** (See page 48)

**The campsite 120-volt power receptacle(s) should always be tested for proper functionality prior to plugging the recreation vehicle shore power cord into it.**

Campsite 120-volt power receptacles can be tested using a digital multimeter or a dedicated circuit analyzer. Dedicated circuit analyzers plug directly into the campsite power receptacle and minimally test for open neutral, open ground, and correct polarity.

### Connecting The Power Cord

Always test the external power source (i.e., the campsite power receptacle or electrical box) with a ground monitor before connecting your power cord to it. If the ground monitor indicates 'reverse polarity' or an 'open ground' **DO NOT** connect the power cord.

To help prevent power surges from damaging the connected loads, please follow these instructions when hooking up to the external power source:

1. Turn off the load center main 120-volt circuit breaker.
2. Carefully extend the entire length of the power cord (approximately 25'-35') from the electric cable hatch to the external power source.
3. Plug the power cord into the receptacle. Be sure all the power cord prongs are properly plugged into the receptacle.
4. Return to your RV and turn on the load center main circuit breaker.

**The shore power cord should be unplugged when the recreation vehicle is left unattended.**

When you are ready to leave, reverse the power cord connection process. Use care to prevent damaging the power cord electrical connection pins when connecting or disconnecting the shore power cord. Grasp the plug to remove the power cord from the outlet; do not unplug it by pulling on the cord.

### Maintenance

Inspect the power cord for cuts, cracks and worn insulation. Have the power cord replaced immediately if these symptoms are noticed.

## ENERGY MANAGEMENT SYSTEM 30A (IF EQUIPPED)

Key features of the Power Control System include:

- Limits total current to 30 Amps.
- Minimizes circuit breaker tripping.

# ELECTRICAL

- Monitors current draw for the entire RV including loads added by the owner.
- Learns controlled appliance current draw.
- Allows (2) air conditioners to run on 30 Amp service when other appliances are not in use. Panel has built in relays to control (2) air conditioners.

## Operation

This system monitors incoming power and has the ability to turn off a few select loads. It can manage incoming power and avoid tripping the shore circuit breaker.

30A Service would be the normal setting displayed on the digital readout. By pressing the SELECT button you can toggle from 30A to 20A to 15A. When the RV is plugged into a 15 Amp or 20 Amp power supply (i.e. at your home), you would change the display to the 20A or 15A Service setting. The system then attempts to keep the total coach 120VAC current draw under that threshold to prevent tripping your home circuit breaker. It does this by removing power for certain appliances. The status window will illuminate each of the appliances it controls. By using the scroll button you can view the appliances the system controls:

- Water Heater
- Refrigerator
- Rear AC
- Front AC

The device name will display with either SHED or POWERED next to it depending on total amperage available to the coach and whether or not the device is capable of being operated under the existing load. If a device is showing SHED, it has been disabled and cannot be used.

## NOTE

The order of the devices above is referred to as the “shedding” order. If the load exceeds the service amperage on the display, the system goes down this list sequentially and sheds appliances in that order until the system has reduced amperage below the service amperage shown on the display.

For additional information, refer to the manufacturers user guide.

## PROGRESSIVE DYNAMICS INVERTER (IF EQUIPPED)

A factory installed inverter converts 12-volts DC to useable 120-volts AC and supplies AC power to the appliance plugged into it. It is important that you familiarize yourself with the inverter function and operation. The inverter should be “off” when not in use.

## NOTE

The inverter is not intended for use, nor should be used, with any medical device(s). The inverter may, however, be used with some CPAP machines, depending on the CPAP model. Consult your CPAP machine’s instruction manual before use to ensure proper operation.

The inverter has a remote display panel which provide many features:

- Power Button: Press to turn on; hold to turn off
- Select Button: Cycles between display states: Input Voltage, Output Voltage, Output Power, Sleep, Error Code (if applicable)



- Power Indicator: Lights up green when the inverter is on
- Fault Indicator: Flashes red when an error has occurred
- Shore Indicator: Lights up yellow when AC input is detected
- Low Battery Warning Indicator: Lights up red when the battery is nearing the end of its charge
- Sleep: Lights automatically dim after 30 seconds

## Maintenance

There are no customer serviceable parts inside the inverter case and the manufacturer’s warranty will be void if the case has been removed. The inverter cooling fins and the cooling fan should be kept clear of any obstructions.

Refer to the Inverter manufacturers’ manual in your warranty packet for further operating instructions, error codes, changing inverter settings and safety information.

## NOTE

Remote display operates exactly the same as the display mounted to the inverter.

## POWER CONVERTER (IF EQUIPPED)

**⚠ CAUTION ⚠** (See page 48)

The power converter converts 120-volt AC power to useable 12-volt DC power when the shore power cord is connected to an external power source.

The converter has a built-in protective thermal breaker that will shut it down should overheating occur. Overheating can be caused by operating the converter above its maximum power output for an extended period of time, or by an obstruction to its ventilation air flow. To reduce converter heat build keep unnecessary 12-volt lights and motors turned off. Keep the converters cooling fins and fan clear of obstructions.

- **USE ONLY A DEEP CYCLE BATTERY FOR RV USE.** Car batteries (CCA rating) are not designed for RV applications.
- If using multiple batteries they must be the same brand and type. Adding more batteries will provide longer use of DC appliances when not on shore power but may reduce charging efficiency.
- The battery works in conjunction with the converter to supply DC power to the RV. A battery is typically only necessary if you do a lot of dry camping or have slideouts and/or a leveling system.

- Reverse polarity fuse provides protection for the converter when a battery is used. If the battery is connected backwards to the fuse board this fuse would blow preventing damage to the converter.
- Dimming or flickering lights usually indicates an overloaded converter. Remove some of the load by turning off DC lights or appliances.
- Fan is controlled by load. It will begin running at 3 to 6 amp DC draw. It increases in speed with a higher load until 14 to 15 amps. Fan is at maximum speed and stays there even with more load. If load drops below 6 amps DC, the fan shuts off.

Before checking for converter output voltage, the battery cables must be disconnected at the battery. Make sure the converter is plugged into an AC source (105-132 AC volts). Check the converter output voltage at the battery with a voltmeter. Place the voltmeter probes on the disconnected battery cables. If the voltage reads 13.6VDC with no load, the converter is functioning properly.

If the converter output voltage at the battery reads in the 0.0VDC range, or the battery is not charging, check for:

- An open inline fuse in the battery wire
- An open wire between the converter and the RV battery
- Loose ground connection
- Improper torques

If the converter fuses and AC voltage are good, but the converter output still reads zero volts, the converter is not functioning properly.

## Modes of Operation:

**Absorption (Normal) Mode:** 13.6VDC range. Batteries are being charged, just at a slower rate. Converter will not work without AC input.

**Float Trickle Mode:** To get your converter into this mode, reduce the load on the system to almost nothing but the battery. Let the system sit for approximately 44 hours.

Converter voltage will drop to 13.2VDC. If the converter sees any load during this period or after it is in Float Mode it will revert back to Absorption (Normal) Mode. 13.6VDC.

**Bulk Mode:** Converter will not jump into the Bulk Mode unless the battery is below 50% of charge, or approximately below 13.2VDC output voltage. There is no way to force it to go into Bulk Mode.

**Red LED indicates blown fuse.**

## Inspection and maintenance

If the 12-volt power converter is not working (auxiliary battery not being charged) check the reverse polarity fuse(s) located on the end of the converter.

**There are no customer serviceable parts inside the converter case and the manufacturer's warranty will be void if the case has been removed.** If you have further concerns contact your dealer.

**For detailed safety and operating information, refer to the manufacturer's owner's manual.**

## Converter w/Charge Wizard (if so equipped)

Some converters may be equipped with a charge wizard

There are (3) possible charging modes; NORMAL, BOOST and STORAGE. The charge wizard will automatically select the best mode to charge your battery. A green LED next to the wizard mode button will indicate by flashes, which mode is currently being used.



Wizard Button and Reverse Protection Fuses

**Normal Mode:** Green LED flashes once per second; battery is between 50% and 90% charged. Green LED flashes 2-3 times per second; battery is 90% charged. Output voltage is 13.6VDC and the converter is safely completing the charge of the battery.

**Boost Mode:** Green LED is on solid. Output voltage is 14.4VDC to rapidly charge the battery up to 90% of full charge.

**Storage Mode:** Green LED flashes every 6-8 seconds. Output voltage has been reduced to 13.2VDC; the RV battery is fully charged and converter is maintaining the charge.

**Manual Mode (not recommended):** The manual mode button is used to override the charge wizard. Refer to the converter owner's manual for additional information.

**Reverse Battery Protection:** Reverse polarity fuse(s) provide protection for the converter when a battery is used. If the battery is connected backwards to the fuse board a fuse will blow preventing damage to the converter. Four easily accessible fuses are located next to the wizard button. Replace with fuses of the same type and rating.

## 12-VOLT DC SYSTEM

Your motor home lighting is powered by 12-volt electricity. The 12-volt DC system is composed of components that will operate when the following conditions are met:

- The house batteries power all interior and exterior 12-volt components including the lighting fixtures, water pump, 12-volt motors, 12-volt appliances, etc., when the motor home is not connected to a 120-volt power source.
- 12-volt DC power is supplied when the main power switch is 'on'.
- 12-volt power is supplied by the chassis alternator when the chassis engine is running.
- Batteries will be charged as needed when the shore power cord is plugged into an external 120v/240v power source.

## 12-Volt Fuse Panel

**⚠ WARNING ⚠** (See page 48)

The 12-volt fuse panel is labeled to indicate fuse sizes, positions and the components powered. Fuses are located in the load center.

## Replacing a Fuse

Before replacing a fuse, always turn off the electrical components protected by it.

1. Disconnect the shore power cord.
2. Inverter should be OFF.

# ELECTRICAL

3. Remove the fuse panel cover to check fuses.
4. Pull the fuse straight out of the fuse block.
5. Insert a new fuse of the same specified voltage, amperage rating and type in the original location.

The fuse panel label should be kept permanently affixed to your recreation vehicle. Fuses will not offer complete protection of the electrical system in the event of a power surge or spike.

## 12-Volt DC Outlet

**⚠ WARNING ⚠** (See page 47)

There may be one or more 12-volt DC power outlets in your recreation vehicle. When the 12-volt DC outlet is used as a power source for an electric appliance, make sure the appliance operates on 12-volt DC power and that it consumes less than 60 watts (5 amps) of power.

## BATTERIES

**⚠ WARNING ⚠** (See page 47)

### House Batteries

Unless a battery has been fully discharged, house auxiliary batteries are normally charged in one of two ways:

- When the power cord is plugged into 120-volt shore power, or when the generator is operational, the inverter/charger functions as a battery charger and will automatically charge the house batteries when required.
- In certain models, the chassis alternator charges the house auxiliary batteries when the engine is running, provided the chassis batteries are fully charged.

If applicable see the Chassis Guide for information on the chassis batteries and the drivetrain electrical system.

**A fully charged battery** will read 12.65 volts DC with a specific gravity of 1.265 at 80°F (32°C). A battery is considered discharged at 11.89 DC volts or when it has a specific gravity of 1.120 or less. When voltage drops to 11.89 volts, irreversible battery damage can occur.

### Dry Camping

House auxiliary and chassis batteries should be fully charged prior to dry camping. When disconnected from 120-volt shore or generator power (i.e., while dry camping) all electrically operated appliances and accessories must be used sparingly. If equipped, typically a deep cycle battery has an rating of 100, 200, 300, or 400 amp-hours,

During this period these appliances and accessories are being powered by the house auxiliary batteries directly, and/or indirectly through the inverter/charger. If excessive amounts of power are drawn from the house auxiliary batteries, they will become deeply discharged. Permanent battery damage will occur after repeated deep discharge cycles.

### General usage information (using estimated ratings)

12-volt loads drawn from the battery bank(s) while operating 120-volt appliances through the inverter/charger can approach 300 amps on a single inverter/charger equipped motor home, and 700 amps on a dual inverter/charger equipped motor home. Complete battery discharge will occur quickly when inverter/charger loads are applied.

Batteries discharge at a faster rate the deeper they become discharged. To minimize battery discharge:

- When disconnected from 120-volt shore or generator power and not requiring the operation of 120-volt appliances or equipment, turn the inverter OFF.
- If equipped, custom configure your inverter's control panel (see the inverter owner's manual) to best meet your power usage profile.

### Battery Inspection and Care (Lead-Acid, If Equipped)

Check the level of electrolyte in each battery cell once a year.

Add distilled water as needed to reach the split-level marker on each battery. Keep batteries and battery terminals clean and tight.

Check the external condition of the batteries periodically. Look for cracks in the cover and case. Make sure battery vent caps are tight and replace them if they are cracked or broken.

### Battery Inspection and Care (AGM, If Equipped)

Batteries are all sealed AGM types, maintenance free. Check the external condition of the batteries periodically. Look for cracks in the cover and case.

### Battery Storage Instructions

To prevent house auxiliary battery discharge when your motor home will not be connected to shore power for extended periods of time, it is recommended you turn "off" the 12-volt battery disconnect switch, or "main power switch," and disconnect each battery bank at the negative battery cable running to the chassis frame.

During storage, it is important to check battery voltage at least every two weeks and to recharge them as needed to 12.65 volts. If equipped, check the voltage of your batteries at least monthly using the inverter/charger remote control panel. If you remove the batteries from your motor home protect them from accidental shorting and keep them in a cool, dry, well ventilated area.

### Battery Replacement

If house/auxiliary batteries need to be replaced, only deep cycle batteries of the same size and type should be installed.

Do not reverse the positive and negative battery cables. Doing so will blow the reverse polarity fuses that protect the power converter.

### For more information

Contact the battery manufacturer for more information on the house auxiliary batteries. Refer to your Chassis Guide for information pertaining to the chassis batteries.

### 12-Volt Battery Disconnect

The 12-volt battery disconnect or "Main Power" switch is typically located near the entrance door or on the front passenger's console. This momentary switch controls a solenoid which connects or disconnects the house batteries. The indicator light will illuminate Red when turned on.



Disconnect Switch Example

When engaged the battery disconnect solenoid supplies battery power to all accessories connected to the house 12-volt fuse panel. The solenoid must be engaged for the 12-volt house electrical system to operate.

The battery disconnect feature should be used to disconnect the motor home from house battery power during periods of storage or during maintenance.

## NOTE

The combination carbon monoxide/propane alarm requires a constant 12-volt power source. The carbon monoxide/propane alarm remains operational when the battery disconnect solenoid switch, or "main power switch," is in the "OFF" position.

If the Main Power switch is turned OFF, the power entrance door steps will still function when the door is opened.

Depending on your model, your motor home will be equipped with either a Battery Isolator Solenoid or a Battery Isolation Manager.

### Battery Isolator Solenoid (If Equipped)

The isolator solenoid breaks the connection between the house batteries and the chassis battery when the ignition key is in the "OFF" position.

Breaking this connection prevents discharge of the chassis battery (used to start the engine) when using 12-volt devices in the house section of your motor home.

When the engine is running the isolator solenoid engages allowing the house batteries to be charged by the vehicle alternator.

### Auxiliary Start System

Depending on your model, the Battery Boost switch or the Auxiliary Start button engages the solenoid and joins the house battery with the chassis battery to provide a "boost" to help start the motor home if the chassis battery charge is low.

The auxiliary start switch can momentarily connect both the house and chassis batteries should the chassis battery become discharged.

To operate, depress either the "Aux. Start" switch (located on the front driver's dash) or the Battery Boost switch on the driver console and hold it down. While the "Aux. Start" switch or Battery Boost switch is depressed use the ignition key to start the chassis engine. Release the "Aux. Start" switch (or Battery Boost switch) after the engine has started.

### Battery Isolation Manager (If Equipped)

Your motor home may be equipped with a Battery Isolation Manager (BIM) that monitors the battery voltage of both the chassis and house batteries over long periods of time. If it senses a charging voltage it connects the two batteries together. If the charge system is overburdened, it isolates both batteries. When batteries have reached a float charge state for (1) hour, the batteries are isolated to prevent overcharging. It will reconnect if either battery drops to approximately 80% charge and the other is being charged. If batteries are not being charged they will be isolated to prevent an electrical draw in one system from depleting the other battery.

The "Battery Boost" switch is a manual override of the Battery Isolation Manager. It can be used in an emergency (when chassis or house batteries are discharged) to start the chassis engine or the generator.

To operate, press and hold the Battery Boost start switch located on the driver's left side console. While the battery boost switch is pressed, use the ignition key to start the chassis engine or the generator switch to start the generator. Release the battery boost switch once the engine or generator has started.

If your chassis and house batteries are too discharged to start the engine or generator with this method, they need to be recharged with the on-board converter or by connecting the motor home to shore power.

### AUTOMATIC TRANSFER SWITCH (ATS)

Your motor home is equipped with an Automatic Transfer Switch with built in reverse polarity protection. The ATS is microprocessor controlled and will automatically detect which power source is being used (generator or shore power) and allow power from that connection only. You will not have to plug and unplug power to the coach if you decide to run the generator.

If you plug into shore power, the ATS will pass power to the motor home. If the generator is started, it will override the shore power input (called generator dominant) and supply the RV with electrical power from the generator. When the generator is shut down, shore power is restored.

If the RV has 120-volt lights and appliances, there may be a slight flicker of the lights when the ATS changes over from one to the other.

The ATS will disconnect from shore power completely if the power coming in is not high enough quality (i.e. either low/high voltage, or low/high frequency).

When the generator is operating, it powers the inverter/charger which in turn functions as a multi-stage battery charger to charge the house auxiliary and chassis batteries.

## NOTE

The generator requires 12-volt power from the house auxiliary batteries to start, and draws fuel to operate from the chassis fuel tank. If the fuel level in the chassis fuel tank drops to or below ¼ full, the generator will shut "off" and cannot be re-started until the fuel tank is filled to above ¼ full. Use the prime function to clear air from the fuel lines.

Refer to and follow safety information found in the manufacturer's troubleshooting guide found in your warranty packet.

# ELECTRICAL

## LOAD CENTER

The Load Center contains 12VDC fuses and 120VAC circuit breakers for almost all of the electrical appliances and circuits in the RV. The 120V main breaker may be located in this panel and will turn off all 120-volt power to the RV. Load center location, appearance and configuration may vary by model. Refer to the diagram inside the load center for specific fuse assignments.

Motor homes may have separate small panels for breakers and fuses. They are normally located in close proximity to each other typically in the bed platform. The converter is mounted separately, typically under the bed platform.

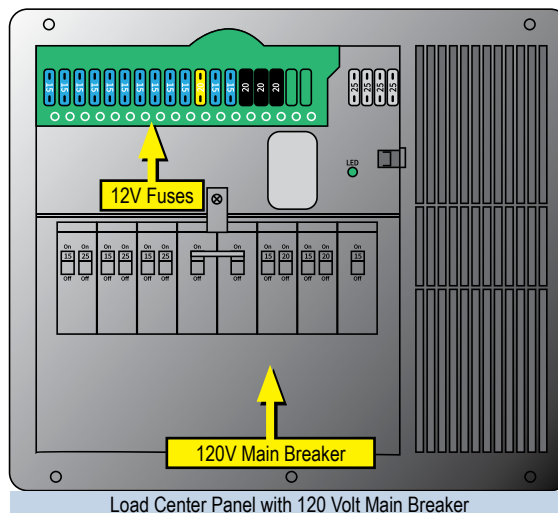
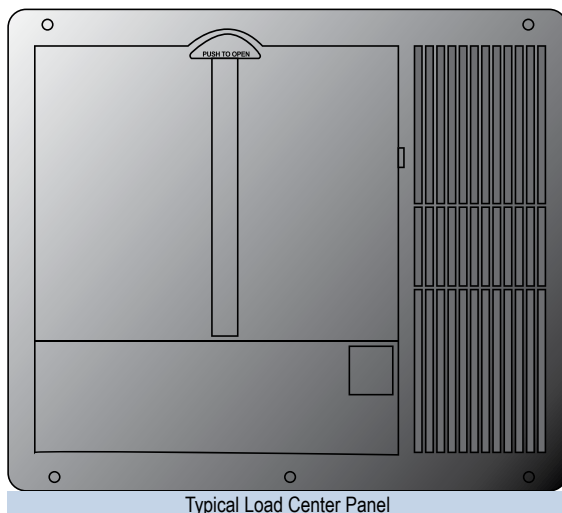

## APPROXIMATE ELECTRICAL LOAD RATINGS

12 VOLT SYSTEM	
Exterior Entertainment Center	5-7 AMPS
Fan	1.5 AMPS
Furnace	12.0 AMPS
Generator Start	95.0 AMPS*
Illuminated Switch	.125 AMP
Inverter	variable
Leveling System	95.0 AMPS*
LP Detector	.125 AMP
Light; LED	1.7 AMPS
Light; Vanity	4.2 AMPS
Lights; Aisle	1.0 AMP
Lights; Baggage Compartment / Shower	1.4 AMPS
Lights; Decorative Wall / Map / Porch	1.5 AMPS
Lights; Double -12"	2.0 AMPS
Lights; Double -18"	2.5 AMPS
Power Awning	10.0 AMPS*
Power Vent	5.0 AMPS
Refrigerator (if 12V Refrigerator is equipped)	3.0 AMPS
Step Cover	10.0 AMPS*
TV Plate/Antenna Booster	1.0 AMP
Water Heater	6.0 AMPS
Water Pump	7.0 AMPS

\*Momentary Load

12 Volts: Labeled watts divided by 12 = Power consumed in AMPS

120 VOLT SYSTEM	
Air Conditioner	18 AMPS
Coffee Maker	6-12 AMPS
Converter (each)	8 AMPS
DVD System	3 AMPS
Fireplace	15 AMPS
Hair Dryer or Curling Iron	10-14 AMPS
Microwave	15 AMPS
Refrigerator	6 AMPS
Satellite Receiver	2 AMPS
TV	2-4 AMPS
Vacuum Cleaner	8 AMPS
Washer/Dryer	12 AMPS
Water Heater	12 AMPS

\*Momentary Load

120 Volts: Labeled watts divided by 120 = Power consumed in AMPS

## 120-VOLT CIRCUIT BREAKERS

**⚠ CAUTION ⚠** (See page 48)

The 120-volt AC circuit breakers located inside the load center protect all 120-volt wiring and components from circuit overloads and short circuits. Should a circuit overload or short circuit occur the circuit breaker protecting the affected circuit will “trip” preventing the flow of electricity through that circuit.

If a circuit breaker trips, shut off the appliance on that circuit (i.e., power converter, etc.) and allow the circuit breaker to cool down for a brief period of time. After it cools down, reset the circuit breaker by moving its lever “off” and then back to the “on” position. If the circuit breaker re-trips or frequently trips, contact your dealer to have the electrical problem diagnosed and repaired.

A circuit breaker identification label is permanently attached to the inside surface of the 120-volt Load Center.

### Replacement

**⚠ WARNING ⚠** (See page 47)

Only replace circuit breakers with those of the same specified type, voltage, and current rating. **Never replace a circuit breaker with one listed at a higher amperage rating.** Please contact your dealer for repair assistance when replacing circuit breakers.

### Maintenance

At the beginning of the camping season, inspect the circuit breakers and replace as needed. Test by turning each circuit breaker “off” and back “on”. Circuit breakers are wearable parts and must be replaced as needed as part of your RV maintenance. If you have any questions, contact your dealer.

A label is provided to explain the function of every 120-volt circuit breaker. This label is located on or near the appropriate load center or sub-panel and must remain permanently affixed to the recreation vehicle.

## 120-VOLT, 30-AMP AC ELECTRIC SYSTEM

**⚠ WARNING ⚠** (See page 47)

The 30-amp 120-volt 60hz AC electrical system is designed to operate on 1 leg of 120-volt power at a maximum current flow of 30-amperes.

Exposure to voltages higher or lower than a nominal 120-volts will damage or shorten the service life of the electrical system and appliances. The 30-amp 120-volt 60hz AC electrical system can be powered by the 120-volt 60hz utilities found in campgrounds or by 120-volt 60hz generator power.

The following electrical components will only operate when your recreation vehicle is connected to shore or generator power: 120 to 12-volt power converter, air conditioner, refrigerator, microwave oven, television(s), home theater system(s), electric water heater, washer, dryer, fireplace, and appliances plugged into convenience receptacles.

### 30-amp Power Cord

**⚠ WARNING ⚠** (See page 47)

The 30-amp external utility power cord is commonly referred to as the “shore” power cord. It is designed to mate and properly function with 30-amp “shore” power receptacles available at most campgrounds.

The shore power cord is designed to continuously carry the 30-amp current flow required to power each leg of the electrical system. It also creates a critical ground connection between the vehicle electrical system and the campground shore power receptacle.

Always test the external power source (i.e., the campsite power receptacle or electrical box) with a ground monitor before connecting your power cord to it. If the ground monitor indicates ‘reverse polarity’ or an ‘open ground’ **DO NOT** connect the power cord.

Regularly inspect the shore power cord for cuts, cracks, worn insulation and other damage. Have the power cord replaced immediately if problems exist.

### Calculating 30-amp Electrical Load

When connecting appliances to the electrical system, 120-volt power usage is limited to a total of 30-amps. Operating appliances collectively places an added load on your 120-volt electrical system.

A circuit breaker “trip” may occur if you overload the recreation vehicle and/or campground electrical system. The amperage rating of individual appliances can be calculated by dividing appliance wattage consumed (normally listed on the appliance) by nominal design voltage (120 for a 120-volt appliance). For example: 1200 watts divided by 120-volts equals 10 amps.

## GENERATOR

**⚠ WARNING ⚠** **⚠ CAUTION ⚠** (See page 47) & (See page 48)

Your motor home is equipped with an LP or a fuel powered generator. The generator produces 120/240-volt power compatible with the motor home electrical system. It can power the entire motor home when 120/240-volt shore power is not available.

### Before Starting the Generator

1. Make sure the carbon monoxide detector is working.
2. Turn off air conditioners and all other 120-volt appliances.
3. Check for fuel, exhaust and coolant leaks.

**STOP the generator immediately if there is a fuel, exhaust or coolant leak. Have all leaks repaired prior to placing the generator back in service.**

### Transfer switch

For more information, see the Automatic Transfer Switch (ATS) section.

## NOTE

The diesel (or gas) generator requires 12-volt power from the house auxiliary batteries to start, and draws diesel fuel (or gas) to operate from the chassis fuel tank. If the fuel level in the chassis fuel tank drops to or below 1/4 full, the generator will shut off and cannot be re-started until the fuel tank is filled to above 1/4 full.

### Maintenance

During periods of extended storage:

1. Add a diesel fuel additive to the chassis fuel tank to prevent algae growth (only with a diesel fueled generator).
2. Completely fill the chassis diesel fuel tank to prevent water condensation and rust in the tank (only with a diesel fueled generator).

## ELECTRICAL

- Cover the end of the generator exhaust pipe with screen to prevent bug and rodent intrusion.

With the exception of simple items, such as normal maintenance (i.e., oil changes, etc.), all service work should be done by an authorized repair facility. Improper adjustments can damage the generator and electrical appliances and can result in a safety hazard. **Follow the generator owner's manual for maintenance intervals and recommendations.**

**Exercising Your Generator** – When storing the generator for extended periods of time, it is important to run the generator regularly to keep it in good working order. Lack of exercise can cause moisture build-up in the fuel system resulting in poor performance.

For more information on generator operation and maintenance, refer to the generator owner's manual.

### STARTING THE GENERATOR

Your motor home has a touchscreen to control the generator and Your motor home has a manual switches located either in the door area, the Command Center panel, on the dash, or in an overhead cabinet. The generator may also be controlled via the touch screen (if equipped). There is a secondary switch located on the generator itself. An hour meter that keeps track of generator hours used is located on the touchscreen and a separate hour meter on the generator.

#### To Manually Start the Generator

- At either "START/STOP" switch, press and hold the start portion of the switch to start the generator. Depending on the outside temperature the start process can take up to 15 seconds. Once the generator starts running, release the switch.
- An LED above the start switch will light when the generator is running.
- For better performance and engine life, especially in colder weather, let the generator engine warm up for two minutes before turning "ON" 120-volt appliances.

For more information on generator operation and maintenance, refer to the manufacturer's owner's manual.

#### Touchscreen - Automatic Generator Start (AGS)

Your motor home model may be equipped with an Automatic Generator Start system (AGS). The controls are built into the touchscreen system. When enabled, the Automatic Generator Start system will automatically start and stop the generator according to operator or factory pre-selected parameters.



Refer to the AGS Start section or the Touch Screen User Guide (in your warranty packet) will give detailed instructions on the Automatic Generator Start.

### SOLAR PREP (IF EQUIPPED)

**CAUTION** (See page 48)

Your motor home may be equipped with a roof mount solar panel quick connection. This allows a (customer purchased) solar panel to be installed permanently on the roof. Installation will consist of the solar panel(s), regulator and wiring/fusing between the regulator and batteries. There are no other solar plugs for portable solar panels on the vehicle.

The (black ABS) solar prep box is located in a basement compartment of the RV and is marked with a solar prep label (indicating wire colors and polarity). There is also an additional label indicating the RV is wired for solar.



Roof Mount

When connected, the solar panel will supply power to the battery and the battery will supply power to all the 12V systems as needed.

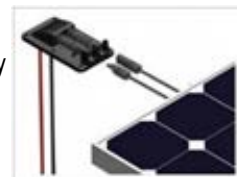

### SOLAR PANEL (IF EQUIPPED)

Solar panels produce 12-volt DC electricity when exposed to sunlight. Energy produced by the solar panels is used to charge the house auxiliary and chassis batteries.

#### Controller

The controller is capable of charging two battery banks – house and chassis. A status LED indicates connectivity of batteries.

Refer to the manufacturer's operation manual in your warranty packet for more detailed information.

#### Maintenance

Clean the solar panel upper surface regularly using a soft cloth or sponge with water and a mild detergent. Do not use harsh chemicals or abrasive brushes that might damage the panels' upper translucent surface.

**For additional information, refer to the manufacturer's manuals for the controller and monitor.**



### **GENERATOR (See page 45)**

**CARBON MONOXIDE IS DEADLY!** Do not run the generator when your motor home is indoors or in a confined space.

**DO NOT** use the AGS AUTO ON or QUIET ON modes (if so equipped) when your motor home is indoors or in a confined space.

Asphyxiation or carbon monoxide poisoning hazards exist whenever generator exhaust gasses can accumulate.

**MOVING PARTS AND ELECTRICITY** can cause severe personal injury or death. To reduce exposure to these hazards, **always disable AGS (if so equipped) before:**

- Sleeping in vehicle, unless vehicle has a working CARBON MONOXIDE detector.
- Parking vehicle in garage or confined space.
- Parking vehicle for storage.
- Servicing generator.
- Servicing batteries.
- Servicing appliances or electrical systems.
- Fueling the vehicle.

### **BATTERIES ((See page 42))**

- **Do not store anything inside the battery compartment(s)** or near the batteries that could touch the battery or battery cable terminals. Contact with the battery or battery cable terminals could cause an electrical short circuit, discharge the batteries, or start an electrical fire.
- **Keep sparks, cigarettes and flames away from the batteries as the hydrogen gas they create may explode.** Do not connect a booster battery or other power source that outputs more than 14.2-volts DC to the RV batteries. Use adequate ventilation when charging or using batteries in an enclosed space.
- Remove metal jewelry and always wear eye protection when working around batteries.
- **Do not allow battery electrolyte (acid) to come into contact with skin, eyes, fabric or painted surfaces.** Electrolyte is a sulfuric acid solution that could cause serious personal injury or property damage. If your hands, eyes, clothes or the painted surface of your RV are exposed to electrolyte, flush the exposed area thoroughly with water. If electrolyte gets in your eyes, immediately flush them thoroughly with water and get prompt medical attention.
- **Make sure the inverter/charger is turned “off” before disconnecting the negative battery cable from the battery bank.** Keep the batteries out of the reach of children.

### **30 AMP POWER CORD (See page 45)**

- Do not hook up the power cord to any receptacle until you have verified proper polarity and grounding. Polarity indicators can be purchased in most electrical and hardware stores.
- Do not use any cheater plug, adapter or extension cord to reconfigure incoming AC power or break the continuity of the circuit connected to the grounding pin.
- Do not connect the power cord into an outlet that is not grounded, or adapt the power cord plug to connect it to a receptacle for which it is not designed.
- Do not remove the grounding pin to connect to a non-grounded receptacle. Removal of the ground pin disables an important safety feature designed to prevent shock and electrocution hazards.
- Do not connect the power cord to an extension cord. Use of an improper extension cord will cause overheating of the cord as well as potentially causing premature failure of the AC equipment.

It is the responsibility of the owner of the electrical receptacle to ensure that the receptacle is properly wired and grounded. Reverse polarity and/or improper grounding of your recreation vehicle can cause personal injury or death.

### **REPLACEMENT - CIRCUIT BREAKER (See page 45)**

Replacement circuit breakers must be of the same voltage, amperage rating and type. Never use a higher rated replacement circuit breaker; doing so may cause a fire by overheating the RV wiring.

### **120-VOLT 30 AMP AC ELECTRIC (See page 45)**

- Make certain the external power source you connect the power cord to is a properly wired **30-amp NEMA TT-30** RV receptacle and not 240-volt AC. **PLUG INTO 30-AMP SERVICE ONLY.**
- Circuit breakers and fuses will not offer complete protection of the electrical system in the event of power surge or voltage spike.

### **12-VOLT DC OUTLET (See page 42)**

Keep the protective dust cap on the 12-volt DC outlet when not in use to prevent intrusion of foreign material and potential short circuit conditions.

**TESTING CAMPSITE POWER (See page 39)**

**Do not hook the power cord to any receptacle until you have verified proper polarity and grounding.**

**DO NOT** plug the shore power cord into a campsite receptacle(s):

- That has reverse polarity
- That has non-functioning ground circuits
- That shows outward signs of heat damage.

**Doing so may result in property damage or serious injury.** Plugging the shore power cord into an incorrectly wired power source could damage the recreation vehicle electrical system and result in severe or fatal injury. Damage or injury resulting from connection to malfunctioning or improperly wired power sources is not covered by your recreation vehicle warranty.

**DO NOT**

- Do not use any cheater plug, adapter or extension cord to reconfigure incoming AC power or break the continuity of the circuit connected to the grounding pin.
- Do not connect the power cord into an outlet that is not grounded, or adapt the power cord plug to connect it to a receptacle for which it is not designed.
- Do not remove the grounding pin to connect to a non-grounded receptacle. Removal of the ground pin disables an important safety feature designed to prevent shock and electrocution hazards.
- Do not connect the power cord to an extension cord. Use of an improper extension cord will cause overheating of the cord as well as potentially causing premature failure of the AC equipment.
- The power cord must be fully extended when in use and not left coiled in the electrical compartment or on the ground. A power cord left coiled may potentially create enough heat to melt its protective casing.

It is the responsibility of the owner of the electrical receptacle to ensure that the receptacle is properly wired and grounded. **Reverse polarity and/or improper grounding of your RV can cause property damage or serious personal injury.**

**ELECTRICAL SYTEM (See page 35)**

Use caution when using metal tools. If a tool contacts a battery terminal or metal connected to it, a short circuit could occur which could cause personal injury, explosion or fire.

**12-VOLT FUSE PANEL (See page 41)**

Replacement fuses must be of the same voltage, amperage rating and type. **Never use a higher rated replacement fuse;** doing so may cause a fire by overheating the RV wiring.

**120-VOLT CIRCUIT BREAKERS (See page 45)**

Circuit breakers and fuses will not offer complete protection of the electrical system in the event of power surge or voltage spike.

**SOLAR PREP ((See page 46)**

Adding additional solar panels or equipment will affect the carrying capacity of the motor home. Vehicle weight ratings should be considered before adding these components.

**GENERATOR (See page 45)**

Excessive usage can overheat and damage the generator starter motor. Do not engage the starter motor for more than 20 seconds at a time. If the generator does not start after the first attempt, wait at least two minutes before beginning another start sequence. If the generator does not start after a third attempt, refer to the generator owner's manual for additional information.

**POWER CONVERTER (See page 40)**

It is important that the fluid level of any connected batteries be checked on a regular basis. All batteries will "gas" and lose some fluid when continuously connected to any charging source (does not apply to "gel-cell" batteries).

**MAXX FAN DELUXE (See page 48)**

When removing screen for cleaning, turn the MAXXFAN OFF and remove the vehicle 12 volt power to the MAXXFAN. When cleaning your MAXXFAN, use only a mild detergent solution.

# SECTION 7: FUEL & PROPANE SYSTEM



## EXHAUST GAS FUMES

**⚠ WARNING ⚠** (See page 53)

To avoid breathing exhaust gases, follow these precautions:

- Do not run the engine in confined areas, such as a closed garage, any longer than needed to move your motor home in or out of the area.
- Windows should be closed while driving or running the generator (if so equipped) to avoid drawing dangerous exhaust gases into the motor home.
- If you suspect that exhaust fumes are entering the passenger compartment, have the cause determined and corrected as soon as possible.

If you must drive under these circumstances, close all the windows, and adjust the heating or cooling system to force outside air into the motor home (set the blower on high speed).

The best protection against carbon monoxide entry into the motor home is a properly maintained ventilation system and an active carbon monoxide detector. To allow for proper operation of the motor home ventilation system, keep the ventilation inlet grill(s) clear of snow, leaves or other obstructions at all times.

### Maintenance

It is recommended that the exhaust system and vehicle body be inspected by a qualified motor home service center:

- Each time the engine is ready for an oil change.
- Whenever a change in the sound of the exhaust is noticed.
- Whenever the exhaust system, underbody or rear of the vehicle is damaged.

For more information refer to your Chassis Guide.

## FUEL SAFETY

**⚠ DANGER ⚠** (See page 52)

### Fuel Selection

Some generators are fueled by the same system used to fuel the chassis engine. Check the generator manufacturer and the chassis manufacturer information to help determine the type of fuel best suited for this dual application.

### Fuel Fill Cap

**⚠ WARNING ⚠** (See page 53)

Remove the fuel fill cap by slowly turning it counterclockwise, waiting for any “hiss” noise to stop, and then unscrew the cap all the way. To close the fuel fill cap, securely turn the cap clockwise until you hear clicking sounds.

### Filling The Fuel Tank

**⚠ DANGER ⚠** (See page 53)

Use care when fueling your motor home. If you spill fuel on the motor home, clean it up immediately. Fuel can dull or soften paint and damage other surfaces.

## PROPANE GAS SYSTEM (IF EQUIPPED)

**⚠ WARNING ⚠** (See page 53)

Propane or LP (liquefied petroleum) gas is an efficient form of energy when proper handling and safety precautions are observed. The propane system in your motor home furnishes the fuel for cooking, heating, hot water and can be an alternative energy source for refrigeration. Propane is heavier than air and tends to flow to lower areas and will sometimes pocket in these low areas, such as the floor. Your motor home is equipped with a propane alarm (refer to *Safety*

# FUEL & PROPANE SYSTEM

*Precautions, Combination Carbon Monoxide (CO)/Propane Alarm.*

The propane fuel system is comprised of numerous components such as the propane container, hoses, propane gas regulator, piping and copper tubing to each appliance.

Your motor home has been carefully tested at the factory and by your selling dealer for leakage. Travel vibrations can loosen fittings. Have the vehicle propane system checked at all connections soon after the purchase of your vehicle, and after the initial filling of the propane tanks.

Continued periodic checks of the propane system at 5,000 miles of travel (or at least once a year) by a qualified propane service representative as part of your normal maintenance is recommended. Hand tighten the LP gas system valves only, do not use a wrench or pliers as over tightening may damage the valve seals and cause them to leak.

## NOTE

All propane lines have been checked with air pressure at the time of manufacture. Dealers are required to recheck and adjust pressure before retail delivery.

The following label should be kept permanently affixed to the motor home:

**! DANGER**

ALL PILOT LIGHTS, APPLIANCES, AND THEIR IGNITORS (SEE OPERATING INSTRUCTIONS) SHALL BE TURNED OFF BEFORE REFUELING OF MOTOR FUEL TANKS AND/ OR PROPANE CONTAINERS.  
FAILURE TO COMPLY COULD RESULT IN DEATH OR SERIOUS INJURY.

**! WARNING**

DO NOT FILL PROPANE CONTAINER(S) TO MORE THAN 80 PERCENT OF CAPACITY.  
FAILURE TO COMPLY COULD RESULT IN DEATH OR SERIOUS INJURY.

**! CAUTION**

THIS PIPING SYSTEM IS DESIGNED FOR USE WITH PROPANE ONLY. DO NOT CONNECT NATURAL GAS TO THIS SYSTEM.

Securely cap this inlet when not connected for use. After turning on propane, except after normal cylinder replacement, test propane piping and connection to appliances for leakage with soapy water or bubble solution. Do not use products that contain ammonia or chorine. DD-37

Propane Label

## Propane Gas Container

Propane is a true gas compressed into a liquid form. As the fuel is released from the container, it changes to vapor which is then used for the operation of the appliances. Propane will not run through the appliances in the liquid state.



ASME tank

A permanently mounted A.S.M.E. approved propane container is located under the floor of the motor home.

## NOTE

Tanks are to be installed, fueled and maintained in accordance to State and Local codes, rules, regulations or laws.

Propane expands 1½ percent for every ten degrees of increase in temperature. It is imperative to leave sufficient space inside the container to allow for natural expansion of gas during warmer weather.

## Servicing or Filling

**! WARNING !** (See page 53)

Because the container is not removable, the motor home will need to be driven to a qualified propane facility for servicing or filling.

Only the authorized gas service technician(s) should be near the motor home while the propane tank is being filled. The new propane container must be carefully purged for proper appliance performance and operation. The propane tank must NEVER BE OVERFILLED.

Replace all protective covers and caps on the propane system and/ or container after filling. Make sure the valve is closed and the compartment door is securely latched.

## LP Gas Container Overfill

Never allow your propane tank to be filled above the maximum safe level as indicated by the fixed liquid level gauge.

Do not allow the visible gauge to be used for filling. Overfilling the propane container above the liquid capacity indicated on the container, could allow liquid propane to enter the system that is designed for vapor only creating a hazardous condition.

The following warning label has been placed by the propane container.

**! WARNING**

DO NOT FILL CONTAINER(S) TO MORE THAN 80 PERCENT OF CAPACITY. FAILURE TO COMPLY COULD RESULT IN DEATH OR SERIOUS INJURY. OVERFILLING THE PROPANE CONTAINER CAN RESULT IN UNCONTROLLED PROPANE FLOW, WHICH CAN CAUSE FIRE OR EXPLOSION. A PROPERLY FILLED CONTAINER CONTAINS APPROXIMATELY 80 PERCENT OF ITS VOLUME AS LIQUID PROPANE.

Propane System Label

Refer to your Warranty Packet for more information on the LP gas system components.

## Propane Regulator

## NOTE

Regulator appearance and type may vary by model.

### Single stage regulator

Some models are equipped with a single stage regulator.

### Two stage regulator

The two-stage regulator has the only moving components in the propane system. Its sole function is to reduce the pressure from the propane containers to a safe and consistent low operating pressure. The first stage reduces the container pressure to 10-13 lbs. The second stage reduces the 10-13 lbs. of pressure further to

an operating pressure of 11" W.C. (water column) or 6.35 oz. of outlet pressure to your appliances.

The second stage is adjustable and will need to be adjusted by your dealer or qualified propane service technician for optimum performance (this adjustment should always be made with a properly calibrated manometer).

If the pressure is too high, it affects performance and safety; if the pressure is too low, your appliances will not operate correctly.

If your recreation vehicle is equipped with the "automatic" two-stage regulator, with both cylinders full of propane, turn the lever on the regulator towards the cylinder you wish to use first. This will be the "supply" cylinder and the other the "reserve". Slowly open both cylinder valves. The indicator on top of the regulator will turn bright green. When the cylinder becomes empty, the indicator will change to bright orange. Turn the regulator lever to the side of the "reserve" cylinder and the green signal should return. You may now remove the empty cylinder to have it refilled without interrupting the flow from the full bottle. After filling the cylinder, connect the pigtail hose and slowly open the bottle valve.

Refer to the manufacturer's pamphlet included in your warranty packet and follow all safety instructions and warnings listed.

## Propane Gas Container (If Equipped)

**⚠ WARNING ⚠** (See page 53)

DOT propane cylinders used on RVs must be removed for filling and filled by weight at a qualified propane facility. Equipped with an overfill protection device (OPD), they must be oriented correctly, with markings indicating the top position. After filling, securely reinstall the cylinders, close the service valve, and use a dust cap or plug for transportation or storage.

Propane, compressed into a liquid, vaporizes when released for appliance use. It expands with temperature increase, requiring space inside the container for expansion during warmer weather. Keep the main shut-off valve closed except during system use or cylinder filling. Hand-tighten the valve to avoid damaging the interior seals. Leaks should be checked after initial filling and periodically thereafter. When filling a new cylinder, ensure it's purged of trapped air to enable proper appliance ignition.

## PROPANE USE AND SAFETY (IF EQUIPPED)

Propane is a colorless and odorless gas that, in the liquefied state, resembles water. An odorant (usually a sulfur compound) is added as a warning agent. If you smell propane within the vehicle, quickly and carefully perform the procedure listed on the propane system label. This label has been placed in the vehicle near the range for models equipped with a propane system.

When a propane container is low, there may be a concentration of an

onion or garlic-like odor, which can be mistaken for a propane gas leak. After the propane container has been refueled, the odor will usually disappear. If not, turn off the valve(s) and have the propane system inspected by your dealer or qualified propane service representative.

## Propane Leak Test

**⚠ DANGER ⚠** (See page 52)

Leaks may be found easily with a soapy water solution. Do not use a solution containing ammonia or chlorine when locating leaks. These products are corrosive to copper gas lines and brass fittings, which could result in deterioration of the copper and brass components. Apply the soapy solution to the outside of the gas piping fittings. If a leak is present, the soapy solution will "bubble" at the leak point. If a leak is indicated, shut off the propane system valve(s) and contact your dealer or qualified propane service representative immediately.

## Using the Propane System

Use the following steps for propane operation:

1. Close ALL burner valves, controls and pilot light valves.
2. Open the main valve in the propane tank slowly to avoid a rush of propane vapor through the excess flow valve, causing propane "freeze-up." Should you experience propane "freeze-up", close the main valve and wait 15 minutes before trying again.
3. Listen carefully as propane begins to flow. If a hissing noise is heard for more than one or two seconds, close the main valve and contact your dealer to have the propane system tested.
4. Light the appliances as needed and directed in the appliance manufacturer's owner manual located in the Warranty Packet.

Keep the propane container valves closed at all times unless you are using the propane gas system or are having the propane container filled.

## Make sure that you read and fully understand ALL safety requirements for handling and operation of the propane system.

The propane system must be handled with care. If you have any questions or concerns, consult with your dealer and/or the specific appliance manufacturer.

If you have double cylinders on your recreation vehicle, use only one at a time. Otherwise, the propane supply will be drawn equally from both cylinders until the supply has been totally exhausted. Using one cylinder until it is empty and then using the second cylinder will allow you to fill the empty cylinder at your convenience without running out of propane.

### ⚠ DANGER

IF YOU SMELL PROPANE

1. Extinguish any open flames, pilot lights and all smoking materials.
2. Shut off the propane supply at the container valve(s) or propane supply connection.
3. Do not touch electrical switches.
4. Open doors and other ventilating openings.
5. Leave the area until odor clears.
6. Have the propane system checked and leakage source corrected before using again.

Ignition of flammable vapors could lead to a fire or explosion and result death of serious injury.

Propane System Label



## FUEL & PROPANE SYSTEM

### Cooking With Propane Gas

**⚠ WARNING ⚠** (See page 53)

Unlike homes, the amount of oxygen supply is limited due to the size of the recreation vehicle. Proper ventilation when using the cooking appliance(s) will help avoid the danger of asphyxiation.

It is especially important that cooking appliances not be used for comfort heating, as the danger of asphyxiation is greater when the appliance is used for long periods of time. **FAILURE TO COMPLY MAY RESULT IN DEATH OR SERIOUS INJURY.**

These warning labels are located in the cooking area to remind the user to provide an adequate supply of fresh air for combustion.

**⚠ DANGER**

Do not use gas cooking appliances for comfort heating. Can lead to carbon monoxide poisoning, which can lead to death or serious injury.

**⚠ WARNING**

Gas cooking appliances need fresh air for safe operation. Before operating:  
Open vents or windows slightly or turn on exhaust fans prior to using cooking appliance. Gas flames consume oxygen, which should be replaced to ensure proper combustion. Improper use can result in death or serious injury.

Cooking / Comfort Heating Label

**TO ENSURE A SUPPLY OF FRESH AIR TO OCCUPANTS, OPEN VENTILATORS WHEN FUEL BURNING RANGE, FUEL BURNING CARRY-ON APPLIANCE, AND/OR FUEL BURNING LIGHTS ARE IN OPERATION. COOKING APPLIANCES SHOULD NOT BE USED FOR SPACE HEATING PURPOSES.**

**DE MANIÈRE À ASSURER UNE ALIMENTATION EN AIR FRAIS AUX OCCUPANTS, OUVRIR LES VENTILATEURS LORSQUE LA CUISINIÈRE, LES APPAREILS DE CHAUFFAGE PORTABLES ET/OU LES LAMPES DE COMBUSTION D'HUILE SONT EN FONCTIONNEMENT. LES APPAREILS DE CUISSON NE DOIVENT PAS SERVIR AU CHAUFFAGE DES LOCAUX.**

JA-110

Ensure a Supply of Fresh Air Label (Canada Units Only)

### Calculating Propane Gas Usage

Most RV gas appliances are operated intermittently, and each has a different BTU rating. You will need to consider this when planning your propane supply and consumption. Unless there is heavy use of hot water, the water heater consumption of propane is minimal. During cool temperature or high wind conditions, furnace consumption can be extremely high.

To calculate your propane supply, take the BTU ratings for your propane appliances and divide that into the BTU availability. Each gallon of propane gas (3.785 liters) produces about 91,500 BTU's (96,528 kilojoules) of heat energy.

### Propane Consumption Chart

The following chart provides average propane consumption information.

Appliance	Average BTU Consumption per Hour	Kilojoules/Hour
Water Heater	8,800	9,280
Refrigerator	1,200 – 1,500	1,270 – 1,580
Furnace	35,000 – 40,000	36,930 – 42,200
Range/oven	7,100	7,490
Range, rear burner	6,500	6,860
Range, front burner	9,000	9,490
Outside Grill	10,000	10,550

### Traveling with Propane

**⚠ DANGER ⚠** (See page 53)

## NOTE

Some states prohibit propane appliance operation during travel, especially in underground tunnels. Know the laws for the areas where you travel.

Use care when fueling your motor fuel tanks and/or propane containers. Ensure your propane tank is properly fastened in place.



## FUEL & PROPANE SYSTEM DANGER

### FUEL SAFETY ((See page 49)

Automotive fuels can cause serious injury or death if misused or mishandled. If you have further questions, consult your dealer or Customer Service for assistance.

- Always shut OFF the vehicle engine while refueling.
- Do not bring or store fuel or other flammable liquids inside the motor home as a fire or explosion may result.
- Before refueling, extinguish all smoking materials and any open flames.
- Before refueling, always turn OFF all spark producing appliances (i.e., water heaters, furnaces, etc.).
- Do not overfill the fuel tank(s). The pressure in an overfilled fuel tank may cause leakage and lead to fuel spray and/or fire.
- Fuel spills represent a serious fire hazard, and should be cleaned up immediately.
- Never restart an engine or re-light any pilot lights while raw fuel is present.

**FAILURE TO COMPLY COULD RESULT IN FIRE, DEATH OR SERIOUS INJURY.**

### PROPANE LEAK TEST (See page 51)

**Never use an open flame to test for a propane leak.** Do not check for leaks using products that contain ammonia or chlorine as these products can cause cracks to form on the metal tubing and brass fittings.



**FILLING THE FUEL TANK (See page 49)**  
**TRAVELING WITH PROPANE (See page 52)**

All pilot lights, appliances and their igniters (see operating instructions) should be turned off before refueling of motor fuel tanks. These can cause ignition of flammable vapors, which can lead to a fire or explosion.

**FAILURE TO COMPLY COULD RESULT IN FIRE, DEATH OR SERIOUS INJURY.**



### FUEL & PROPANE SYSTEM WARNING

**EXHAUST GAS FUMES (See page 49)**

- Avoid inhaling exhaust gases as they contain carbon monoxide, which is a potentially toxic gas that is colorless and odorless.
- If you are in a parked motor home with either the engine running or a generator running there is a potential for exhaust fumes to filter back into the motor home.

**FUEL FILL CAP (See page 49)**

Do not replace the fuel fill cap with one of a different type. Only use a cap specified for your motor home. Use of a substitute cap may create excessive fuel system pressure, resulting in fuel station damage and improper operation in a collision.

**COOKING WITH PROPANE GAS (See page 52)**

- Do not turn gas range burner controls to ON and allow gas to escape before lighting.
- Do not use portable fuel burning equipment (i.e., wood and charcoal grills or stoves) inside the recreation vehicle.

**PROPANE GAS SYSTEM (See page 49)**

Propane cylinders should not be placed or stored inside the vehicle. LP-gas cylinders are equipped with safety devices that relieve pressure by discharging gas into the atmosphere.

**SERVICING OR FILLING (See page 50)**

- **Always shut OFF the engine while refueling.** Do not smoke and do not operate other ignition sources while refueling.
- **When the propane container is disconnected from the main supply hose** and the P.O.L. connection, install the P.O.L. plastic cap that is attached to the container.
- **If you suspect your propane container has been overfilled, contact your dealer or a qualified propane technician for assistance immediately.** Do not attempt to service a propane container overfill yourself.

**PROPANE GAS CONTAINER (See page 53)**

Transport and store DOT propane cylinders upright to ensure proper functioning of the pressure relief device; laying them on their side can be dangerous. Install the pigtail hose to prevent tension or pulling stress, and keep it away from sharp edges and compartment structures. Before entering a propane or fuel service station, extinguish all pilot lights, shut off gas to all appliances, and turn off any engines. Refrain from smoking or operating ignition sources while refueling. If you suspect overfilling of your propane container, seek assistance from your dealer or a qualified propane technician immediately; do not attempt to address it yourself.

# SECTION 8: PLUMBING SYSTEM



## PLUMBING SYSTEM

There are two different water systems in your recreation vehicle:

- The fresh water system consists of the fresh water holding tank, faucets and connections, water pump, water heater, tub/shower. On some models, it may also include the water purification system or outside shower assembly (if so equipped).
- Depending on your model, the waste water system consists of the wastewater and sewage holding tank(s), drains and toilet. Models with a cassette toilet will only have the wastewater system.

### Plumbing System Maintenance

- Check all fittings, pressure and waste, for leaks before each trip or before vehicle storage as part of your normal maintenance:
- Inspect all faucets, the water purification system (if so equipped) and sink connections (including drain baskets or filters).
- Inspect connections at the water pump and water heater (if so equipped).
- At the end of every trip, you should drain any unused water from the fresh water system.

Typically, there are labels affixed to the exterior of the recreation vehicle sidewall that indicate the locations of the water system drains and fills. Be aware some drain valves may be located inside the vehicle (once the exterior label is found, go inside to find the drain corresponding location).

Refer to the manufacturer's operating manual included in your warranty packet for the detailed operating, sanitizing, and winterizing information for each water system component.

## MONITOR PANEL



Monitor Panel

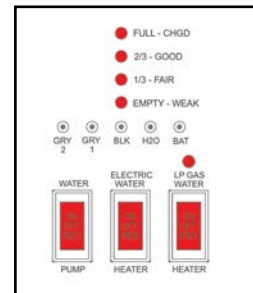

Command Center Example  
(Components and Appearance may vary)

Monitor panel locations may vary by model. Typical locations are on the command center panel, Firefly screen, on an interior wall, or on the exterior utility center. Some models may be equipped with a touch screen system that monitors tank levels electronically. The monitor panel allows you to monitor the fresh water, grey water, black water and auxiliary battery levels. These functions are controlled using the tact switches. It operates on 12-volt DC power supplied by either the converter or auxiliary battery. No power is drawn from the battery unless a switch is pushed or turned ON. Fuses for the monitor panel are located in the load center. Refer to the manufacturer's operators manual for additional information.

## NOTE

If your RV has secondary black or gray tanks, there may be an additional tank monitor. It is typically labeled as a convenience center.

## Operation

Press only one tact switch at a time. As you push either the FRESH, BLK GREY1 or GREY2 switch, one or more LED lights will illuminate (from left to right) indicating the content level for that tank. When pushing the “BATT” switch, the LED lights illuminate from left (lowest) to right (highest) to indicate the estimated auxiliary battery condition.

## NOTE

When using shore power all (4) LEDs will light. If disconnected from shore power, (3) LEDs will light to indicate a full charge (4th LED may blink).

The LEDs on the panel indicate the following:

**C** = Charge at 12.7 volts

**G** = Good at 12.1 volts

**F** = Fair at 11.6 volts

**L** = Low at 6.0 volts

Tank monitors on the touch screen have a constant readout. There are no buttons to push. Tank levels are displayed by percentage from 0% to FULL.

## Level Alert Button

When this LED flashes a tank requires attention. To silence the alarm press the level alert button.

## Water pump switch

This switch may be located on the monitor panel, the utility center, or both. On some models, the water pump control may be on one of the selectable screens for the touch screen. When the water pump switch is ON (lit), the water pump will run until it reaches 45 lbs. of pressure. It will recycle when pressure drops. Turn the switch OFF when the water pump is not being used.

## Water heater switches

These switches can be located on the monitor panel, the command center, or in the case of a touch screen system, on one of the selectable screens of the touch screen. Switches will light up when turned on. The “LP GAS” water heater switch (12V) enables propane operation of the water heater, and the “ELECTRIC switch (120V) enables electric operation of the water heater. Normally both switches should be turned on to provide the fastest hot water recovery time. The water heater can be operated in electric only or gas only modes by pressing each switch independently. If the RV is equipped with a tankless water heater, there will be only an LP Gas switch on the command center panel.

## DSI FLT - Direct Spark Ignition Fault

This light located between the water heater switches will indicate a problem with the LP portion of the water heater. When the LP GAS switch is turned on, the light will blink quickly 3 times and the water heater will ignite. The light will then remain off. If the light comes on and stays on, it indicates the gas side of the water heater has not fired and there is a problem with the igniter.

## NOTE

This light will not appear on touchscreens, RV remote controls or on a Wi-Fi app, only on the Command Center switch panel.

## FRESH WATER SYSTEM

**⚠ WARNING ⚠** (See page 70)

All water contains contaminant and mineral particles that can cause fresh water system odors. Untreated well water is a major source of water system odors. The fresh water (potable water) system needs periodic sanitization to take care of all the components in the plumbing system to discourage the growth of bacteria and other organisms that can contaminate the water supply.

Do not remove the potable water label from your recreation vehicle.

You should use a non-toxic drinking water hose dedicated only to supplying the recreation vehicle with fresh water. To reduce the chance of contamination, prevent the non-toxic drinking water hose from coming into contact with the ground.

## ⚠ WARNING

POTABLE WATER ONLY. SANITIZE, FLUSH AND DRAIN BEFORE USING. SEE INSTRUCTION MANUAL. FAILURE TO COMPLY COULD RESULT IN DEATH OR SERIOUS INJURY.

AD-04

Potable Water Label

## NOTE

If needed, sanitize the water system prior to travel.

## Water Pressure Regulator (customer supplied)

**⚠ CAUTION ⚠** (See page 72)

Excessive pressure from the water supply source may be encountered in some parks, especially in mountain regions when using the fresh water inlet or black tank flush. Water pressure regulators are available to protect your recreational vehicles plumbing system against such high pressure.

## Fresh Water Holding Tank

**⚠ CAUTION ⚠** (See page 71)

There may be several ways to fill the fresh water tank depending on the model. For details of each method, refer to the *Utility Center or Water Connection* section. There are plastic overflow tubes in the fresh water holding tank which allow water to flow out of the water tank. Occasionally, you may see water coming from the overflow tubes when the fresh water holding tank is filled. This is normal and can be a result of the recreation vehicle being parked on an incline, or the motion caused by starting or stopping during travel.

## 12-volt Water Pump

There must be sufficient 12-volt DC power to run the water pump when your recreation vehicle is not hooked up to city water. Once activated, the water pump (also known as the demand pump) will self-prime, and provide

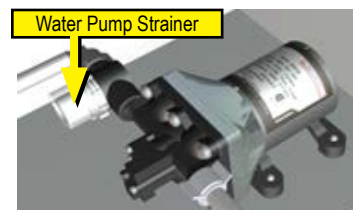

water. The water pump continues to run until maximum pressure is achieved and shut off. The water pump will automatically re-start when it senses a drop in the water pressure. The pump is designed for **intermittent use only**. Using the pump continuously or with high pressure will shorten the life of the pump and is not covered in your warranty.

Some cycling may occur, depending on the volume of water being released. The water pump is engineered with a check valve to prevent water from back flowing into the fresh water supply tank.

## NOTE

The water pump switches should be in the OFF position when the recreation vehicle is left unattended for any amount of time.

### Maintenance

Periodically check the in-line water pump strainer for accumulated debris. To clean, shut off the water pump, unscrew the clear cap, remove the re-useable metal strainer, clear any debris, then reinstall.

Normal pump maintenance consists of checking and cleaning of the strainer, normal sanitizing and winterizing and occasionally checking all plumbing hardware and fittings for tightness. Lack of sanitizing can lead to premature pump failure and poor performance over time. Scale build-up on the diaphragm and valves, can cause low flow and leak back (occasional pump cycling with no faucets open or tank filling up when hooked up to city water).

For additional information on the care and operation of the pump, read the safety and operating information in the pump manufacturer's owner's manual.

### Water Pump Switch

Most water pump switches illuminate when the water pump is activated. Typical switch locations are in the back of the unit or on the monitor panel, or the switch may be part of a touchscreen system (if so equipped). When the water pump switch is ON the pump runs until 45 lbs. of pressure has been achieved. The red light will stay on.

## DRAINING THE FRESH WATER SYSTEM

Water tanks may be drained through a valve located near the tank. A recreational vehicle with a demand pressure pump system will have low-point drains attached to the water lines (normally located near the water tank).

These low-point drains will release water in the supply lines by opening the valves and all faucets. The water heater has its own drain plug. To drain the permanent fresh water holding tank and supply lines:

1. Turn the water heater power OFF (turn off the electric and LP gas switches).
2. Open all faucets, including the outside shower faucet (if so equipped).
3. Open the "fresh tank drain" valve. Methods to drain the fresh water tank may vary by model. Fresh water tanks can be drained by one of the following methods:
  - A white plastic drain attached to the exterior wall
  - A valve located inside the RV adjacent to the water tank (turn 45° to open or close).
  - Pull the white "T" handle on the fresh water holding tank to drain the water
4. Low point drains are installed at the lowest point of the water lines. A label is placed on the outside of the RV to indicate where the drains are located. The type of drain may vary by model. You will have either an interior or exterior drain.



Exterior Fresh Water Drain

- Interior drains: the drains will need to be operated from inside the RV. Once the label is found on the exterior sidewall, the drains will be found at a corresponding location in the interior.



Low Point Drains - Some Models

- Exterior drains: Open the "low point drains" by removing the black screw on caps on the water lines (coming out from the underbelly). The drains will typically need to be opened from outside the RV.
5. Drain the sink by removing the drain cap.
  6. Turn ON the water pump and allow it to run as needed.
  7. Open all faucets, including the outside shower faucet. Make sure the "water heater bypass" valve is open.
  8. Operate the toilet flush lever until water stops flowing.
  9. If the RV water heater has bypass valves, set them to the BYPASS configuration (refer to the *Water Heater Bypass section*).
  10. Relieve the water pressure using the P&T valve BEFORE removing the water heater drain plug. If there is any water pressure present, the water will spray out of the opening when the drain plug is removed.

It is normal for some liquid to remain in the fresh water tank after drainage procedure. When you are finished draining the fresh water system, reverse these steps and, dump the grey and black water holding tanks at an appropriate facility or according to local public codes.

## THE PLUMBING SYSTEM; SANITIZING AND WINTERIZING

### The Plumbing System with NO Utility Center

#### Water Heater Bypass

Most models have a factory installed water heater bypass that enables you to avoid filling the water heater with RV antifreeze. The 2-Valve Bypass is typically located in close proximity to the water heater.



#### Water Heater Switches

The water heater switches are typically located on the monitor panel. Refer to the *Monitor Panel section* for function details.

## NOTE

- A short hose is supplied with your motor home for use in sanitizing or winterizing the water lines in your RV. It can also be used to siphon fill the fresh water tank when no city water is available. One end of this hose has a fitting that will screw onto the city water connection inlet allowing the other end to be put into a container of fresh water, sanitizer or RV antifreeze (refer to Sanitizing and Winterizing).
- If needed, sanitize the water system prior to travel.

## The Plumbing System with Utility Center

Water valve settings indicated on the utility center label:

- **City Fixtures** - Allows you to access water from all faucets using a pressurized water source (referred to from here on as “city water”).
- **City Fill Tank** - Allows you to fill your fresh water tank using city water.
- **Country Fill** - Allows you to siphon fill your fresh water tank (using the 12-volt water pump) when you do not have access to city water.
- **Normal** - If the RV is not connected to city water, allows you to pump water from the fresh water tank to all faucets using the 12-volt water pump.
- **Sanitize/Winterize Lines** – Allows you to sanitize or winterize the water lines
- **Sanitize Tank** – Allows you to sanitize the fresh water tank. Depending on your model, the city water connections may be configured one of three ways:



Fig.A - Water Valve Controls



Fig.B - Utility Center



Fig.C - Utility Center

1. A water valve control panel (**Fig A**). The city water connection inlet will be located on the outside of the motor home, and the pump switch inside on the monitor panel.
2. A horizontal utility center (**Fig B**). This utility center contains the city water connection inlet, pump switch, water valve controls, outside shower, black tank flush inlet and a macerator discharge system.
3. A vertical utility center (**Fig C**). This utility center contains an outside shower, city water connection inlet, black tank flush inlet, pump switch and water valve controls.

## Water Valve Control Operation

**City Fixtures:** Use this setting if the motor home can be hooked up to an external pressurized water source (city water). If needed, sanitize the water system prior to travel.

1. Move the water heater bypass valves (if so equipped) to the NORMAL position (supply line valves ON, middle mixer valve OFF). The tankless water heater has no bypass.
2. Remove the city water connection inlet cap and attach a non-toxic drinking water hose to the city water connection inlet and the other end to a pressurized water source.
3. Place the utility center valves in the CITY FIXTURES position. (**Fig A**).
4. Turn on the water at the external water source.
5. Enter the motor home and open the cold water supply faucets to bleed air from the water lines. When the water lines are nearly full, you may experience some “air pockets”. Allow these to escape before closing the cold water supply faucets.
6. The tank (storage) water heater (if so equipped) will fill first, followed by the supply lines and faucets.
7. Turn the (12-volt Gas or 120-volt Electric) storage water heater power switch ON. For a tankless water heater, turn the water heater power switch ON (located outside at the water heater panel). The water will be heated on demand.

## To disconnect

8. Shut off the water at the external water source and disconnect the hose.
9. Disconnect the non-toxic drinking water hose from the city water connection inlet and reinstall the city water connection inlet cap.

**City Fill Tank:** Use this setting to fill the water tank from a pressurized water source. If equipped with a tank (storage) water heater, set the bypass valves to the NORMAL position (supply line valves ON, middle mixer valve OFF). The tankless water heater has no bypass valves.

1. Remove the city water connection inlet cap. Attach a non-toxic water hose to the city water connection and the other end to a pressurized water source.
2. Place the utility center valves in the “CITY FILL TANK” position (**Fig A**).
3. Turn ON the water at the external source. Water will flow into the fresh water tank.

During the filling process, periodically check the fresh water tank level using the monitor panel located in the command center. When the fresh water tank is full, it is normal to see water running from the fresh water overflow tubes onto the ground.

## To disconnect

1. Shut OFF the water at the external water source.
2. Disconnect the non-toxic drinking water hose and reinstall the city water connection inlet cap.

## PLUMBING SYSTEM

**Country Fill:** This setting is used to siphon fill the water tank from a water container when dry camping and a pressurized water source is unavailable.

1. If equipped with a tank (storage) water heater, set the bypass valves to the NORMAL position (supply line valves ON, middle mixer valve OFF). The tankless water heater has no bypass valves.
2. Remove the city water connection inlet cap and attach one end of the short hose supplied with the motor home to the city water connection inlet, and the other end into a container of fresh water.
3. Place the utility center valves in the COUNTRY FILL position (**Fig A**).
4. Turn water pump ON. Water should begin to be drawn out of the container and into the fresh water tank. To aid siphoning place the container on a flat surface approximately 2 feet off the ground. All low point drains must be off in order to create a siphon.

During the filling process, periodically check the fresh water tank level using the monitor panel located in the command center. When the fresh water tank is full, it is normal to see water running from the fresh water overflow tubes onto the ground.

### To disconnect

5. Shut OFF the water pump.
6. Disconnect the short water hose and reinstall the city water connection inlet cap.

**Normal Setting:** Allows you to use the water system when dry camping. The water pump circulates water from the fresh water tank to all the fixtures.

1. If equipped with a tank (storage) water heater, set the bypass valves to the NORMAL position (supply line valves ON, middle mixer valve OFF). The tankless water heater has no bypass valves.
2. Place the utility center valves in the NORMAL position (**Fig A**).
3. Turn the water pump ON (make sure you have sufficient 12-volt power).
4. Water will be pumped from the fresh water tank to all faucets.
5. The tank (storage) water heater will fill first, followed by the supply lines and faucets.
6. Enter the motor home and open the cold water supply faucets to bleed air from the water lines. When the water lines are nearly full, you may experience some "air pockets". Allow these to escape before closing the cold water supply faucets.
7. Turn the appropriate (12-volt Gas or 120-volt Electric) storage water heater power switch ON. If equipped with a tankless water heater, turn the water heater power switch ON (switch is located outside the RV at the water heater panel). Water will be heated on demand.

**Sanitize Tank:** This setting is used to sanitize the fresh water tank. When the fresh water tank drain and the low point drains are closed, a siphon is created in the water lines allowing sanitizer to be pulled into the fresh water tank from an external container (see Sanitization section).

**Sanitize / Winterize Lines:** This setting is used for drawing RV antifreeze into the water lines of the motor home. When the fresh water tank drain and the low point drains are closed, a siphon is created in the water lines allowing antifreeze to be pulled into the water lines. This setting will not allow antifreeze into the fresh water tank (see Winterization section).

### Sanitizing the Plumbing System

#### When to sanitize

- When your motor home is new.
- At the beginning and end of each season.
- Every three months of use.
- If the water system becomes contaminated.

#### Preparing to sanitize

Prepare a chlorine solution using 1/4 cup of household bleach (sodium hypochlorite solution) to one gallon (3.785 liters) of water in a container. Prepare one gallon of solution for every 15 gallons of tank capacity. This will result in a residual chlorine concentration of 50 ppm in the water system and should remain in system for at least 4 hours.

If a 100 ppm concentration is prepared, use 1/2 cup of household bleach with one gallon of water. One gallon of the solution should be used for each 15 gallons of tank capacity. Allow to remain in system for at least 1 hour.

## NOTE

Fresh water tank sizes vary by model. Contact your dealer or customer service for your specific tank size.

1. Turn water heater power OFF (storage style-both electric and LP gas switches; tankless water heater power switch).
2. Level the RV and drain the fresh water system (see *Draining the Fresh Water System*).
3. Close the low point drain valves and the fresh water tank drain valve.
4. Remove the water filter from the full system canister in the basement area of the motor home (see *Water Purification section*). Re-attach the empty canister and turn the water supply valves at the filter ON.

#### How to sanitize (NO UTILITY CENTER)

1. Set the water heater bypass valves to BYPASS (refer to *Water Heater Bypass Valves section*).
2. Put the sanitizer solution in the fresh water tank: Insert one end of a hose or funnel in the gravity fill inlet, insert the other end into a container holding the chlorine solution. **Do not use your non-toxic drinking water hose.** Pour the chlorine solution into the gravity fill.

## NOTE

For complete sanitizing of the fresh water tank, the unit should be driven around for a brief time allowing the solution to splash the sides and top of the tank.

3. Remove the hose or funnel and container used to pour the chlorine solution, and continue filling the fresh water tank with clean (potable) water until tank is full. Pour fresh water into the gravity fill inlet until tank is completely full.
4. After the recommended amount of sanitizing solution is in the tank, the water tank is full, and water filter has been removed, turn the pump ON which sends sanitizer into the water lines.

## NOTE

The full system canister must have the filter removed. Water heater must be BYPASSED.

5. Open all hot water faucets one by one until water begins to flow continuously and a chlorine smell is noticeable. Include outside shower faucets (if so equipped).
6. Close the hot water faucets and repeat opening all cold water faucets one by one until you smell chlorine. Include the toilet and outside shower faucets (if so equipped).
7. Turn OFF the water pump.
8. Let the solution remain in the tank and lines for at least four hours when disinfecting with 50-PPM residual chlorine, and for at least one hour if using a 100-PPM chlorine concentration.

## NOTE

For complete fresh water tank sanitization, driving your unit around for a short distance will allow the sanitizing solution to splash around all sides of the tank.

9. After the required period, drain the chlorine solution from the fresh water system (see *Draining the Fresh Water System*). Since the water heater was bypassed there should be no sanitizer in the tank water heater.
10. Rinse the system with fresh water
11. Fill the fresh water tank full of clean (potable) water. Fill fresh water tank from an external container. Pour fresh water into the inlet using a hose (or funnel).
12. Power to water heater should be OFF (both switches: electric and LP gas). When the fresh water tank is full, turn the pump ON to send water through the lines.
13. Run water through all faucets (hot and cold, including outside shower) until chlorine smell is gone. Turn faucets and outside shower off, turn pump OFF.
14. Drain the fresh water system again (see *Draining the Fresh Water System*).
15. Set water heater bypass valves to NORMAL (if so equipped) close bypass valve, open valve on water heater, replace water heater drain plug.
16. Refill the fresh water tank with fresh water and when water heater is full of water, turn the water heater power ON.

**Lingering Chlorine Taste:** If a chlorine taste still lingers in the water, flush the water system with a solution consisting of one-quart vinegar to five gallons of clean water. Re-flush as necessary. The vinegar solution may damage the water heater or the water filter, so both must be bypassed again before performing this operation.

- Follow the steps outlined in *Draining the Fresh Water System* with one exception; do not drain the water heater.
- Water heater bypass valves (if so equipped) should be set to BYPASS. Do not remove the water heater drain plug.
- Full system canister water filter, remove the canister, take out the filter, and reattach the empty canister.

### After draining the system

1. Water heater power should be OFF (both switches: electric and LP gas).
2. Put the vinegar solution into the fresh water tank. Pour the vinegar solution into the gravity fill using a hose (or funnel).
3. Continue filling the fresh water tank with of clean (potable) water. Pour fresh water into the gravity fill inlet using a hose (or funnel).
4. Run water through all faucets (hot and cold, including outside shower) until chlorine smell is gone. Turn the pump ON to send water through the lines.
5. Close all faucets including outside shower. Turn pump OFF.
6. Drain the system again, but don't drain the water heater. Do not remove water heater drain plug.
7. Close low point drains and fresh water tank drain.
8. Refill the fresh water tank with clean potable water. Use the gravity fill, pour water directly into the gravity fill inlet on the outside of the trailer.
9. Open faucets and check that the chlorine taste is gone.
10. Drain the system one more time (see *Draining the Fresh Water System*).
11. Remove full system canister, insert the filter, and reattach canister to the mount.
12. Refill the fresh water system with clean water. When the water heater is full of water, turn the water heater power ON.

### How to sanitize (WITH UTILITY CENTER)

1. Bypass the (storage) tank water heater. **Sanitizer should be kept out of the water heater.** The tankless water heater does not have bypass valves.
2. Attach the short hose supplied with your recreation vehicle to the fresh water connection inlet (on the utility center or on the outside of the motor home). Place the other end of the hose in a container holding the sanitized solution. To aid in siphoning, set the container on a surface approximately (2) feet off the ground. The drain valves must be turned OFF.
3. Place the utility center valves in the SANITIZE TANK position.
4. Turn the water pump ON.

## PLUMBING SYSTEM

5. Solution will be drawn into the fresh water tank. When all the solution is in the tank, set the utility center water valves to the city fill tank position.
6. Remove the container and the short hose from the fresh water connection inlet.
7. Attach the hose to the fresh water connection inlet and attach the other end to a potable pressurized water source.
8. Turn on the pressurized water source and finish filling the fresh water tank. Monitor the tank level while filling; **DO NOT OVERFILL THE TANK.**

### NOTE

For complete fresh water tank sanitization, driving your unit around for a short distance will allow the sanitizing solution to splash around all sides of the tank.

9. When the tank is full, turn off the water source, disconnect the hose from the water source, and remove it from the fresh water connection inlet.
10. Set the utility center valves to the NORMAL position.
11. Turn the water pump ON.
12. Open all hot water faucets one by one until water begins to flow continuously and a chlorine smell is noticeable. Include outside shower faucets (if so equipped).
13. Close the hot water faucets and repeat opening all cold water faucets one by one until you smell chlorine. Include toilet and outside shower faucets (if so equipped).
14. Let the solution remain in the system for at least four hours when disinfecting with 50 PPM residual chlorine. If a shorter time is desired, a 100 PPM chlorine concentration should be used for at least one hour.
15. After the required period, drain the chlorine solution from the fresh water system (see *Draining the Fresh Water System*). Since the water heater was bypassed there should be no sanitizer in the (storage) tank water heater.

### Rinse the system with fresh water

16. Re-fill the fresh water tank using clean (potable) water. Refer to *Country Fill* or *City Fill in Utility Center* section to re-fill the tank. If city water is not available, the tank can be siphon (country) filled.
17. Set the tank water heater bypass valves to normal, hot and cold supply lines ON, middle (mixer) valve OFF.
18. Set utility center water valves to the NORMAL position and turn the pump ON to circulate fresh water through the lines.
19. Open hot and cold lines to all faucets and outside shower until chlorine smell is gone.
20. Restore power to the tank water heater only when it is full of water. For a tankless water heater, turn the power switch ON (water is heated on demand).

**Lingering Chlorine Taste:** If a chlorine taste still lingers in the water, flush the water system with a solution consisting of one-quart vinegar to five gallons of clean water. Re-flush as necessary. The vinegar solution may damage the water heater or the water filter, so both must be bypassed again before performing this operation. To add the vinegar solution, follow the same procedure used to add the sanitizer to the system. Refer to the *Lingering Chlorine Taste* detail in the previous section for instructions on how to flush the system with the vinegar solution.

### Winterization

**⚠ WARNING ⚠** **⚠ CAUTION ⚠** (See page 70) & (See page 72)

Preparing your motor home for colder weather or storage is very important for most states and Canada. Failure to prepare your motor home may cause water supply lines and the water heater to freeze.

The motor home should be winterized at the end of the camping season or when the motor home will be exposed to temperatures that will fall at or below 32°F (0°C). Repairs due to freezing are not covered by warranty.

Your motor home may be equipped with a utility center. The winterizing process is different for units with a utility center than it is for units without one. The following sections will address both applications. It may be easier to winterize the motor home with another person to assist you.

**No commodity or product should be added to the fresh water system to ensure freeze protection other than RV antifreeze.**

### NOTE

- Appliances (refrigerator, dishwasher or clothes washer) must be winterized. Refer to the appliance owner's manual for additional information or contact your Dealer or Customer Service for assistance.
- The preferred method is to winterize the plumbing system with RV antifreeze. Please read, understand and follow all instructions before beginning to winterize your motor home.
- The tank water heater must be drained to prevent damage from freezing. The water heater should be drained and bypassed during the winterization process particularly if introducing RV antifreeze into the plumbing system. **DO NOT DRAIN THE WATER HEATER WHILE IT IS HOT OR UNDER PRESSURE!** Antifreeze should be kept out of the water heater.

### Winterizing with Antifreeze Method (NO UTILITY CENTER)

1. Turn water heater power OFF. Turn water heater gas valve (if so equipped) OFF (outside of the RV).
2. Level the RV and drain the fresh water plumbing system. (See *Draining the Fresh Water System*).
3. Bypass the water heater. Water heater bypass valves: A and B should still be closed, valve C open. Remove the water heater drain plug. **DO NOT REMOVE THE DRAIN PLUG WHILE THE WATER HEATER IS HOT OR UNDER PRESSURE.**
4. Make sure the "fresh water tank drain" and "low point drains" are closed.

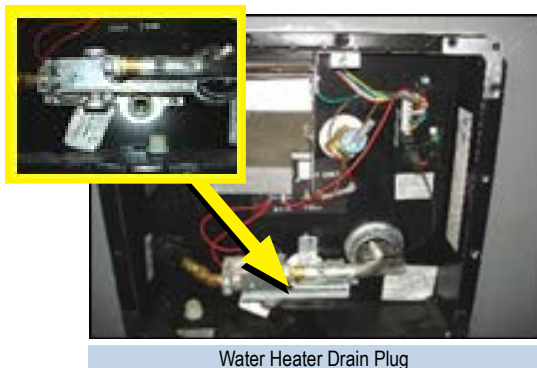

Water Heater Drain Plug

5. Close the fresh water tank shutoff valve “D” (if so equipped). Valve should be located in the vicinity of the water pump.
6. Open valve “E” on the water pump with the clear hose attached and insert the opposite end of the clear hose into a container of RV antifreeze solution. Valve should be located in the vicinity of the water pump.
7. Turn the water pump ON. Antifreeze will be drawn into the water lines.
8. Open the hot water faucets, including outside shower (if so equipped) until RV antifreeze begins to flow continuously.
9. Close the hot water line faucets and outside shower and repeat with the cold water line faucets. Hold open the lever on the toilet until antifreeze runs into the bowl.

### When you are finished adding RV antifreeze

10. Turn the water pump OFF. Turn valve E OFF. Remove the clear hose from the container of RV antifreeze. Leave the water tank shutoff valve D closed to keep antifreeze out of the fresh water tank.
11. Pour 1 cup of RV antifreeze into the sink drain P-trap.
12. To prevent staining, wipe the RV antifreeze out of the sinks, shower (or tub) and toilet using a soft, dry cloth.

## NOTE

In the spring when flushing antifreeze out of the water lines make sure to turn valve D (the fresh water tank shutoff) back ON.

If needed, contact your RV dealer for assistance.

### Winterizing with Antifreeze Method (WITH UTILITY CENTER)

13. Level the motor home and drain the fresh water plumbing system.
14. Turn the water valves OFF on each side of the water filter canister. The canister is located behind the utility center. Unscrew the canister and remove the filter. Re-attach the empty canister and turn the water valves ON (refer to the *Water Purification section*).
15. Water heater power switches (12V gas & 120V electric at the command center) should be turned OFF. Gas valve at the water heater should be turned OFF. The tankless water power switch is located outside the RV.

16. Turn the water heater bypass valves (if so equipped) to the BYPASS position. Remove the water heater drain plug. **DO NOT REMOVE THE DRAIN PLUG WHILE THE WATER HEATER IS HOT OR UNDER PRESSURE.** Tankless water heater will not have bypass valves.
17. Move the valves to the “Sanitize/Winterize Lines” position. The low point drains must be closed for the antifreeze to siphon through the lines.
18. Attach the short hose supplied with the motor home to the fresh water connection inlet and insert the other end of the hose into a gallon container of RV antifreeze. To assist the siphoning process, put the container on a surface approximately two feet above ground level.
19. Turn the water pump ON. Antifreeze will be drawn into the water lines.
20. Open the hot water line on all the faucets (kitchen, lavatory, shower and outside shower) until RV antifreeze begins to flow continuously.
21. Close the faucet hot water lines and repeat with the cold water lines on all the faucets. Flush the toilet a couple of times until you see antifreeze in the bowl.

### When you are finished adding RV antifreeze

22. Remove the short hose from the container of RV antifreeze.
23. To prevent staining, wipe the RV antifreeze out of the sinks, shower (or tub) and toilet using a soft, dry cloth.

If needed, contact your RV dealer for assistance.

### Winterize the Macerator System (if so equipped)

**⚠ CAUTION ⚠** (See page 72)

If your motor home comes equipped with a macerator system, it can retain water in the flexible hose, the dump connector attached to the flex hose, and the macerator box and pipe.

Pour antifreeze into the dump connector and into the 1-1/2-inch flexible hose. Then raise the hose allowing the antifreeze to run back down to the macerator pump. Return the flex hose and dump connector to the storage box.

### WATER HEATER - TANK (IF EQUIPPED)

**⚠ WARNING ⚠** (See page 70)

Your RV may be equipped with a tank (storage) water heater.

#### Tank (Storage) Water Heater

The water heater manufacturer has preset the sensing limit to maintain the water temperature when the water heater is activated. Read the safety and operating information in the manufacturer’s user guide before attempting to activate the water heater.

#### Gas/Electric DSI Tank (Storage) Water Heater System

Make sure the water heater is filled with water before use as even momentary operation of the water heater without water in it may result in damage to the tank and/or controls. Always open both the hot and cold water faucets when filling the fresh water tank to allow air pockets to be forced out of the water heater. The thermostat on your water heater is not adjustable and is designed to maintain a water temperature of 130°F (54°C).

## PLUMBING SYSTEM

The water heater does not have a pilot. It is equipped with an ignition device which automatically lights the burner. Do not try to light the burner by hand.

### Operating instructions

1. Turn OFF all electric power to the water heater.
2. Turn OFF the propane supply. Wait five minutes for the propane to clear the area. **If you smell propane, STOP!** Follow the safety instructions listed in the manufacturer's owner's manual. If you do not smell propane, go to the next step.
3. Turn ON the propane supply.
4. Turn ON electrical power to the water heater.
5. Turn the switch to the "ON" position. If the burner does not light, the system will automatically attempt two more tries for ignition before lock-out occurs.

### NOTE

Each ignition cycle will have a 15 second purge before spark cycle if the system is a three try system.

6. If lock-out occurs before the main burner lights, turn the water heater control switch to OFF, wait five seconds and turn the switch to the ON position. This will restart the ignition cycle.
7. The first start-up of the heater may require several ignition cycles before all the air is purged from the propane lines.

If the burner will not come on, the following items should be checked before calling a service person:

1. See if the switch is turned OFF.
2. Make sure the propane supply to the water heater is not empty or turned OFF.

Check to see if the reset button on the water heater ECO is tripped.

### Water Heater Switch

The "propane GAS" switch enables propane operation of the water heater, and the "ELECTRIC" switch enables electric operation.

### NOTE

Water heaters in some models will ONLY have a single LP Gas water heater switch. These units will not heat water electrically.

### Water Heater Bypass

Your RV may be equipped with a water heater bypass. This three-valve system is located at either the water heater, or on the utility center panel depending on your model. For detailed information refer to the *Utility Center or Fresh Water System sections*.

### Odor from the hot water system

Many water supplies contain sufficient amounts of sulfur to produce an odor, often called "sulfur water". Sulfur water can be caused by a chemical action or by bacteria. Generally, sulfur water is not harmful, only unpleasant to smell. Refer to the water heater manufacturer's manual for details on eliminating the odor from sulfur water. Odor from sulfur water is not a service problem.

### High altitude deration

Operation of the water heater at high altitudes may require derating. If the water heater is not properly derated, lack of sufficient oxygen for combustion may produce improper burner operation. Pilot outage caused by burner lift-off or sooting from a yellow burner may occur, indicating the possibility of carbon monoxide. You may also notice a lack of efficiency in heating the water because of incomplete combustion of the burner at these higher altitudes. Consult with the local propane company, your dealer or the water heater manufacturer for proper derating of the water heater. Change out of the orifice (derating) should be done by the dealer or a qualified service agency.

### NOTE

It is important that once the RV has returned to lower elevation (below 4500 feet) any high altitude deration or other adjustments be reversed for proper operation of the water heater.

### Pressure and Temperature Relief Valve

**⚠ WARNING ⚠** (See page 70)

The temperature and pressure relief valve is designed to open if the temperature of the water within the heater reaches 120° F, or if the water pressure in the heater reaches 150 pounds. When this pressure is reached, the pressure relief valve will open and water will drip from the valve.

This "weeping" or dripping will continue until the pressure is reduced to below 150 pounds, and the valve closes. This condition is normal and does not indicate a defective relief valve.

One way to reduce the frequency of this occurrence is to maintain an air pocket at the top of the water heater tank. This air pocket will form in the tank by design; however, it will be reduced over time by the everyday use of your water heater. To replenish this air pocket:

1. Turn off the water heater.
2. Turn off the cold water supply line.
3. Open a faucet in the RV.
4. Pull out the handle of the pressure relief (P&T) valve and allow water to flow from the valve until it stops.
5. Release the handle on the P&T valve - it should snap closed.

Close the faucet and turn on the cold water supply. As the tank fills, the air pocket will develop. Repeat this procedure as often as needed to reduce the frequency of the weeping P&T valve.

### Maintenance

Do not allow the burner to burn with a yellow flame, or continue to operate the water heater with an improper burner flame. Periodically, inspect the water heater vent for soot. Soot is a sign of incomplete combustion and must be corrected before operating the water heater. This is your visual warning that the water heater is operating in an unsafe manner. If soot is present, immediately shut the unit down and contact your dealer or a qualified service agency.

Periodically inspect the vent for obstructions. Do not terminate the vent on your water heater inside of add-on rooms, screen porches or patios. Doing so will result in products of combustion being vented into the rooms or occupied areas.

## Draining and Winterization

If the recreation vehicle is to be stored over the winter months, the water heater must be drained to prevent damage from freezing. Damage to the water heater caused by freezing is not warrantable. It is recommended the water heater be drained and bypassed during the winterization process, **particularly if introducing RV antifreeze into the plumbing system. Never drain the water heater when it is HOT or UNDER PRESSURE.**

To drain the water heater:

1. Turn off electrical power to the water heater either at the switch from the electrical element of at the breaker.
2. Shut off the propane supply to the water heater.
3. Turn off the water pump.
4. Open both hot and cold water faucets.
5. Remove the anode rod from the tank.

For detailed information see the *Winterization* section.

## TRUMA® COMBI DIESEL 2 in 1 SYSTEM (IF EQUIPPED)

**⚠ WARNING ⚠ ⚠ CAUTION ⚠** (See page 71) & (See page 52)

Your recreation vehicle may be equipped a Truma® Combi furnace with supplementary indirect water heating. Refer to the manufacturer's owner manual, for important operating and safety information.

## TRUMA® ON DEMAND WATER HEATER (IF EQUIPPED)

**⚠ WARNING ⚠ ⚠ CAUTION ⚠** (See page 70) & (See page 71)

Your recreation vehicle may be equipped with a Truma® on demand water heater. The on demand water heater has no pilot light and supplies an unlimited supply of hot water on demand. It does not require an anode rod to prevent corrosion, and is not affected by high altitudes. The output temperature of the water depends on the temperature of the inlet water AND the amount of hot water that is drawn. If the inlet water temperature is over 65°F, the on demand water heater will generate water in the range of 113°F to 120°F depending on the water flow selected by the user.

## NOTE

A pressure regulator is recommended to be used on your pressurized water line to maintain water pressure around 45 PSI.

## Opening the exterior water heater panel

## NOTE

The panel will only open enough to access the power switch on the inside. This is intentional. **DO NOT TRY TO FORCE THE PANEL OPEN FURTHER.**

- Turn the locking knob, and open the exterior water heater panel to the first open position (photo A).
- To open the panel to the **second** (or service) position, the door must first be open as shown in (A). Then lift the door so it comes out of the slots along the bottom of the door (photo B).
- Lower the door so it lays flat against the RV hanging down by the straps (photo C).

- To close the door, insert the tabs back into the slots at the bottom of the door, close the panel and rotate the locking knob. Make sure the straps are not pinched between the door and the cover plate.



## Filling the water heater

- Turn on the fresh water supply or switch on the water pump.
- Fill the plumbing system. Open all faucets, showers, toilet to bleed air from the lines.
- When water begins to flow out of the faucets, the system is vented.
- Close all fixtures.

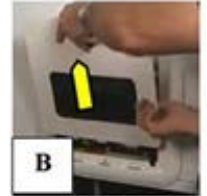

## Turn water heater ON

- Make sure the LP gas supply is turned ON.
- Turn on the 12VDC power in the RV.
- Open the water heater access door.
- Turn the power switch on by selecting either ECO or COMFORT position. The green LED (1) will light at the top of the power switch.
- If the RED LED (2) below the switch lights or flashes, it indicates an error condition. Refer to the appliance owner manual for error codes.



## NOTE

The Aqua Go BASIC water heater will NOT have the ECO/COMFORT settings. It only has a basic power switch. It should NEVER be operated in freezing conditions. If the vehicle is standing and ambient temperatures are below -4°F (-20°C) the appliance must NOT be operated and MUST be winterized.

## Maintenance

Inspect your water heater monthly and have it serviced at least once a year by the manufacturer's recommended service technician. Contact your RV dealer, the manufacturer or Customer Service.

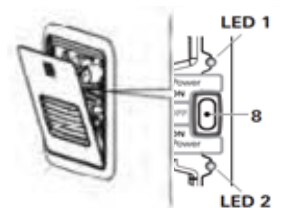

Aqua Go Basic Power Switch

## Pressure – Temperature Relief Valve

**⚠ WARNING ⚠** (See page 71)

**THIS VALVE IS A SAFETY COMPONENT AND MUST NOT BE REMOVED FOR ANY REASON OTHER THAN REPLACEMENT. THE PRESSURE RELIEF VALVE SHOULD ONLY BE REPLACED BY A QUALIFIED SERVICE TECHNICIAN.**

# PLUMBING SYSTEM

## Aqua Go COMFORT PLUS MODELS



- **ECO MODE:** The water heater is running in energy saving mode. Propane gas is used to prevent freezing. The temperature in the water heater is automatically kept above 41°F (5°C). Water temperature coming out of the fixtures is approximately 120°F (49°C). When the water heater is running in ECO MODE, a yellow LED (3) will be lit in the middle of the rotary dial control switch inside the RV.
- **COMFORT MODE:** The appliance is running in a mode that provides rapid availability of hot water. Water temperature at the fixtures is 120°F (49°C).
- System is operating in Stand By Heat, which keeps water temperature in the appliance at 102°F (39°C). While running in COMFORT MODE the yellow status LED (3) on the rotary dial will be lit.
- When the power switch is OFF, the appliance is not running in any operating mode. Yellow status LED (3) on the rotary dial is NOT lit.
- **ANTIFREEZE: (Snowflake / Lightning bolt)** Prevention of freezing using 12VDC electricity. If the accessory electric antifreeze kit is installed, and the appliance switched ON, the temperature in the water heater is automatically held above 41°F (5°C). During operation the yellow status LED (3) is lit.
- **CLEAN: (Decalcification)** This mode is only available on the Aqua Go COMFORT or COMFORT PLUS models. For safety reasons after 30 seconds the decalcification process cannot be stopped until the system has been rinsed (Refer to *Decalcification and Rinsing the System*).



Comfort / Plus Power Switch

### Draining the Aqua Go Water Heater

**CAUTION** (See page 72)

The Aqua Go water heater does not have a conventional drain plug. Instead it includes a “drain chute”.

- Water heater power should be OFF, water pump OFF, and fixtures open to relieve pressure on the plumbing system. **DO NOT DRAIN THE WATER HEATER IF IT IS HOT OR UNDER PRESSURE!**
- Open the water heater exterior door to the “service” position hanging by the straps.
- Open the drain chute by pushing UP on the black button above the yellow label on the left side of the water heater (A). This releases the drain chute.



## NOTE

If the inlet filter is difficult to re-install, use a small amount of soap on the O-rings. NEVER USE GREASE as the O-rings are not resistant to grease.

- Push the chute all the way open which will dump water out of the water heater away from the side of your RV. Water heater contains approximately 1.5 liters of water.
- Drain all the water out of the water heater.
- The water inlet filter is located inside the drain chute (B). The filter will pull out of the opening in the drain chute. Rinse it with clean water, inspect O-rings for cracks.
- To close the drain chute, push it up until it latches back into place. You will hear an audible “click” when the chute engages.

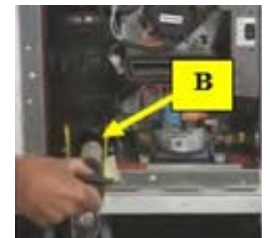

### Winterization

Freezing of the water heater and its plumbing components will result in severe damage not covered by warranty. Follow these recommendations if the unit is to be stored in a freezing environment for long periods of time. At the start of the winter season or before traveling to a location where freezing conditions are likely, the unit must be winterized.

- To winterize the Aqua Go water heater, drain the water out of the water heater using the drain chute.
- Set the RV plumbing bypass valves so no water or antifreeze will enter the water heater.
- Winterize the RV water lines with antifreeze as normal (Refer to *Winterizing the Plumbing System*).
- Do not insert the water inlet filter or heating cartridge into the appliance during winter if the appliance is not used.
- Close the EZ Drain Lever and the access door.



Water Inlet Filter

## NOTE

Using air pressure to blow out the Aqua Go water heater is NOT recommended and may damage the appliance.

## Decalcification

### BASIC MODEL

Lime scale occurs as a result of precipitation from “hard” water. The appliance must be decalcified regularly depending on water hardness and hot water consumption. Decalcification must be done through your RV dealer. Specialized equipment is required and cannot be easily accomplished by the owner.

### COMFORT and COMFORT PLUS MODELS

Models with the interior rotary control dial have a “CLEAN” setting available. These models also include a built in water consumption meter that will light the yellow LED (on the rotary dial) when decalcification is required. This LED will go out briefly every 7 seconds indicating decalcification is required.

Refer to the water heater manufacturer’s instructions included in your warranty packet for additional safety and operating instructions.

### SUBURBAN ON-DEMAND WATER HEATER (IF EQUIPPED)

The ST-42 / ST-60 Suburban On-Demand Water Heater provides a continuous supply of hot water whenever a hot water fixture is turned on. The system activates when water flow is detected, igniting the burner and modulating output to maintain a consistent temperature.

### Operation

- Starting the Water Heater:
  - Ensure the gas supply is turned on.
  - Power on the water heater via the User Control Panel.
  - Open a hot water faucet to initiate heating.
  - The burner will ignite within ~7 seconds, and hot water will flow after residual cold water clears from the lines.
- Temperature Control:
  - Default setting: 113°F (45°C).
  - Adjustable range: 95°F (35°C) – 131°F (55°C).
  - A child lock prevents exceeding 122°F (50°C); hold the up arrow for 5 seconds to disable.
- Shutdown Procedure:
  - Press the power button on the User Control Panel.
  - Turn off electrical power and gas supply if storing the RV or not using the heater.

### Maintenance & Troubleshooting

- Routine Checks: Inspect vents for obstructions and soot buildup, which indicates incomplete combustion.
- Winterization: Use compressed air or RV antifreeze to prevent freezing.
- Descaling: Flush the heat exchanger yearly with an approved descaling solution.
- System Lockout: If the unit fails to ignite three times, reset by turning the unit off and on.

### Safety Precautions

- Gas Leak Warning: If you smell gas, evacuate the RV, shut off the gas supply, avoid electrical switches, and contact a qualified technician or fire department.
- Flammable Materials: Do not store or use gasoline or flammable liquids near the water heater.

- Burn & Scald Prevention: The factory-set water temperature is 113°F (45°C). Always check water temperature before use, especially for children, elderly, or disabled persons.
- Ventilation: Ensure proper venting; do not install add-ons that obstruct airflow.
- Winterization: Drain or use RV antifreeze to protect the unit from freezing temperatures when storing the RV.

### Safety Features

- Flame Out Protection: Shuts off gas if the flame is extinguished.
- Voltage & Overcurrent Protection: Operates only within 10VDC – 17VDC range; internal fuse prevents damage from electrical faults.
- Freeze Protection: Activates burner when temperatures drop below 41°F (5°C) (gas and power must be on).
- Pressure Relief Valve: Prevents overpressure damage.

For service or parts, contact a certified technician or refer to the warranty information provided with your RV. <https://library.suburbanrv.com/>

### WATER PURIFICATION SYSTEM

**⚠ CAUTION ⚠** (See page 72)

The canister filter is the primary filter used for the complete water system. If the water supply has not been used for some time, allow the water to flow for several minutes to flush the system.

**Filters should be replaced at the beginning of each camping season or if they have come into contact with contaminated water.** When not in use, the water filter cartridge should be stored out of freezing temperatures. RV antifreeze will damage the water filter cartridge. Filter locations will vary by model. They are typically located in a compartment behind the utility center (if so equipped).

### To Replace Canister Filter Cartridge

- Turn off water supply using two valves located on the water lines on each side of the canister. Water pump should be OFF.
- Place drip pan below filter housing to catch any : ...
- Press the red button on top of the filter housing to release pressure.
- Using a spanner wrench, rotate the filter housing. Unscrew the housing completely, dump water out and remove the filter (dispose of the old filter properly).
- Clean the inside of the filter housing with mild detergent. Thoroughly rinse and wipe clean.
- Remove the O-ring from the groove in the housing and wipe clean. Coat with petroleum jelly.
- Replace the O-ring in the groove, making sure it is properly seated.
- Install the new filter cartridge.
- Replace the canister housing (hand tighten is normally sufficient).
- Turn on the water supply, turn the pump ON, open a faucet and check for leaks. Turn the pump OFF afterwards.

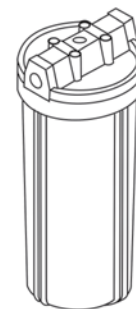

Filter Housing

## NOTE

There is no bypass feature on a canister style water filter. The water filter must be removed before sanitizing or winterizing the RV.

Each new recreational vehicle is winterized with RV antifreeze before it is shipped to the dealer. To use the water purification system, full system canister water lines need to be flushed of antifreeze and then the filter installed in the canister before use.

Refer to the manufacturer's owner's manual and the label on the water filter cartridge for further information.

## OUTSIDE SHOWER

A handheld shower assembly with both hot and cold water is included for use outside of your recreational vehicle. It may be located in a separate outside shower compartment or at the utility center (if so equipped).

1. Be sure the water heater is ON and had sufficient time to heat the water.
2. If dry camping, be sure the 12-volt water pump is ON.
3. Remove the handheld shower from its holder.
4. Turn ON the hot and cold faucet knobs, and adjust the water temperature as desired.
5. To activate the handheld shower turn ON the sprayer head attachment (some models).

To turn off the water, always close the hot/cold control (faucet) knobs. The lever on the shower head will not completely stop the flow of water; this is intentional to allow for draining. After the water has been allowed to drain from the shower head, return it to the outside shower storage. Any remaining water in the shower hose will drip or run out; this is not a leak but performs as intended. If you are dry camping, turn the water pump OFF.

Turning off the water with the shower head lever can also create a condition where the hot and cold water will mix through the outside shower faucet, thereby reducing the temperature of the hot water. It can appear as though the hot water heater is not working properly.

## NOTE

- The shower head may be removed from the hose so that it will drain faster. If you remove the shower head, be sure to reassemble it prior to storage.
- When putting the shower assembly back into the storage compartment, make sure the hose is not pinched or the shower head is positioned in a way it can be damaged.

## FAUCETS

The bathroom, kitchen and outside shower faucets operate much the same way as the faucets in your home. Make sure there is sufficient water available and the 12-volt water pump is turned ON before operating.

## NOTE

There may be air in the water plumbing lines which needs to be bled out before a steady stream of water comes from the faucet.

## BATHROOM TUB / SHOWER

**⚠ WARNING ⚠** (See page 70)

Keep the water heater and holding tank capacities in mind when using the fresh water system. The used water will drain into the grey water holding tank.

- Be sure the water heater is ON and had sufficient time to heat the water.
- If dry camping, be sure your 12-volt water pump is ON.

Unlike your home, the recreational vehicle does not contain a water pressure balance valve. If someone is using the shower, it is recommended that the fresh water system **NOT BE USED** until they are finished.

The shower faucet may include a vacuum breaker for the shower. There are two purposes for this breaker:

- To prevent siphoning water through the hose from another fixture.
- To prevent water from being retained in the hose.

The showerhead DOES NOT have a complete shut-off valve (the complete shut-off is at the faucet). The showerhead may drip slightly in the OFF position after use; this is normal and does not indicate a leak or defect.

### Maintenance

Refer the manufacturer's user guide or label instructions for detailed cleaning information. The tub/shower walls are made of ABS plastic material. Use a mild detergent soap and warm water to clean. Do not use gritty or abrasive particle soaps or scouring compound to clean ABS plastic. Avoid using "Citrus" or biodegradable cleaners which contain "D-Limonene." They will damage plastic materials.

## SHOWER MISER

**⚠ CAUTION ⚠** (See page 72)

The Shower Miser is a device attached to your inside shower that helps to conserve water especially when you are dry camping and are restricted to the amount of water available in your fresh water tank and don't have ready access to a water supply.

The device is installed on the incoming water line for the shower and will circulate water from your water heater, back into your fresh water tank until the water in the shower comes up to temperature. This prevents needlessly dumping your limited supply of water waiting for the shower to heat up.

### Operation

The device consists of a small valve and a blue plastic "dot" below the shower handle.

When the small valve (on the Shower Miser) is in the closed (OFF) position, wasted cold water is directed to the fresh water tank. No water will flow through the shower head. The blue "dot" will be dark blue when cold water is running through the shower plumbing. When the water is up to temperature, the blue "dot" will change color from a dark blue to white which indicates the water flowing into the shower is now hot. Turn the small valve the opposite direction (to ON) and turn on the shower valve so water flows out of the showerhead. The color change is obvious so there is no question when the water is at a comfortable temperature.

As you shower, the small Shower Miser valve can be turned OFF while you use the soap, so water will divert into the fresh water tank instead of down the drain, and it keeps the water up to temperature, so when you turn the Shower Miser valve back ON, you immediately have hot water to rinse with.

The Shower Miser system may vary depending on your model.

## Filling The Fresh Water Tank

Shower Miser will also fill the fresh water tank from inside the RV when hooked up to a pressurized water source.

- A pressurized water source must be connected to the RV and turned ON.
- Check the tank monitor to see how much fresh water is in the tank.
- Turn the lever on the Shower Miser to bypass the showerhead (OFF).
- Turn the cold water shower valve fully ON.
- Watch the tank monitor as the fresh water tank fills.
- When tank is full, turn the cold water shower valve OFF.

## BLACK/GREY WATER SYSTEM AND TANKS

Water from the sinks and shower flows into the gray water (or wastewater) holding tank. Water from the toilet will flow into the black water (or sewage) holding tank (see *Black/Grey Water Holding Tanks*).

### Drain Pipes with P-Trap (if so equipped)

The drain pipes may be equipped with a “P-trap” installed to help prevent odors from escaping into the RV. During travel, water from the P-traps may spill and permit odors into the RV. By adding water and using a RV approved deodorizing agent you will dissolve the contents faster and will keep the drain lines and tanks clean and free flowing. These chemicals are available at an RV supply store or your dealer.

### Drain Pipes with Dry Sealing Valve (if so equipped)

Your RV may be equipped with a dry sealing valve that prevents the escape of odors from your waste system and eliminates the need for P-traps. Should the RV drain piping system become clogged, it is important that the dry valve be removed before passing a mechanical cleanout tool through the piping to open the drain. Passing a cleanout tool through the waterless valve may cause damage to the internal seal that may potentially allow sewer gases to escape into the RV interior. The waterless trap can be unscrewed from the water lines.



Waterless Trap

A label has been placed near the location of the waste valve that reads as follows:

REMOVE WATERLESS TRAP BEFORE  
USING MECHANICAL DRAIN CLEANING DEVICES

## Sewer Hose Storage

Depending on your RV model, the sewer drain hose may be stored in an exterior compartment marked “Sewer Hose” or it may be located in the hollow square tube bumper. The bumper has removable plastic end caps, and the hose slides inside the hollow bumper.

## Vents

Vent pipes and vents release air from the grey and black water holding tanks. On most models the exterior vent cap is attached to the roof and must be kept clear of obstructions to perform as intended. On some models, the vent pipe may be part of the drainage system referred to as a “wet vent” where water flows downward as air flows upward in the same pipe.

Some models are equipped with a side vent system. On these models this label will be next to the termination valve. This label should not be removed from your recreation vehicle.

### CAUTION

Keep drain valve closed to minimize the presence of sewer gases. Sewer gases may be present when RV is connected to campground sewage hookup. May lead to illness or personal injury.

## Black/Grey Water Holding Tanks

**WARNING** **CAUTION** (See page 70) & (See page 72)

Dump the gray and black water holding tanks before traveling to avoid carrying unnecessary weight. The weight of the holding tank contents is not calculated into the RV cargo carrying capacity. Traveling with full holding tank(s) could cause you to exceed the individual tire ratings and/or the RV GAWR or RV GVWR. Potential damage to suspension components, such as springs, tires and axles, could result.

If you are dry camping and cannot immediately empty your holding tanks, reduce your vehicle speed until you reach a dumping station. When connected to the sewer drain line at a campground, keep the black tank drain valve closed until the holding tank is at least  $\frac{3}{4}$  full. This will provide sufficient water to assist in complete draining of the black water holding tank. Repeat as needed.

Before using the recreation vehicle, or after dumping the grey and black water holding tanks, always add the proper amount of deodorant to the black water tank to prevent odors and help break down holding tank contents (unless winterizing). Follow the deodorant bottle or package instructions. Driving to a disposal site will normally loosen any accumulated waste debris or solids from the sides of the holding tanks.

## BLACK AND GREY TANK DRAINS

There are labels on the exterior of the recreation vehicle indicating the location of the grey and black tank drains (also called dump valves). Depending on your model, you may have one or two valves. With one valve, the gray and black tank will release contents simultaneously. With the 2-valve set up, it is recommended that you release the black tank first, followed by the grey tank. This will help rinse and debris from the outlet and sewer hose.



Black / Grey Tank Drain Valve

1. To make drainage easier, level the RV.

2. Remove the sewer hose housing dust cap and attach the sewer hose (customer supplied).
3. Place the end of the sewer hose into the approved dump station.
4. Open the black tank dump valve (depending on your model the valve may be located under the RV, or on the utility center). Close the dump valve when the black water holding tank is empty.
5. Open the grey tank dump valve (depending on your model the valve may be located under the RV or on the utility center). Close the dump valve when the grey holding tank is empty.
6. Remove, clean and store the sewer hose.
7. Close the sewer hose housing dust cap.

You can locate dump stations throughout the United States and Canada in Woodall's, Rand McNally Camp Guide, Good Sam Camp Guide, KOA Campgrounds Camp Guide and various other publications. Some fuel stations also have dump stations. Please contact your RV dealer for assistance in the purchase and installation of a sewer hose or sewer hose extension (if needed).

## Sewage (black) tank preparation

**⚠ WARNING ⚠** (See page 71)

1. Release one to two quarts (1 or 2 liters) of water into the toilet bowl.
2. Follow the directions on your RV-approved toilet chemical bottle (customer supplied) and put the recommended quantity of holding tank chemical into the toilet bowl.
3. Flush the toilet and allow at least two gallons (8 liters) of water to flow into the holding tank.

## Waste (grey) holding tank preparation

No special preparation is required, however, placing a small quantity of chemicals into this tank, such as baking soda or an approved RV chemical, will reduce odors from food particles in the system.

## Cleaning and Maintenance

The toilet should be cleaned regularly for maximum sanitation and operational efficiency. Use only RV approved chemicals. Do not use chlorine (undiluted) or caustic chemicals, such as laundry bleach or drain opening types, in the toilet system. These products damage the seals in toilets and dump valves.

## BLACK TANK FLUSH

**⚠ WARNING ⚠** **⚠ CAUTION ⚠** (See page 71)

The black tank flush (no fuss flush) inlet is typically located on the utility center panel (if so equipped) labeled as "Tank Flush". For models not equipped with a utility center, the inlet is located on the side of the recreation vehicle. The location may vary depending on your model. Attach a garden hose (connected to a pressurized fresh water source) to the black tank flush inlet. The water goes directly into the black water holding tank sprayer connection, allowing you to remove debris and preventing accumulation. A check valve is incorporated in the plumbing lines to prevent back flow. Flush the black water tank each time the grey and black water holding tanks are dumped or as needed.

## NOTE

- Utility center (if so equipped) valve positions do not affect the tank flush function. It does not matter where they are positioned when operating the tank flush.
- To help insure debris does not clog the tank sprayer orifices, use "TANK FLUSH" every time the waste holding tank is emptied.

1. Dump the black water tank (see *Gray Tank Drain & Black Tank Drain*) and leave the black tank drain valve open.
2. Connect a garden hose from the water supply source to the black tank flush.
3. With the water source turned ON, flush the black water holding tank until the water running out of the black tank drain valve is clear (not discolored or cloudy).
4. Disconnect the garden hose and close the black tank drain valve. Fasten the sewer hose housing dust cap back on the tank flush inlet.

## Winterize the BLACK TANK FLUSH

1. Black tank should be empty prior to winterizing.
2. Rinse the black tank prior to blowing it out with air.
3. Attach the 4" sewer hose to the dump connector under the RV.
4. Open the waste gate valve for the black tank (under the RV).

## NOTE

If the RV has a macerator system, you need to open the bypass valve for the macerator under the RV. This will allow the black tank to drain through the 4" sewer hose.

5. Attach a garden hose to the TANK FLUSH inlet at the utility center.
6. Attach the other end of the hose to a pressurized water source. Turn water on.
7. Flush tank until water appears clear in 4" sewer hose.
8. Turn off water, disconnect the hose from faucet, disconnect hose from tank flush.
9. Connect the blowout plug to the Black Tank Flush inlet at the utility center panel.
10. Colored valves have no effect on the black tank flush inlet.
11. Connect the air hose to the blowout plug. Set the compressor to **30 PSI maximum**.
12. Open the black tank drain gate valve, macerator bypass valve is open also.
13. Blow air into the flush inlet for 30 to 60 seconds.
14. Disconnect the air hose, compressor and blowout plug.
15. Close the black tank drain gate valve and close the macerator bypass valve.

## Draining the Spray Port

With fixtures and drain valves open in the RV to drain the water lines, connect the blue-coiled hose to the brass quick connect fitting at the Spray Port.



Spray Port

1. Remove the spray nozzle from the other end of the hose.
2. Hold the open end of the hose near the ground and any water in the line should drain out.
3. Disconnect the hose from the fitting, and store in the RV.
4. Close the port cover.

## Winterizing the Spray Port with Antifreeze (if so equipped)

1. As you are putting antifreeze into the water lines, attach the hose to the Spray Port.
2. Have a container close by to capture antifreeze.
3. Pull the trigger on the spray nozzle until antifreeze comes out (into the container).
4. Release the nozzle and disconnect the hose from the port.
5. Rinse out the hose before storing it.

## TANK HEATERS (IF EQUIPPED)

**CAUTION** (See page 72)

Your recreational vehicle may be equipped with heaters for the fresh, gray, black water tanks. The larger tank heaters are 12VDC and attach directly to the tanks. The thermostat controlled tank heaters will cycle on at 44°F (7°C) and off at 64°F (18°C). All of the heaters are controlled by a single ON/OFF button that is typically located on the Command Center Panel or Firefly Touchscreen. The button lights up when 'ON' and controls the heater circuit.

### The tank heater button should be turned ON:

- When liquid is present in the holding tanks and the outside temperature approaches and maintains freezing conditions 35°F (2°C) or colder.

### The tank heater button should be turned OFF:

- When there is NO liquid present (tanks are empty).
- When dumping the black and gray holding tanks and the drain pipes.
- When fresh water tank and supply lines are empty or being drained for storage.
- When the recreation vehicle is connected to city sewer and the gate valves are open.

## NOTE

Free draining is never recommended, especially in cold weather use.

- When ambient temperatures rise and remain above freezing.

No maintenance on the heaters is required, only a periodic inspection for loose wires, damage, etc. For additional detailed information, refer to the tank heater manufacturer's user guide.

## TOILET

**CAUTION** (See page 71)

Prior to using the sanitation system, it is strongly recommended to flush the toilet several times to release sufficient water into the holding tank. Generally, more water is required only when flushing solids.

The toilet system will perform better when water is run for ten to fifteen seconds after flushing to ensure that the waste will proceed to the bottom of the tank.

If there is not a sufficient amount of water used during flushing, the waste materials may not evacuate properly from the drain line to the tank. Clogged tanks and pipes could eventually occur. For added convenience and better sanitation system performance, it is advisable to always have four to six inches (10 - 15 cm) of water in the toilet. It is important to add enough water to prevent solid waste buildup. The following guidelines will help to prevent solid waste buildup.

### Sewage (black) tank preparation

1. Release one to two quarts (1 or 2 liters) of water into the toilet bowl.
2. Follow the directions on your (approved RV) toilet chemical bottle (customer supplied), by placing the recommended quantity of holding tank chemical into the toilet bowl.
3. Flush the toilet and allow at least two gallons (8 liters) of water to flow into the holding tank.

### Cleaning & Maintenance

The toilet should be cleaned regularly for maximum sanitation and operational efficiency.

For detailed information refer to the manufacturer's operator manual.





### **TRUMA WATER HEATER (See page 63)**

#### **Danger of combustion, personal injury and damage to the RV!**

- Keep the area around the appliance free from combustible materials, gasoline and other flammable liquids or vapors.
- Switch **OFF** the appliance and gas supply:
  - If you smell gas
  - If anything appears out of the ordinary
  - If you move the RV
  - Before entering a gas station
  - Before entering a tunnel

#### **Danger of over-temperature and toxic exhaust gases!**

- Use with LP gas (propane) only. Butane or any mixtures containing more than 10% butane must not be used.
- Keep the air inlet and exhaust gas outlet free of obstructions. Do not lean any objects against the water heater access door or place any foreign objects within 2 feet (61cm) of the access door.

### **WINTERIZATION: COMPARTMENT UTILITY (See page 60)**

- Automotive antifreeze (ethylene glycol) and windshield washer antifreeze (methanol) are poisonous. Never use these products in your fresh water system. These products are harmful and may be fatal if swallowed.
- Never apply air pressure to the water system with any of the valves in the closed position. Air pressure applied to a closed valve, faucet or low point drain could potentially damage the seals and cause water leaks. If you have questions, consult with your RV dealer. Using RV antifreeze is the preferred method of winterization.

### **WATER HEATER - TANK (See page 61)**

- Hydrogen gas may result if you have not used the water heater for two weeks or more. **HYDROGEN GAS IS EXTREMELY FLAMMABLE.** To reduce the risk of injury under these conditions, open the hot water faucet for several minutes at the kitchen sink before you use any electrical appliance connected to the hot water system. If hydrogen is present, you may hear what sounds like air escaping through the pipe as the water begins to flow. Hydrogen gas may be present even after water has been drained from the water heater tank. Open the faucet at the sink and allow the system to vent for five to ten minutes. Do not smoke or have any open flame near the open faucet while venting. On DSI water heater models, make sure the switch is OFF.
- Do not alter the operation or change the design/construction of your water heater. For your safety, only factory authorized parts should be used on your water heater. Accessories marketed for recreation vehicles, such as an "add-on" electric heating elements, are not recommended by the manufacturer. Such items are not approved to be installed and could create an unsafe condition and will void all warranties.
- **If you smell propane gas then STOP!** and follow the procedures listed in the *Propane System section* before attempting to operate the water heater.

### **BLACK/GREY WATER HOLDING TANKS (See page 67)**

Never travel with full black or grey water holding tanks. Depending on the location of the tank(s) it can affect your tow vehicle handling characteristics.

### **FRESH WATER SYSTEM (See page 55)**

- DO NOT drink water deemed microbiologically unsafe or of unknown quality.
- Avoid traveling with full fresh, black or grey water holding tanks. The weight of holding tank contents is not calculated into the RV cargo carrying capacity. Traveling with full tanks could cause you to exceed the individual tire ratings and/or the RV GAWR or GVWR. Traveling with full tanks can also affect your vehicle handling characteristics.

### **BATHROOM TUB/SHOWER (See page 66)**

Water temperatures over 125°F (49°C) can cause severe burns instantly therefore, be careful when using hot water. **Always test the water temperature before showering or washing.**

### **PRESSURE AND TEMP RELEASE VALVE ((See page 62)**

Do not place a valve between the pressure and temperature (P&T) valve and the tank. Do not remove or plug the relief valve under any circumstances.

 **WARNING** 

**PRESSURE TEMPERATURE RELIEF VALVE (See page 63)**

**SCALDING INJURY – EXPLOSION**

- Valve is not serviceable; if defective it must be replaced.
- Tampering with the valve will result in scalding injury. Do not place a plug or reducing coupling on the outlet part of the valve. If you use a discharge line allow complete drainage for both valve and line.
- Tampering with the valve will void the warranty.

**SEWAGE TANK PREPARATION (See page 68)**

It is important to add enough water to prevent solid waste buildup. Follow the directions listed below and in the manufacturer’s operator manual.

**BLACK TANK FLUSH (See page 68)**

Do not use the same hose to fill your fresh (potable) water tank that is used for the black tank flush.

**TRUMA® COMBI DIESEL 2 in 1 SYSTEM (See page 71)**

**Danger of combustion, personal injury and damage to the RV!**

- Keep the area around the appliance free from combustible materials, gasoline and other flammable liquids or vapors.
- Switch OFF the appliance and gas supply:
  - If you smell gas
  - If anything appears out of the ordinary
  - If you move the RV
  - Before entering a gas station
  - Before entering a tunnel

**Danger of over-temperature and toxic exhaust gases!**

- Use with LP gas (propane) only. Butane or any mixtures containing more than 10% butane must not be used.
- Keep the area in front of the warm air outlets free of combustible or heat-sensitive materials. Do not put any material into the warm air outlets.
- Check that furnace vent (and air intake) terminal(s) are not obstructed in any way during all seasons.
- Danger of hot surfaces. The temperature of the exhaust gases can reach 320 °F (160 °C). Do not touch the area around the wall cowl and do not lean any objects against the wall cowl or the RV.
- Shut OFF the Combi furnace when refueling or pumping gas.

 **CAUTION** 

**PLUMBING SYSTEM CAUTION**

**FRESH WATER HOLDING TANK (See page 55)**

- Do not cap, block or modify the fresh water tank overflow tubes in any way. Enough water pressure can build up during the filling process to damage the plumbing system if the overflow tubes are obstructed.
- Be careful not to overfill the fresh water holding tank. It can pressurize the tank, causing leakage and water damage and void the warranty. DO NOT leave the tank unattended while filling.

**TOILET (See page 69)**

- It is important to prevent solid waste buildup. Follow the toilet manufacturer’s recommended instructions each time after emptying the black water holding tank.
- To help prevent toilet blockage, always use RV grade single-ply toilet paper. Do not flush paper towels, diapers, sanitary napkins or other foreign objects down the toilet. To avoid damage to the toilet, only flush organic material and toilet paper
- Do not use chlorine (undiluted) or caustic chemicals, such as laundry bleach or drain opening types, in the toilet system. These products damage the seals in toilets and dump valves.

**TRUMA WATER HEATER (See page 63)**

- Water in pipes, faucets and appliances could freeze. Considerable damage may result.
- Before you fill water into appliances and parts that transport water, you must heat the installation area sufficiently so that water cannot freeze.



### **BLACK/GREY WATER HOLDING TANKS (See page 67)**

- Never leave the black tank drain in the open position continuously when connected to the campground sewer system. Leaving the drain open will allow the liquid to drain out increasing the potential for a blockage in the tank. Keeping the drain in the closed position will prevent debris from accumulating in the tank.
- Do not add automotive antifreeze or caustic chemicals, such as laundry detergents, into the holding tanks. Although these products may have a deodorizing effect, they may damage the plastic and rubber parts of the plumbing system or the components

### **WATER PURIFICATION SYSTEM (See page 65)**

- Do not allow water in the canister housing to freeze.
- Remove the filter before using anti-freeze to winterize the system or chlorine solution to sanitize the system.
- Flush canister housing thoroughly before it is put back into service after winterizing or sanitizing.
- For best results replace filter every 6-12 months.
- Do not use carbon cartridges where water is microbiologically unsafe or of unknown quality.
- Maximum operating pressure is 125 psi (8.75 bar).
- Maximum water temperature is 125° F (52° C).

### **BLACK TANK FLUSH (See page 68)**

- The black tank drain valve must be OPEN any time there is a hose (water supply) connected to the black tank flush.
- Do not leave any hose (water supply) connected to the black tank flush when it is not in use.

### **WINTERIZE THE MACERATOR SYSTEM (See page 61)**

Water can accumulate in the flexible hose and dump connector of the macerator system. Antifreeze must be added to the macerator system to prevent freeze damage.

### **WINTERIZATION: COMPARTMENT UTILITY (See page 60)**

If the motor home is going to be stored in a non-temperature controlled environment with a risk of temperatures reaching 32°F (0°C) or lower, the demand (power) system with RV antifreeze *must* be used in the motor home plumbing system as directed in this manual. This includes appliances such as the washer, dishwasher and the refrigerator

### **TRUMA® COMBI DIESEL 2 in 1 SYSTEM (See page 71)**

#### **Damage to the Combi furnace caused by freezing!**

- The Combi furnace does not have a frost-protection function. If the heating is not used and there is a risk of freezing, all water must be drained from the water container
- Water in pipes, faucets and appliances could freeze. Considerable damage may result.
- Before you fill water into appliances and parts that transport water, you must heat the installation area sufficiently so that water cannot freeze.
- No warranty claims are accepted by the manufacturer of the Combi furnace for frost/freeze damage

### **WATER PRESSURE REGULATOR (See page 55)**

A water pressure regulator is recommended to prevent damage to the plumbing system or components. To prevent damage when using the city water connection, a 45 lb. (315 KPa) rated water pressure regulator is recommended.

### **SHOWER MISER (See page 72)**

When using the Shower Miser with pressurized city water hookups the fresh water tank can overflow on to the ground.

### **DRAINING THE AQUA GO (See page 64)**

When the drain chute is folded out, it protrudes past the sidewall of the RV.

- When walking past or stooping down, make sure you and others have sufficient clearance to prevent injuries.
- Never actuate the Easy Drain Lever as long as the appliance is under water pressure or is still hot.
- Never put fingers between the Easy Drain Lever and the latch.

### **TANK HEATERS (See page 69)**

The red light on the switch does not necessarily indicate that ALL heaters are operating; it is only a warning that the heater circuit is ON.

# SECTION 9: HEATING & COOLING



## AIR CONDITIONER

Cooled air enters the RV through the grill. Make sure you have sufficient power available before operating the air conditioner. Do not operate the air conditioner without the return air filter. Operating the system without the filter allows the lint and dirt that is normally stopped by the filter to accumulate on the cooling coil of the air conditioner. This also will lead to a loss of air volume, possible equipment damage and an expensive cleaning process.

### Roof Mount

A special foam gasket is placed between the roof material and the sub frame of the air conditioner to guard against water leakage. The air conditioner is subjected to wind pressures along with motor vibration during normal operation. Inspect the mounting bolts for tightness to ensure there is no leakage or looseness at least annually. Re-tighten bolts when they are loose. **DO NOT** over tighten these bolts as it may damage this gasket. The air conditioner gasket is a wearable part that eventually will need to be replaced. To gain access to the bolts, remove the filtered panel cover on central air systems or the entire air box on non-central air conditioners.

### Heat pump operation (if so equipped)

**⚠ CAUTION ⚠** (See page 75)

Set the thermostat for either electric or gas heat. On the electric setting, the heat pump will become the primary heat source as long as the interior temperature of the RV has not dropped 5° below the thermostat set point. If this occurs, the thermostat will automatically activate your gas furnace.

The furnace will continue as the heat source until the thermostat set point has been satisfied. At that point, the heat pump will again become the primary heat source.

For RV models with a touch screen system, the heating cooling controls are included on the touch screen selectable screens.

**For additional information** refer to the manufacturer's owner's manual included in your warranty packet or consult your dealer.

### FIREPLACE (IF SO EQUIPPED)

Your recreational vehicle may include an electric fireplace insert. For detailed operating and safety information, refer to the manufacturer's user guide included in your warranty packet.

### FURNACE (IF EQUIPPED)

**⚠ WARNING ⚠** (See page 75)

The furnace installed in your recreation vehicle is controlled by a 12-volt DC thermostat. Depending on your model, there may be up to two thermostats enabling you to control the temperature to your comfort level. The furnace requires both 12-volt power and propane gas for full operation. Make sure you have sufficient power available before operating your furnace.

A qualified RV technician should perform all furnace maintenance at least once a year (more often depending on furnace usage). Never attempt to repair the furnace yourself.

#### Ducting & Return Air

All heat discharges, registers and return air grills must be free and clear of obstructions. This includes all closeable registers that are intended to reduce airflow, do not shut it off completely.

### NOTE

For RV models with touch screens, the furnace controls may be included on the selectable menu screens of the touch screen.

### TRUMA® COMBI DIESEL 2 in 1 SYSTEM (IF EQUIPPED)

**⚠ WARNING ⚠** **⚠ CAUTION ⚠** (See page 75) & (See page 75)

Your recreation vehicle may be equipped a Truma® Combi furnace with supplementary indirect water heating. Refer to the manufacturer's owner manual, for important operating and safety information.

### POWER ROOF VENT

The 12-volt DC powered roof vent allows fresh air to circulate through the recreational vehicle. Do not leave the attic fan open when the recreational vehicle is stored or unattended for long periods. High winds, other unusual conditions or obstructions may prevent the dome from closing; the resulting leakage could cause non-warrantable damage.

To use your fan most effectively, close all vents and slightly open a window on a shaded side of your recreation vehicle. You are directing the air flow by opening a window.

The roof vent is controlled by either a switch or touch screen.

**For additional safety and operating information, refer to the manufacturer's manual.**

### NOTE

For RV models with touch screens, the furnace controls may be included on the selectable menu screens of the touch screen.

**FURNACE (See page 74)**

- The furnace should be inspected periodically (monthly during the heating season) for presence of soot on the vent. Soot is formed whenever combustion is incomplete. This is a visual warning that the furnace is operating in an unsafe manner. If soot is observed on the vent, immediately shut the furnace OFF and contact a qualified service agency. Operating the furnace under this condition could lead to serious property damage, personal injury or loss of life.
- To ensure your personal safety, do not obstruct or alter the furnace in any manner. Do not install screens over the vent for any reason. Screens will become restricted and cause unsafe furnace operation. For your safety, only the manufacturer's factory authorized parts should be used on your furnace.

**TRUMA® COMBI DIESEL 2 in 1 SYSTEM (See page 74)****Danger of combustion, personal injury and damage to the RV!**

- Keep the area around the appliance free from combustible materials, gasoline and other flammable liquids or vapors.
- Switch OFF the appliance and gas supply:
  - If you smell gas
  - If anything appears out of the ordinary
  - If you move the RV
  - Before entering a gas station
  - Before entering a tunnel

**Danger of over-temperature and toxic exhaust gases!**

- Use with LP gas (propane) only. Butane or any mixtures containing more than 10% butane must not be used.
- Keep the area in front of the warm air outlets free of combustible or heat-sensitive materials. Do not put any material into the warm air outlets.
- Check that furnace vent (and air intake) terminal(s) are not obstructed in any way during all seasons.
- Danger of hot surfaces. The temperature of the exhaust gases can reach 320 °F (160 °C). Do not touch the area around the wall cowl and do not lean any objects against the wall cowl or the RV.
- Shut OFF the Combi furnace when refueling or pumping gas.

**HEAT PUMP (See page 73)**

Do not operate the heat pump for extended periods of time without the filter installed. Lint, grease, dirt, etc. that are normally stopped by the filter are now accumulating in the cooling coil. This leads to loss of air volume, icing up of the cooling coil, and could result in serious damage to the operating components of the heat pump.

**TRUMA® COMBI DIESEL 2 in 1 SYSTEM (See page 74)****Damage to the Combi furnace caused by freezing!**

- The Combi furnace does not have a frost-protection function. If the heating is not used and there is a risk of freezing, all water must be drained from the water container
- Water in pipes, faucets and appliances could freeze. Considerable damage may result.
- Before you fill water into appliances and parts that transport water, you must heat the installation area sufficiently so that water cannot freeze.
- No warranty claims are accepted by the manufacturer of the Combi furnace for frost/freeze damage

# SECTION 10: APPLIANCES



## COOKING SAFETY

### In Case Of a Grease Fire

**⚠ WARNING ⚠** (See page 79)

Grease is flammable. Never allow grease to collect around top burners or on the cook top surface. Wipe up spills immediately. Refer to *Section 2 – Safety Precautions*, for fire safety and fire extinguisher information.

### Cooking With Propane (If Equipped)

See the *Propane System* section for important safety instructions. Refer to the manufacturer's owner's manual for detailed operating and safety instructions for all propane appliances.

## COOKTOPS, RANGE AND OVEN (IF EQUIPPED)

**⚠ WARNING ⚠** **⚠ CAUTION ⚠** (See page 79)

For detailed operating and safety information, refer to the manufacturer's user guide.

### Cleaning instructions

Refer to the manufacturer's user guide included for detailed cleaning instructions.

### General Cleaning

- **To avoid damage and possible burns, be sure the appliance is off and all parts are cool before handling or cleaning.**
- Use care to avoid steam burns if a wet sponge or cloth is used to wipe spills on a hot surface.
- Some cleaners can produce noxious fumes if applied to a hot surface.
- To prevent staining or discoloration, clean appliance after each use.
- If a part is removed, be sure it is correctly replaced.

- If a spillover occurs while cooking, immediately clean the spill from the cooking area while it is hot to prevent a tough cleaning chore later. Using extreme care, wipe spill with a clean, dry towel.

### Kitchen Range and Oven (if so equipped)

## NOTE

To help reduce potential condensation or unwanted cooking odors, turn on the overhead kitchen roof vent or the range hood vent (if so equipped).

To prevent damage, always use the manufacturer's recommended size flat bottom pan(s). Generally, the pan should be large enough to cover the burner, but not be more than one inch larger than the burner grate.

Do not use a broiler pan, griddle or any other large utensil that covers more than one burner at a time. This will create excessive heat that may cause melting, sooting or discoloration.

The use of undersized pans could expose a portion of the heating element to direct contact and may result in ignition of clothing. Proper relationship of pans to burner will improve efficiency.

The propane gas oven must have 12-volt power to operate. **Do not use the oven as a storage area.** If you have any questions, contact your dealer or our customer service department.

### Gas Drop-In Cooktops (if so equipped)

Depending on your model, it may be equipped with either a 2 burner or 3 burner cooktop. The 2 burner match-light cooktop has two 6500 BTU/H burners with control panel.

The 3-burner piezo-igniter cooktop has (1) front 9000 BTU/H burner and two rear 5200 BTU/H burners. The 3 burner cooktop is also equipped with a control panel.

Refer to manufacturer's user guide for detailed operating and cleaning information.

# APPLIANCES

## INDUCTION COOKTOP (IF EQUIPPED)

**⚠ WARNING ⚠** **⚠ CAUTION ⚠** (See page 79)

Induction cooktops are more efficient than gas or electric cooktops. The cooking surface heats through magnetic induction. Cookware for induction cooking should be magnetic (steel or cast iron) and have a flat bottom. Cookware made from aluminum, corning ware, Pyrex, or glass will not work by just placing them on the surface, but can be used if they are placed on top of a magnetic interface disk which will function as a conventional hot plate. Stainless steel cookware may or may not work. If there is a doubt as to whether a certain pan or skillet will work, check it with a magnet. If the magnet clings to it, it will probably work with the induction cooktop; if it doesn't or clings weakly it probably won't work.

Induction cooktops are much safer to use than electric or gas.

- The stovetop stays cool, no burned fingers or hands if you touch the surface.
- Only the cooking vessel gets hot.
- The cooking surface only works when there is a magnetic pan (or interface disk) in place on it. Sensors detect the amount of ferrous material in the area of the magnetic field and if it is not the size of a small pan it won't turn on.
- Induction cooktops will not heat up the kitchen.
- Very rapid temperature increases can be achieved and very fine adjustments can be made.

Refer to manufacturer's manual for detailed safety, operating and cleaning instructions.

## MICROWAVE

**⚠ WARNING ⚠** **⚠ CAUTION ⚠** (See page 79)

For details on operation, cleaning and safety information, refer to the manufacturer's user guide.

### General Cleaning Microwave and Convection Microwave

**IMPORTANT:** Before cleaning, make sure all controls are off and the microwave oven is cool. Always follow label instructions on cleaning products.

To avoid damage to the microwave oven caused by arcing due to soil buildup keep cavity, microwave inlet cover, cooking rack supports, and area where the door touches the frame clean.

Clean with mild soap, water and a soft cloth or sponge, or as indicated below.

- Grease filters: mild soap and water or dishwasher.
- Door and exterior: mild soap and water, or glass cleaner applied to paper towel.
- Control panel: sponge or soft cloth and water.
- Stainless steel (on some models): mild soap and water, then rinse with clean water and dry with soft cloth, or use stainless steel cleaner.
- Turntable: mild soap and water or dishwasher.
- Rack(s): mild soap, water and washcloth. Dishwasher cleaning is not recommended.

## Convection Microwave (If Equipped)

The convection microwave bridges the gap between microwaving your food and conventional cooking. Make sure there is sufficient 120-volt power before operating the convection microwave (see *Calculating Electrical Load*). For details on operation and safety information, refer to the manufacturer's user guide.

## RANGE HOOD

**⚠ WARNING ⚠** (See page 79)

Your recreational vehicle is equipped with a range hood, it will be connected to an exterior vent.

The vent has an inner flap with two snaps. This flap can be snapped shut when the vehicle is in motion, or during storage to keep insects, debris, snow, rain, etc. from entering the recreational vehicle.

Anytime the stove inside the recreational vehicle is being used, this flap **MUST** be unsnapped and the range hood turned ON to vent fumes outside the vehicle.

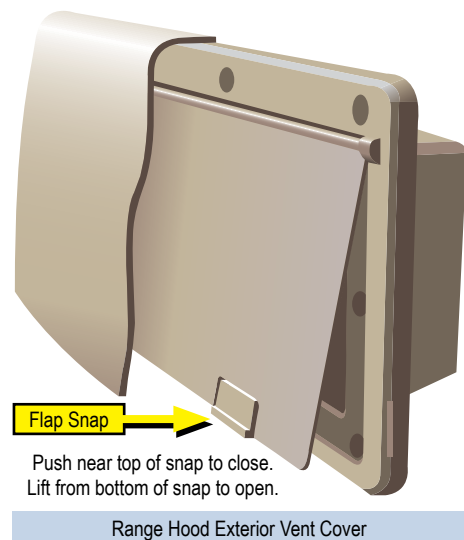

## REFRIGERATOR

**⚠ WARNING ⚠** **⚠ CAUTION ⚠** (See page 79)

The refrigerator is not intended for quick freezing or cooling. We recommend stocking it with pre-frozen or pre-cooled food when possible. The shelves should not be covered with paper or plastic and the food items should be arranged so air can circulate freely. Keep the area at the back of the refrigerator clean and free of debris. Check for obstructions in the exterior refrigerator vent area (i.e., spider webs, bird nests, etc.). Use a soft cloth to dust off the debris. For optimum efficiency and performance, it is recommended the refrigerator be checked at least twice a year as part of the routine maintenance.

For detailed operating and safety information, refer to the manufacturer's user guide.

### Residential Models (if so equipped)

## NOTE

If you are using electric to power the refrigerator, make sure you are connected to a 120-volt power source.

## APPLIANCES

### Cleaning Your Refrigerator

The following are general cleaning guidelines. For detailed information on cleaning your specific refrigerator, refer to the manufacturer's user guide.

#### Cleaning the Interior

1. Unplug refrigerator or disconnect power.
2. Hand wash, rinse, and dry removable parts and interior surfaces thoroughly. Use a clean sponge or soft cloth and a mild detergent in warm water.
3. Inside the refrigerator, use a warm water and baking soda solution consisting of approximately 1-tablespoon (15ml) baking soda to 1 quart (1 liter) of water. This solution cleans and neutralizes odors. Rinse and wipe dry.
4. Leave an open box of baking soda in the refrigerator and freezer to help prevent odors.

## NOTE

Do not use abrasive or harsh cleaners such as window sprays, scouring cleansers, flammable fluids, cleaning waxes, concentrated detergents, bleaches or cleansers containing petroleum products on plastic parts, interior and door liners or gaskets. Do not use paper towels, scouring pads, or other harsh cleaning tools.

There is no need for routine condenser cleaning in normal operating environments. If the environment is particularly greasy or dusty, or if there is significant pet traffic, the condenser should be cleaned every 2 to 3 months to ensure maximum efficiency.

If you need to clean the condenser:

- Remove the base grille.
- Use a vacuum cleaner with a soft brush to clean the grille, the open areas behind the grille and the front surface area of the condenser.
- Replace the base grille when finished.

#### Cleaning the Exterior

**Painted metal exteriors:** wash with a clean sponge or soft cloth and a mild detergent in warm water.

**Stainless steel exteriors:** wash with a clean sponge or soft cloth and a mild detergent in warm water. Do not use appliance wax, polish, bleach, or other products containing chlorine on stainless steel.

Stainless steel can be cleaned with a commercially available stainless steel cleaner. A spray-on stainless steel cleaner works best.

**Do not allow the Stainless Steel Cleaner and Polish to come into contact with any plastic parts such as the trim pieces, dispenser covers or door gaskets. If unintentional contact does occur, clean plastic part with a sponge and mild detergent in warm water. Dry thoroughly with a soft cloth.**

For silver-accented plastic parts, wash with soap or other mild detergents. Wipe clean with a sponge or damp cloth. Do not use scouring pads, powdered cleaners, bleach or cleaners containing bleach as these products can scratch and weaken the paint finish.

### LP GAS GRILL HOOKUP (IF EQUIPPED)

**⚠ WARNING ⚠** **⚠ CAUTION ⚠** (See page 79)

#### Gas BBQ Grill Prep

Your recreation vehicle is equipped with a propane "quick-coupler" connection for easy installation of the BBQ grill.

#### Attaching the "quick coupler" connection

The "quick coupler" is directly connected to the RV propane system. The "quick-coupler" connection is equipped with a positive shut-off valve.

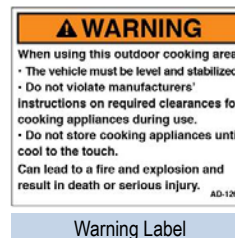

## NOTE

Outdoor cooking warning label should not be removed from the RV.

Place the "quick coupler handle in the OFF position and push back the sleeve. The valve handle must be OFF to make the connection.

1. Insert the plug and release the sleeve.
2. Push the plug until the sleeve snaps forward, locking the plug into the socket.
3. Turn the handle ON to allow propane to flow to the drop in stove.

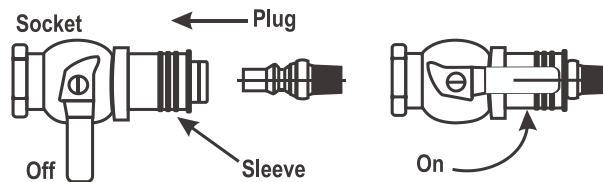

Quick Coupler Connection



## APPLIANCES DANGER

### LP GAS GRILL HOOKUP (See page 78)

Always open the grill lid before turning on gas and lighting burner, failure to open the lid before lighting could cause an explosion causing property damage, injury, or even death.



### **COOKTOPS, RANGE AND OVEN (See page 76)**

- During and after use, do not touch or let clothing or other flammable material come in contact with the top burners or heating elements, burner grates or areas near the top burners or oven until they have had sufficient time to cool. These areas can get hot enough to cause burns.
- Never leave cooking food unattended. Turn pan handles inward, but not over the tops of the other range burners. Ensure that pans used are large enough to contain the food and avoid boil-overs. Heavy splattering or spills left on the cooktop can ignite and cause burns.
- If using glass, glass/ceramic, ceramic, earthenware or other glazed utensils or cookware verify it is safe for use on the top burners.
- **Do not cover the oven vent openings while the oven is in operation.** Restricting the flow of combustion air will create an asphyxiation hazard.

### **REFRIGERATOR (See page 77)**

If you smell propane gas **STOP!** Follow the directions located in your manufacturer's user guide and in this manual.

### **INDUCTION COOKTOP (See page 77)**

Touching a hot pan or cooking vessel can cause burns. Use pot holders or oven mitts to remove hot pans from the cooktop.

### **MICROWAVE (See page 77)**

Never use the microwave cavity for storage. The microwave cavity should always be empty when not in use.

### **RANGE HOOD ((See page 77)**

Whenever the stove in the RV is being used, the Micro Hood ***MUST*** be turned on. **Failure to do so can create an asphyxiation hazard.**

### **IN CASE OF GREASE FIRE ((See page 76)**

Do not attempt to use water to put out the fire. Water can spread some types of fire, and electrocution is possible with an electrical fire.

### **LP GAS GRILL HOOKUP (See page 78)**

- Be sure to read, understand and follow all information supplied with your recreation vehicle concerning the use of propane before operating the BBQ grill. The propane hose must be correctly connected before lighting the grill. Failure to follow instructions supplied by the grill manufacturer, or use of any components other than those originally supplied with the grill, could result in death or serious injury.
- **If you smell gas: Shut off gas to the appliance, extinguish any open flame and open lid. If odor continues, immediately call your gas supplier or your fire department.**
- The BBQ grill is intended for use outside of the recreational vehicle. **Never use a gas grill inside a compartment or inside of the recreational vehicle.**
- The BBQ grill must be **COMPLETELY COOLED** before storing. Storing the BBQ grill before it is completely cool may result in serious injury or property damage.



### **INDUCTION COOKTOP (See page 77)**

Aluminum foil should ***NEVER*** be used with an induction cooktop. It can permanently melt to the cooktop cracking the surface or causing permanent damage.

### **REFRIGERATOR (See page 77)**

The ice maker should be turned off and the ice tray emptied when power to your motorhome has been shut off. With no power, the ice will melt and water will "pool" in the refrigerator door. When power is restored, the vibration will cause this water to run out of the door and on to the motor home floor.

### **MICROWAVE (See page 77)**

- To prevent damage, remove the turntable from the microwave when traveling.
- Make sure you are connected to a 120-volt power source.

### **COOKTOPS, RANGE AND OVEN (See page 76)**

Never use oven cleaners, chlorine bleach, ammonia, or glass cleaners with ammonia. Always allow the cooktop to cool before cleaning.

# SECTION 11: ELECTRONICS



## WINEGARD CONNECT 2.0 (IF EQUIPPED)

The Winegard Connect 2.0 is an integrated system that works together for faster speeds and increased range from Wi-Fi sources. It has the following features:

- Nationwide 4G LTE Coverage - Get Internet while on the go! No need to rely on WiFi – the Connect 2.0 4G2 links to nationwide 4G LTE for reliable, uninterrupted, in-motion and stationary coverage while traveling.
- High-Powered Mobile Internet Hotspot - More powerful than smartphone tethering, the Connect 2.0 4G2 provides a stronger and faster 4G LTE Internet connection. Easily connect your computers, gaming systems, smart TVs, and other smart home devices to secure WiFi in seconds.
- Increased WiFi Range - Winegard's smart antenna technology intelligently manages signals through multiple pathways to ensure better range and performance. The Connect 2.0 4G2 roof-mounted mobile hotspot/WiFi booster allows you to access WiFi signals in your RV from farther away!
- Cellular Data Carrier Options - The Connect 2.0 4G2 is compatible with Winegard, AT&T, Verizon, and T-Mobile cellular Internet service providers. Swap SIM cards to add to new or existing data plans from other carriers. The Connect 2.0 4G2 comes ready for use out of the box, preinstalled with a unique Winegard SIM card. If you choose to use your own 4G LTE plan, easily swap out the existing SIM card with an approved SIM card supplied by your cellular provider.

- Secure RV Internet - Advanced WiFi protected access (WPA and WPA2-PSK), guest network access, double firewall protection (SPI and NAT), and Denial-of-Service (DoS) attack prevention.

For operation of the system, turn on the rocker switch to the 'ON' position. It will enable device(s) that you want to connect and scan for wireless networks.

Refer to the manufacturer's user guide for detailed information on set up and using the system.

## EXTERIOR ENTERTAINMENT CENTER (IF EQUIPPED)

The exterior entertainment center is located on the curbside of the unit. You can access the entertainment center by opening the exterior cargo door to the stationary open position.

Refer to the individual component manufacturer's information for detailed operating instructions.

# SECTION 12: INTERIOR

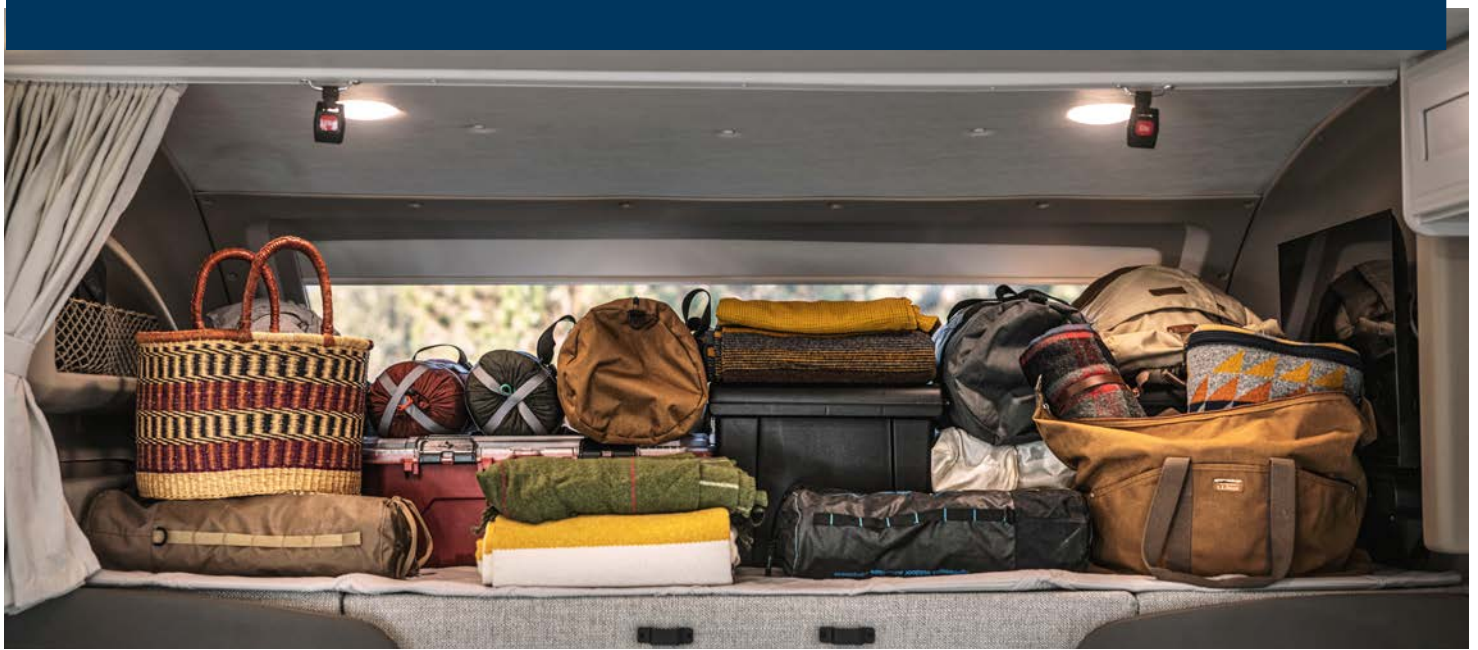

## CLEANING THE INTERIOR

To keep the value of your recreation vehicle, perform regular maintenance using the proper materials and procedures. Using the wrong cleaner may result in damage to the surfaces in your vehicle. Check with the manufacturer's information for the recommended cleaning agent. If in doubt, check to see if the cleaner will cause damage by testing a small area out of sight or contact your dealer for assistance. Do not use flammable liquids or sprays to clean the recreation vehicle.

**Décor Glass (if so equipped):** Use a glass cleaner to remove smudges, smears and spots. If there is decorative etching on the décor glass, use care when cleaning around that area.

**Furniture Upholstery:** Vacuum the furniture upholstery regularly using a soft brush attachment to remove any loose dirt or debris.

**Fabric (if so equipped):** It is recommended the fabric be professionally cleaned if it becomes stained or soiled. The professional cleaner should be made aware the fabrics that may have been treated to be fire resistant. For more information, refer to the specific furniture manufacturer's care instructions.

**Ultraleather™ (if so equipped):** It is recommended the Ultraleather™ be professionally cleaned if it becomes stained or soiled. For more information, refer to the specific furniture manufacturer's care instructions.

**Leather (if so equipped):** Periodic vacuuming, using a dry cloth to wipe up spills immediately, and using a damp cloth on problem areas, will help to keep your leather furniture in good condition. Leather surfaces can vary, as do the cleaning methods. Refer to the furniture manufacturer's recommendation, or consult a cleaning professional.

It is recommended you do not use any cleaners containing oils, waxes or silicones. Cleaners containing silicone can eventually destroy the finish on the leather. Cleaners containing oils or waxes should not be used as they leave residues on the surface of the leather, which can attract more dirt and eventually lead to cracking.

## Window Treatments

**Fabric – Drapes and Valances:** Dust occasionally with a vacuum and soft brush attachment. It is recommended the fabric be professionally cleaned if it becomes stained or soiled. The professional cleaner should be made aware the fabrics that may have been treated to be fire resistant.

## Window Shades

Shades should be vacuumed periodically to remove dust. Using your vacuum cleaner's upholstery brush on low suction will remove most dust and dirt from the shade. Refer to the shade manufacturer's owner's manual for additional and detailed information.

To remove stuck on dust or stains refer to the following guide.

**Solar Shields:** Use a sponge or soft brush and water to remove stains. A mild cleaning solution can be used to remove tougher stains. Rinse after cleaning by wetting a clean cloth in fresh water, wringing out any excess and wiping the areas where the cleaner was used.

**Day/Night Shades:** Clean with a mild cleaning solution using a sponge or paper towel. Wipe down with water after cleaning and dry thoroughly before raising the shade. Do not use spot remover, household cleaners or detergents to remove soiled spots, as these may cause damage to fabric or loss of color from fading.

**Mini Blinds:** A simple dry rag may do the trick. If they are especially dirty, you can use cold or warm water to clean them; **never use hot water.**

Fill a spray bottle with water and a tiny amount of soap. Then spray a lint-free towel with the mixture and use the towel to wipe down each slat. While cleaning, try not to bend the slats. They can also be soaked in a bathtub to loosen up any debris so the slats can be wiped down easily.

**Roller Shades:** Clean by using soapy water or a mild cleaning solution on spots. Try a small area first because harsh household cleaners or detergents may cause damage to fabric or loss of color. It is recommended to dust the rails and fabrics of the shades on a

## INTERIOR

regular basis. Shades should be kept in the closed or up position when not in use to maintain pleat retention and minimize dirt and soil build-up.

### NOTE

If your recreation vehicle must be stored for an extended period, store shades in the up position and cover your windows with additional protection (I.E. cut out cardboard).

### Cabinetry and Tables

To keep hardwood doors, cabinet fronts and hardwood tables looking like new regularly dust with a soft cloth dampened with a cleaning polish or mild detergent solution. Avoid using ammonia based products or silicone oils as they may cause damage if used over a long period of time.

The finish is durable and resistant to most household spills. However, spills should be wiped up promptly to avoid potential problems. Excessive prolonged exposure to direct sunlight, high temperatures and high humidity can cause damage to both the finish and the wood itself.

### Interior Wall Panel

**CAUTION** (See page 85)

To clean, use a mild solution of soap and lukewarm water with a soft sponge or cloth. Wipe dry with a soft, clean cloth.

Putty sticks can be used to cover scratches on the wood surface wall panels. These can be obtained from local hardwood stores and lumberyards. Contact your dealership service department for assistance in repairing décor paneling.

### ABS Plastics

Dust and wipe clean with soft, damp cloth or chamois, wiping gently. Do not use gritty or abrasive particle soaps or scouring compound to clean ABS plastic. Avoid using "citrus" or biodegradable cleaners that contain "D-Limonene" as they may damage plastic materials.

### SOFA AND DINETTE

**WARNING** (See page 85)

Your RV may be equipped with one of the following sofa styles.

#### Hide-a-Bed Sofa or Sofa Sleeper

To make the hide-a-bed sofa into a bed, remove the seat cushions and pull the strap located at the front of the sofa seat bottom out towards you firmly and gently. To convert the hide-a-bed back into the upright sofa position, reverse the process (make sure to pull the seat belts out into their usable positions). Be sure to hold the sofa strap firmly to ensure the hide-a-bed sofa does not suddenly drop shut. Refer to the furniture manufacturer's care instructions for this product.

#### Jack Knife or Easy Bed Sofa

The easy bed sofa should comfortably seat two to three adults. It converts to a bed by lifting at the front of the sofa seat section and pulling it towards you. The sofa back will follow and pivot down into a horizontal position. To reconvert back to an upright sofa, reverse the process (make sure to pull the seat belts out into their usable positions). Refer to the furniture manufacturer's care instructions for this product.

#### Trifold Sofa

The trifold sofa offers very similar features to a traditional hide-a-bed. The following illustrations detail converting the sofa into a bed.

1. Remove the tri-fold sofa pillows and set aside.
2. Using the strap handle, pull the sleeping surface up, then out.
3. While sleeping surface is up, fold out legs. Extend the sleeping surface until grounded.
4. Once sleeping surface is grounded, fold head board down flat.



#### Dinette Table

Depending on your model, the dinette table can be extended by standing at the end of the table, firmly holding both sides of the table, and pulling the table towards you. To return the table to the stowed position, reverse this process pushing it in until the table locks in place.

#### Booth Dinette (if so equipped)

The booth dinette can be converted to a bed by lowering the tabletop to make the bed base.

#### To convert dinette to a bed:

1. Remove the cushions from the dinette.
2. Grasp the table top at the rounded end, and lift the rounded end up at an angle (A).
3. The table top will separate from the bracket attached to the wall.
4. Pull the table top away from the wall, toward you slightly.
5. Lower the table top down between the seats (B).
6. Place the extra cushion on the table top between the 2 seats.
7. Replace the seat cushions.

#### To convert back to a table:

1. Remove cushions.
2. Lift table top back up to the bracket.
3. Hold the table top at an angle (A).
4. Push the table top back toward the wall.
5. Bracket should latch, put the table top to a level position.

## Free Standing Dinette Chairs (if so equipped)

**⚠ WARNING ⚠** (See page 85)

Two free standing chairs and two folding chairs are included in the free standing table/chair package. When traveling in the motor home, the free standing chairs should be fastened securely at the dinette table, and the folding chairs be secured in a closet or storage area.

## COUNTERTOPS

### To prevent permanent damage

- Always use hot pads or trivets under hot pans, dishes, or heat producing appliances.
- Heat will damage countertops.
- Use a cutting board to prevent unnecessary damage to the countertops. Do not cut directly on the countertop.
- Avoid harsh chemicals such as drain cleaners, oven cleaners, etc.
- Do not let cleaners with bleach set on the top. Wipe them off promptly.
- Run cold water when pouring hot/boiling water into the sink.
- Use coasters under all glasses, bottles and cans.
- Do not store toiletry products directly on your countertop surface. Hair products, perfumes, colognes, nail products, creams, lotions and potions have a tendency to spill or leak and go overlooked. Even though the counter top is sealed, a substance that remains on the surface for an extended period may stain the countertop.

For additional information on the removal of difficult stains or surface damage repair, refer to the countertop manufacturer's user guide.

### Solid Surface Countertops

Soapy water, ammonia based cleaners (not window cleaners as they can leave a waxy build up that may dull the surface) or commercially available solid surface cleaners will remove most dirt and residue from all types of finishes. A damp cloth followed by a dry towel will remove watermarks.

Difficult stains can be removed from the matte finish with a green Scotch Brite® pad and a mild abrasive cleaner. Disinfect the surface periodically with diluted household bleach (one part water to one part bleach).

For cuts and scratches, sand the matte finish lightly with (220) fine grit sandpaper until the cut or scratch is gone. Restore finish with a green Scotch Brite® pad and mild abrasive cleaner.

### Solid surface sink maintenance

Occasionally, clean the solid surface sink by filling one-quarter full with a 50/50 water/bleach solution. Let soak for 15 minutes, and then wash sides and bottom of sink as solution drains.

### Laminate Countertops

Glass rings, food spills, water spots and smudges usually wipe off with a damp sponge. All stains must be cleaned immediately, especially oil and food splashes. Any mild and non-abrasive household detergent can be used, however micro-fibre cloths are recommended for high-gloss laminates to minimize the risk of scratching the surfaces. Dry all surfaces if it is wet after cleaning.

If a stain persists, use a paste of baking soda and water and apply with a wet sponge. Light scrubbing for 10 to 20 strokes should remove most stains. Although baking soda is a low abrasive, excessive scrubbing or exerting too much force could damage the decorative surface, especially if it has a gloss finish.

## PANTRY OR HUTCH (IF EQUIPPED)

**⚠ WARNING ⚠** (See page 85)

Your recreation vehicle may have a pantry or hutch that you can use for storage. Make sure all items stored in the pantry or hutch are secured to prevent shifting during travel. This cabinetry has been designed to accommodate the normal camping items which may be bulky but not necessarily heavy. **Remember your recreation vehicle's load capacity is designed by weight, not volume, so you cannot necessarily use all available space.**

If your pantry or hutch has sliding pantry shelves, they have been equipped with a locking mechanism to keep them in place during transit. To secure the shelf in place, push it all of the way in until the latch tab clicks into place. Always pull out slightly on the shelf to make sure that it is stationary and secure in the transit position. To release the shelf, push in on the tab and pull the shelf slowly towards you.

## FLOORING

### Vinyl Flooring (if equipped)

Periodically vacuum or sweep to remove dirt and gritty particles. Although most common spills will not permanently stain the vinyl floors, they are usually easier to remove if wiped up before they set. Blot with a paper towel and wipe clean with a damp cloth. Do not use dish detergents or vinegar and water because they will dull your floor.

To care for the vinyl floor covering, use a damp mop with water and a mild cleaner on the entire floor. **DO NOT SOAK THE FLOORING.** Use care to avoid wetting the carpet edges. To avoid problems of "yellowing" linoleum, the flooring manufacturer recommends avoiding cleaners that contain oil based solvents (i.e. lemon oil, Murphy's Oil Soap, etc.).

### CEILING FABRIC

The ceiling fabric is made from padded vinyl fabric. Wash with mild detergent and water. Use a soft bristle brush for stubborn soil. Rinse and dry. Some household cleaners and solvents remove plasticizers from vinyl, making them brittle. Abrasive cleaners may mar or scratch the surface. Always test a small hidden area before applying cleaners to the vinyl surface.

## BED STORAGE

**⚠ WARNING ⚠** (See page 85)

Additional storage has been provided under the bed. To access the storage area, grasp the ledge at the foot of the bed and lift carefully. ***The bed platform must be held when raised.***

***It is recommended that two people retrieve stored items from under the bed*** so that one person may hold the platform, and the other can retrieve the stored items from under the bed. Lower the platform slowly to close it. **DO NOT DROP THE PLATFORM.**

Some models may be equipped with a **prop rod** to assist with easy access to under bed storage.

## INTERIOR

**Prop Rod:** If your model is equipped with a prop rod:

- With the help of a second person, raise the bed platform.
- Release the prop rod from its holder.
- Put the end of the rod in the bracket under the bed platform.
- To lower the platform, release the prop rod from the bracket under the bed platform, re-attach the prop rod to the holder on the bed base.
- Lower the platform slowly until closed.



## BUNK BEDS AND BUNK LADDERS (IF EQUIPPED)

**⚠ WARNING ⚠** (See page 85)

Your recreational vehicle may be equipped with bunk style beds. Bunk bed weight ratings may vary depending on your model and the style of bunk bed. Weight capacities are listed on the bunk capacity label. Do not exceed the bunk weight capacity.

### Cab-Over Bunk Bed

Your motor home may be equipped with an over-the-cab bunk bed. This bunk bed is accessed through the use of a steel ladder that hooks to the bed platform.

### Bunk Ladders (if so equipped)

Your recreational vehicle may be equipped with a ladder to access the upper bunk. This ladder may be a separate steel ladder, or a wooden ladder attached to the bunk beds.

The top of the ladder is secured to the ladder storage compartment. To operate the ladder, lift up and out of the storage tray. Pivot the bottom of the ladder out. Be sure the ladder is securely in place on the floor before climbing to the upper bunk.

When storing the wood ladder, place the bottom of the ladder back into the tray in the storage compartment. This keeps it secure during transport and clear of walkways.

The steel ladder (if equipped) will simply hook onto the upper bunk.



## PRIVACY DRAPE INSTALLATION

1. Starting on the driver's side, attach the black plastic hook to the loop on the wall (behind the driver's seat). Make sure the Velcro® on the drape is facing the motor home windshield.
2. Pull the drape towards the windshield and past the driver's side sun visor. Open the sun visor against the windshield to hold the drape in place.
3. Continue across the windshield to the passenger side, again opening the sun visor and placing the drape behind it.
4. Attach the black plastic hook on the passenger side of the drape, to the loop on the wall behind the passenger's seat.
5. Attach the Velcro® at the top edge of the drape to the corresponding Velcro® on the cab area roof (above the driver's and passenger's doors).
6. Attach the Velcro® at the bottom corners of the drape to the corresponding Velcro® on the wall.

## NOTE

Some types of bunk beds do not include a ladder.

 **WARNING** 

**BUNK BEDS AND BUNK LADDERS (See page 84)**

- Exercise extreme care when entering or exiting the bunk beds and using the ladder.
- Do not allow more than one person on the top bunk.
- Do not allow children under 6 years of age to use the upper bunk.
- Do not allow horseplay on or under the bed and prohibit jumping on the bed.
- Make sure the ladder is anchored properly to the bed.
- Never allow more than one person on the ladder at a time.
- Children should always be supervised when using the ladder or when entering or exiting the bunk beds.
- Weight limit of the bunk ladder is 300 lbs. (136 kg). Never exceed this weight.
- Maximum weight limits for bunk beds will vary depending on model or bunk style. **Never exceed the maximum weight specified on the bunk capacity label.**
- Failure to follow these instructions can result in serious bodily injury.

**BED STORAGE (See page 83)**

- Before lifting, be sure there is nothing on the bed that will restrict its movement or add extra weight.
- **Use caution when opening or closing the bed to keep hands and fingers at the end ledge provided (not on the side or farther back than necessary).**
- Exercise extreme caution when opening the bed storage platform. Platform must be held open (unless equipped with a prop rod or gas struts) and slowly lowered until closed.
- The bedroom electric slide room system may be located under the bed. Use care not to obstruct the slide room system when using the under bed storage.
- **Failure to comply with these guidelines can result in serious injury or property damage.**

**FREE STANDING DINETTE CHAIRS (See page 83)**

Do not allow occupants to occupy the free standing dinette chairs while the motor home is in transit.

**SOFA AND DINETTE (See page 82)**

Always use seatbelts if sitting in the sofa or dinette while the motor home is in transit.

**PANTRY OR HUTCH (See page 83)**

Your RV's load capacity is designated by weight, not by volume, so you cannot necessarily use all available space when loading the vehicle. Do not exceed your GVWR and ensure you are loading the vehicle as evenly as you can for the best possible handling. Ensure heavy items are secured so they do not shift during travel.

 **CAUTION** 

**INTERIOR WALL PANEL (See page 82)**

Do not use abrasive cleaners as they may cause the vinyl to scratch and become dull. Do not use cleaners that contain bleach.

# SECTION 13: EXTERIOR



## CLEANING THE EXTERIOR

To protect your recreation vehicle's exterior finish, wash it often and thoroughly. You may wash and wax your new recreation vehicle 60 days after purchase. The exterior paint needs time to cure before any wax is applied to the exterior surface. Careful maintenance for the first 60 days will assure a long lasting durable finish.

Your RV is exposed to many environmental conditions that have an adverse affect on the paint finish:

- Road Salt and Sodium Chloride
- Road Tar / Bugs
- Bird Droppings / Tree Sap
- Industrial Fallout / Acid Rain/Pollution
- UV Exposure and Moisture

The most common problems resulting from these conditions are corrosion, staining, and chemical spotting. Generally, the longer the foreign material remains in contact with the exterior finish the more extensive the damage. These problems can be minimized by regularly scheduled washing and polishing. Wash your recreation vehicle as soon as possible if it becomes contaminated with foreign material.

Avoid parking under trees or near ocean sea salt. Ice or snow should be brushed off, not scraped, from the painted surface. Avoid gravel roads.

Anti-freeze, gasoline or washer solvents if spilled on the painted surface should be rinsed off with water immediately. Bugs and bird droppings should be rinsed off daily.

## Washing

Commercial washing should be avoided. Wash with cold water using a mild liquid soap. Dry wiping with a dry cloth is not recommended.

Make sure the RV's surface temperature is cool, under 90 F, and out of direct sunlight. A shaded area is ideal for washing your vehicle as direct sunlight causes water spotting. Use a mild soap, detergent or car wash shampoo. Try to avoid combination wash-n-wax products as these waxes can cause build up and are designed for smaller surfaces. Have two dedicated sponges or wash mitts: one for the paint finish and one for the wheels and under carriage. Brushes or wash mitts made of plastic bristles are acceptable for use on tires and wheel wells, but are not intended for use on the paint finish. Avoid using such items on painted surfaces as they will damage the finish. Wash the wheels and wheel wells first as this removes heavy dirt and debris and prevents it from splattering on panels. Wet the entire area down to remove loose dirt and grime, then hand wash one area at a time using your dedicated paint finish sponge or wash mitt. Wash from the top and work your way down, rinsing frequently to minimize grit abrasion. Follow with a final rinse of water. This process will remove most contamination from the RV's surface.

For stubborn stains such as road tar or bug stains, use an ammonia based glass cleaner or a small amount of rubbing alcohol on a damp cloth followed immediately by warm soapy water, and rinse with clean water. This may not dissolve the road tar, but it will loosen tar and bug stains and remove them from the surface.

Do not use solvent based cleaners on bird droppings or tree sap as these are water based stains. They can be dissolved using ammonia based glass cleaner, warm soapy water and a little "elbow grease". After removing stubborn stains immediately rinse with clean water.

Drying the RV is just as important as washing it. Tap water and well water contain many chemicals that could water stain your RV's finish.

We suggest using a damp natural or synthetic chamois. Other drying products such as lint-free micro-fiber towels that work just as well.

### During cold weather

Salt and other chemicals that are spread on winter roads in some geographical areas can have a detrimental effect on the recreation vehicle's underbody.

**If your recreation vehicle is exposed to these conditions, spray the underbody with a high-pressure hose every time you wash the exterior of your recreation vehicle.**

Take special care to remove mud or other debris that could trap and hold salt or moisture. After washing your recreation vehicle, wipe off all water drops from the rubber parts around the slideout and doors.

## NOTE

When the slideout or door is frozen, opening it by force may tear off or crack the rubber gasket that is installed around the slideout or door. Pour warm water on the gasket to melt the ice (wipe off the water thoroughly after opening the slideout or door). To prevent the weather stripping from freezing, treat it with a silicone spray.

### Waxing

**CAUTION** (See (See page 89))

Wax your recreation vehicle once or twice a year, or when painted surfaces do not shed water well. Use a soft cloth to apply a small amount of wax to the painted surfaces. After the wax has dried, polish the recreation vehicle with a dry, soft cloth.

Do not wax your recreation vehicle in direct sunlight. Wax it after the surfaces have cooled. Do not apply wax to any area having a flat black finish as it can cause discoloration. If the finish has been stained with wax, wipe off the area with a soft cloth and warm water. When waxing the area around the various openings, do not apply any wax on the weather strip. If it is stained with wax, the weather strip cannot maintain a weatherproof seal around the opening.

### Polishing your recreation vehicle

If painted surfaces have been severely damaged and have lost their original luster and color tone, polish the surface lightly with a fine polishing compound. Avoid limiting your polishing to the damaged surface only; polish a somewhat wider area, moving the polishing cloth in one direction. After polishing, flush the compound from the surface and apply a coat of wax to regain a beautiful luster.

### Damaged paint

To prevent corrosion, touch up small cracks and scratches in the paint coat as soon as possible with touch-up film or paint. Carefully check the body areas facing the road and the tires for damage to the paint coat caused by flying stones, etc.

### Cleaning plastic parts

**CAUTION** (See (See page 89))

Use a sponge or chamois to clean plastic parts. Use warm water and a soft cloth or chamois to remove any white residue from dark colored plastic surfaces. Do not use a scrubbing brush, other hard tools, or wax containing abrasives as they may damage the plastic surface.

### Chrome parts

To prevent chrome parts from spotting or corroding, wash with water, dry thoroughly, and apply a non-abrasive automotive wax. If the chrome is severely damaged or pitted, use a commercially available chrome polish product.

## CLEANING THE DIAMOND SHIELD SURFACE

Your motor home is equipped with a protective Diamond Shield surface located on the front lower cap area, hood edges, generator door, under the entry door grab handle and door lock. When cleaning the surface, do not use harsh or abrasive cleaners or detergents. The manufacturer of the Diamond Shield surface does not recommend the use of any of the dry wash types of cleaners as they are intended for non-porous surfaces, and paint protection films are a porous material. Car wash type soap is recommended.

Bugs should be washed off as soon as possible. One bug cleaner recommended by Diamond Shield is Bug Magic.

Use EXTREME care if using a pressure washer, as too high of a pressure or misuse of pressure washer may cut or tear the film. Pressure washer damage IS NOT covered under Diamond Shield's warranty. The application of ANY products over Diamond Shield such as vinyl bras, banners, etc. will void the Diamond Shield warranty.

Diamond Shield recommends the use of 303 Aerospace Protectant™ or Protect All [www.protectall.com](http://www.protectall.com) especially before any trips. Both of these products replenish and provide UV screening protection, repel dust, soiling and staining, and should be applied every time you clean the front of your motor home. For minor scuffs Diamond Shield recommends the NOVUS line of products. Diamond Shield recommends Mothers or Maguire's Liquid wax. DO NOT USE wax designed for specific colors. It is recommended to wax the Diamond Shield surface at least 3-4 times per year and prior to putting your motor home into storage.

## NOTE

The use of a protective covering (bra) is not recommended and will void the limited lifetime warranty of the diamond shield protective surface.

### FRAME

Frames receive heavy abuse from road conditions such as sand, pebbles, objects in the highway, and/or ice inhibiting chemicals, all of which will cause chipping and a blasting effect on the painted surface. Frames will show signs of rust much sooner when exposed to salty air. Periodically rinse off the frame (or as use requires) removing road grime, tar, oil, mud or salt.

Refer to your Chassis Guide for the chassis manufacturer's maintenance instructions.

### MUD FLAP

**CAUTION** (See (See page 89))

Your motor home is equipped with rear wheel mud flaps and/or a deluxe full-width mud flap, periodically check and remove dirt or debris buildup from the mud flaps.

## EXTERIOR

### EXTERIOR LADDER (IF EQUIPPED)

**⚠ WARNING ⚠** (See (See page 89))

Your recreation vehicle may be equipped with an exterior roof ladder. The RV roof construction allows you to walk on the roof (with caution) to do maintenance.

### EXTERIOR ROOF AND SIDEWALL VENTS

Inspect the roof vents, including sealants for cracks and keep them clean. Inspect the refrigerator and holding tank vents for blockages from bird nests, spider webs, leaves, etc. All exterior access doors and vents need to be kept clean and free of obstructions (i.e., insect nests, mud daubers, etc.) while the appliances are in use.

### WINDOWS

**⚠ WARNING ⚠** (See (See page 89))

Any ventilating window may permit water inside, especially during heavy rainstorms or while driving. This is normal and water should only be seen in the lower track portion of the window frame. Condensation will also cause water to accumulate on windows and in the tracks. Ensure that the escape window latches are properly adjusted (the window will pop open if not adjusted tight enough).

#### Window glass

The window glass can normally be cleaned with a sponge and water. Use glass cleaner to remove wax, oil, grease, dead insects, etc. After washing the glass, wipe it dry with a clean, soft cloth.

### SEALANTS

**⚠ CAUTION ⚠** (See (See page 89))

Sealants perform a very important function and should be inspected closely and regularly maintained. We incorporate many different types of sealants, including butyl/putty, black butyl-encapsulated foam, silicone (clear and colored), roof sealant and foam. In general, sealants do not have "set" lifetimes. Varying environmental factors affect the pliability and adhesiveness of sealants.

#### You or your dealer must:

- Inspect all sealants, a minimum of every six months. Make sure to check the roof and all four sides of the recreation vehicle including all moldings, doors, vents and exterior attachments. A quick walk around the recreation vehicle before leaving may help prevent potential problems during trips and vacations.
- Have the sealant replaced if you notice any cracks, peeling, voids, gaps, breaks, looseness or any sign of physical deterioration. Reseal at least one time each year as preventative maintenance.
- Always use the same type of sealant that was removed. Your dealer service or parts manager can help you obtain the correct sealant(s).

The sealants may become damaged due to road vibration, ultraviolet exposure, air pollution, freezing temperatures and exposure to other elements. Repair deteriorated sealants immediately to prevent damage. Cap seal all trim and openings at least once after the first year and thereafter as cracks, peeling, lifting and shrinkage occur.

If you notice water inside the recreation vehicle, immediately have the dealer check for the source of the leak. Failure to correct the leak may result in serious damage to your recreation vehicle, and this damage may not be warrantable.

If you have questions and/or need assistance with sealing your recreation vehicle, consult with your recreation vehicle dealer.

**WINDOWS (See page 88)**

To avoid exhaust gas entry into the motor home, keep windows closed when the chassis or generator engines are running.

**EXTERIOR LADDER (See page 88)**

- Do not leave items attached to the ladder while traveling. DO NOT exceed the weight rating of the ladder. The ladder weight capacity label is located under the bottom step of the ladder. There should never be more than one person on the ladder at the same time.

**LADDER CAPACITY MAXIMUM 300 lbs. (136 kg)**

- **DO NOT** exceed the ladder maximum weight rating.
- The maximum rating includes the person's weight **PLUS** weight of items carried.
- When climbing:
  - » Always face the ladder.
  - » Climb slowly with weight centered between side rails.
  - » Keep a 3 point contact on the ladder at all times (3 Point contact-two hands and a foot or two feet and one hand).
- Keep hands free.
  - » Use of accessories such as lanyards to keep carried items tethered will keep hands free and prevent falling items.
  - » Heavy or bulky items should be brought up only after reaching the roof.
- Do not use the ladder if damaged in any way.

Failure to follow these guidelines could result in death or serious injury.

**WAXING ((See page 87))**

- Do not use waxes containing high-abrasive compounds. Such waxes remove rust and stains effectively from the paint work, but they are also harmful to the luster of the painted surface since they scrape off the coating. Further, they are detrimental to glossy surfaces, such as the grille, garnish, moldings, etc. Do not use gasoline or paint thinners to remove road tar or other contamination to the painted surface.
- Do not use a buffer and a buffing compound as it may damage the exterior surface. Please contact a professional paint body shop for assistance.

**CLEANING PLASTIC PARTS ((See page 87))**

Do not allow plastic to come into contact with brake fluid, engine oil, grease, paint thinner, or battery acid. These will damage plastic. Use a soft cloth and a mild detergent solution to wipe away any such contact.

**SEALANTS ((See page 88))**

- Failure to properly maintain or reseal your recreation vehicle may result in serious water damage to the roof and other parts of the recreation vehicle. This damage is not covered by the **Limited Warranty**.
- To check the exterior sidewall sealants, use a stepladder placed safely alongside the vehicle. Do not prop a ladder against the body of the RV as it may damage the exterior finish.

**MUD FLAP ((See page 87))**

The mud flap(s) should never be tilted towards the exhaust pipe when the motor home is not in motion or when the motor home is moving in reverse. Caution should be used when parking the motor home to assure the mud flap does not become caught or hung up on stationary items on the ground. This could result in damage to the mud flap(s).

# SECTION 14: CHECKLISTS



## MOTOR HOME STORAGE

Properly preparing your motor home for storage during periods of non-usage will prevent problems from arising. It will also make it easier to get started again for the following camping trip or season. To prevent costly freeze-ups, winterize the plumbing system when it will not be in use for an extended period of time, especially if it is stored in colder climates.

### Prior to storage:

- Prepare the chassis for storage in accordance to the Chassis Guide. Remember to use fuel additives and supplements if recommended.
- Wash and wax the exterior of the vehicle. Do a sealant inspection and repair as necessary.
- Inspect and clean tires. Check for wear, cracks and inflation pressure.
- Inspect and seal off any area that offers an entry point for rodents, birds or insects. Cover all external outlets (i.e. furnace, vents etc.). Damage from birds, rodents, insect, etc., is not covered under the “Motorized Transferable Limited Warranty” applicable to your motor home.
- Close all windows, roof vents and range hood vent.
- Turn the furnace thermostat(s) to the OFF position (if equipped).
- If your motor home is equipped with a gas/electric DSI range, light a range gas burner to consume any gas remaining in the lines. Once the flame extinguishes itself, turn the burner valve OFF.

- Drain all water lines. Make sure the motor home is winterized.
- Winterize the toilet and appliances (dishwasher, refrigerator, clothes washer).
- Drain and flush all holding tanks (fresh water, gray water, black water and/or hot water tanks).
- Adding fuel stabilizer to the generator will aid in preventing condensation and fuel varnishing.
- Turn OFF the motor home 12-volt battery disconnect switch.
- Turn OFF the inverter mode at remote.
- Disconnect the batteries to prevent battery discharge.
- Remove all perishables from the refrigerator/freezer. Defrost, wash and dry the interior of the refrigerator/freezer and prop (or block) the doors open so air can circulate and prevent mildew.
- Remove all perishables from the cabinets. Leave the cabinets and doors ajar to allow air circulation and prevent mildew and musty odors.
- Lubricate locks and hinges on exterior doors.

### While the motor home is being stored

If the vehicle is stored outside in areas of heavy snow, you should periodically brush the snow off to prevent excessive accumulation and prevent possible roof damage.

# CHECKLISTS

## TRAVEL CHECKLIST

Following is a preliminary list of items that need to be checked before leaving your home or campsite. This is a general list, which you may want to customize as you determine your own needs. Refer to your Chassis Guide for information on chassis pre-trip inspections and maintenance.

### Safety

- Make sure you follow all safety precautions noted in this owner's manual and in any manufacturer's operators manual when preparing to travel.

### Before leaving home:

- Make sure all fluids are at proper levels (engine oil, transmission fluid, engine coolant, power steering fluid and windshield washer fluid).
- Check the fuel gauge and lights on the motor home. **Have someone observe the operation of all exterior lights while you activate the controls. Check the turn signal and high beam indicators on the instrument panel.**
- Examine the tires for excessive tread wear or uneven wear patterns. Check for stones, nails, glass or other objects lodged in the tread. Inspect for tread cuts or sidewall cracks.
- **Check tire pressure and correct according to manufacturer specifications.**
- **Check wheel nuts for tightness.**
- Inspect and work all interior and exterior latches and locks and lube if necessary.
- Make sure the batteries are fully charged and installed correctly.
- Turn ON the motor home 12-volt battery disconnect switch.
- Inspect the power cord and carefully clean the contacts if necessary. Plug in the power cord to an appropriate power source.
- Turn on the interior lights and check outlets for polarity. If needed, replace any blown fuses. Check the circuit breakers and test the GFCI circuits.
- **Inspect and turn on the propane gas system** (if equipped). If you have any questions, contact your independent dealer or a qualified propane gas service representative for assistance. If the propane system is functioning properly, test any pilot lights or direct spark ignition features. Turn off the propane when finished.
- **Inspect and test all safety detectors.** If needed, replace any drained or discharged batteries. If you have a defective or damaged safety detector, replace it immediately.

- Inspect the leveling jacks for operation. If needed, perform maintenance as per the manufacturer's information.
- Test all exterior and interior lights. Replace any bulbs that are burnt out.
- **Prepare the chassis portion of the motor home for the camping season in accordance with the Chassis Guide.**
- Wash the exterior of the motor home. Do a sealant inspection and repair as necessary.
- De-winterize and sanitize system.
- **If you are towing a vehicle, connect it to the motor home and test all connections and lights (if applicable).**
- **Test brakes for proper operation.**
- Fill the fresh water tank. Disconnect, drain and store the garden hose on the bracket.
- **Check the seat belt buckles and release mechanisms for positive action and secure connections.**

### Before leaving the campsite:

- Check the area under the motor home after overnight parking and look for fuel, water, oil or other fluid leaks. If leaks are detected, find the cause and correct it immediately.
- Turn off propane tanks (if so equipped).
- Empty black and gray holding tank, rinse as needed.
- Retract any awnings and secure them for transport.
- Close all the roof vents.
- Close windows and latch blinds.
- Disconnect the cable TV and phone hookups and lower the TV antenna.
- Turn off the interior lights, water heater, furnace and water pump.
- Secure any loose, heavy or sharp objects in the motor home or exterior compartments.
- Disconnect the power cord and ensure it is stored correctly.
- Disconnect any water connections.
- Water pump and water heater (if applicable) turned off.
- Fasten all interior and exterior doors securely; lock them (if applicable). Latch drawers, cabinets and doors.
- Move slideout(s) in and lock it in place (if applicable).
- Walk around your motor home one last time to make sure everything is stored away and the baggage compartments are closed and locked.
- Refrigerator door locked.
- Furnace turned off.
- Make sure the leveling jacks are retracted to the travel position.
- Retract step.
- Secure and lock the entrance door.



# SECTION 15: ADDITIONAL INFORMATION



## HELPFUL LINKS

Disclaimer: These links are being provided as a convenience and for informational purposes only; they do not constitute an endorsement by Entegra Coach, Inc. or any of its subsidiaries regarding any of the products, services, or opinions contained within. Entegra Coach, Inc. bears no responsibility for the accuracy, legality or content of the external site or for that of subsequent links. Contact the external site for answers to questions regarding its content.

## CLUBS & ORGANIZATIONS

### FMCA

[fmca.com](http://fmca.com)

The FMCA educates, equips, and empowers RV owners in their journey to creating, experiencing, and benefiting from the outdoor lifestyle they dream of and deserve. All motorized and towable RVs welcome.



### Good Sam Club

[goodsam.com](http://goodsam.com)

Part of the RV community since 1966, Good Sam was founded on the idea of being good, doing good, and helping others. With over 2 million Good Sam Members and over 2100 Good Sam Parks and campgrounds, Good Sam makes it easy to travel and connect. Good Sam also offers a full suite of protection products including insurance, roadside assistance, extended service plans, and more.



### Harvest Hosts

[harvesthosts.com](http://harvesthosts.com)

Harvest Hosts is an RV membership program that provides unlimited overnight stays at thousands of locations nationwide such as farms, breweries, wineries, and much more. New members save 20% off of their first year of membership with the code JAYCO20.



### Passport America

[passportamerica.com](http://passportamerica.com)

Passport America is a discount membership club that provides half price camping to a network of Over 1,200+ quality campgrounds and RV parks throughout the U.S., Canada and Mexico.



## TRAVEL RESOURCES

### Bring Fido

[bringfido.com](http://bringfido.com)



Explore over 500,000 places to stay, play, and eat with your dog.

### U.S. Dept. of Transportation

[fhwa.dot.gov/trafficinfo/index.htm](http://fhwa.dot.gov/trafficinfo/index.htm)

Federal Highway Administration's National Traffic and Road Closure Information



### National Weather Service

[weather.gov/alerts](http://weather.gov/alerts)

National Weather Service Weather Alerts



### Roadtrippers

[roadtrippers.com](http://roadtrippers.com)



Plan your next road trip route with Roadtrippers. Enter where you want to start and finish your road trip, and then discover the coolest "off the beaten path" places along the way.

Included in "Roadpass Pro".

### Sanidumps

[sanidumps.com](http://sanidumps.com)

Sanidumps is a comprehensive RV dump station search site.



### Togo RV

[togorv.com](http://togorv.com)



Features and benefits include RV-specific GPS navigation, high-value member discounts, access to free boondocking locations, service and maintenance schedule tracking, customizable checklists, RV Living stories, and a mobile repair locator.

Included in "Roadpass Pro".

## ADDITIONAL INFORMATION

### CAMPSITE LOCATORS

#### Go Camping America

[gocampingamerica.com](http://gocampingamerica.com)

Whether you're planning the cross-country trip of a lifetime or just a weekend getaway, GoCampingAmerica.com is the best way to find the perfect home away from home for your next adventure.



#### AllStays

[allstays.com](http://allstays.com)

AllStays has comprehensive lists, maps, apps, and search tools for over 37,000 campsites.



#### National Park Service - Find a Park

[nps.gov/findapark](http://nps.gov/findapark)

The National Park Service website is a great resource for information on the national parks across the country. From there you can find a park, research events, and discover trip ideas.



#### Campendium

[campendium.com](http://campendium.com)

Campendium lists tens of thousands of places to camp, vetted by their team, and reviewed by over 750,000+ members.

Included in "Roadpass Pro".



#### RV Life Campground Reviews

[campgrounds.rvlife.com](http://campgrounds.rvlife.com)

RV Life Campground Reviews will help you find a campground with easy to use maps and visitor reviews.



#### USCampgrounds.info

[uscampgrounds.info](http://uscampgrounds.info)

Web listing of over 13,000 public campgrounds in the US and Canada that are vehicle-accessible, family campgrounds with 4 or more campsites.



### NEWS & STORIES

#### Go RVing

[gorving.com](http://gorving.com)



The Go RVing program is the consumer-facing voice of the RV industry with a mission to inspire potential RVers, spark curiosity, and raise awareness about the benefits and accessibility of RVing through rich, authentic, and diverse storytelling.

### OTHER INFORMATION

#### Neighbor

[neighbor.com/rv-storage-near-me](http://neighbor.com/rv-storage-near-me)



Get out and use your RV more, store it with a neighbor. Find a spot on Neighbor.com—the world's largest RV storage & self-storage marketplace. Find space in your neighborhood today, it's closer, safer, and cheaper than traditional RV storage. Neighbor.com, like it never left home.

#### RVIA

[rvia.org](http://rvia.org)

RV Industry Association is the leading trade voice of the RV industry, representing approximately 495 manufacturers and component and aftermarket suppliers who together produce 98 percent of all RVs made in the United States, and approximately 60 percent of RVs produced worldwide.



#### Roadpass Pro

[roadpass.com/pro](http://roadpass.com/pro)



Purchasing a new Jayco Family RV makes you eligible for one FREE year of Roadpass Pro, which includes bonus features to the apps "Campendium", "Roadtrippers", and "Togo RV".

Visit [roadpass.com/first](http://roadpass.com/first) to sign up.

Current owners can receive a 30% discount on Roadpass Pro using the discount code below for your RV.

- Jayco Family: JAYCOFAMILY68

